

USER MANUAL

Admiral 36

Rider Scrubber



PowerBoss, Inc.
A Member Of The Hako Group

Table of contents

Proper use	3	Brushes/Pads	21
Acceptance of the machine	3	Installation of brushes/drive plate ...	22
General safety instructions.....	4	Removal of brushes/drive plate	22
Method of operation		Soiled and fresh water tanks.....	23
of Admiral 36.....	6	Removal of filter	23
		Installation/Removal of squeegee ...	24
How to take the machine		Electrical system	24
into operation	6	Towing	24
Assembly	6		
Battery systems.....	7	Technical data.....	25
Battery charge warning unit	7	Battery systems.....	27
Charger units	7	Noise level	27
Installation of battery	8	Vibrations.....	27
Plug connection coding	9	Maintenance work.....	28
		Service display	29
Operation/Operation elements	11	Maintenance work	30
Driving with the Admiral 36.....	12		
Working with the Admiral 36.....	18		
Detergents	18		
Refilling the fresh water tank.....	18		

Please be advised explicitly that we cannot accept any legal claims out of the contents of this manual.

If repair work has to be performed, make sure that only genuine spare parts may guarantee a dependable machine and will make sure that your rights under current warranty are not affected.

We reserve the right for technical improvements

Valid as of: May 2007

PowerBoss Inc.
 175 Anderson Street
 Aberdeen, NC 28315 U.S.A.
 Telephone (910) 944-2105
 Fax: (910) 944-740

It is our desire that the excellent properties of the Admiral 36 should justify the confidence you demonstrated by making this purchase. We did our best to supply you with an efficient and dependable machine.

Before first operation of your Admiral 36, read these instructions carefully. They will inform you in detail about operation of the item and contains valuable information for service and maintenance. The exclamation mark symbol  has been used in this manual at several places and identifies particular areas that are of essence for your safety. Please pass all safety instruction on to



Caution! Prior to first operation, read the manual carefully, and strictly comply with the instructions contained. When performing cleaning and service work and before replacing any parts or commencing conversion of any function, turn the machine OFF and disconnect the battery plug.

This manual always should be kept in the storage box located in the right-hand side door.



Please comply with the "General provisions for safety" (p. 36 to 37).

Proper use

The Admiral 36 vacuum scrubbing machine has been designed exclusively for floor cleaning, such as wet scrubbing and vacuum cleaning and, with the pre-sweeping equipment for dry sweepin. Whatever sort of use beyond the specified range will be deemed improper use; the manufacturer cannot be held liable for consequential damage.

The term of proper use also includes compliance with the manufacturer's instructions about operation, maintenance and repair.

The Admiral 36 may be used by persons only that are familiar with the machine and are aware of possible hazards involved.

The appropriate Accident Prevention Regulations as well as applicable general regulations about safety and health at work will have to be complied with. Modifications made to the machine in absence of the manufacturer's consent will relieve the manufacturer from a possible liability for consequential damage.



Caution! This machine is not suitable for evacuation of dusts dangerous to health.

Acceptance of the machine

Upon arrival, check your consignment for possible transit damage. Please have the railway authorities or the freight forwarder confirm such damage and mail your damage report and waybill to:

PowerBoss Inc.
175 Anderson Street
Aberdeen, NC 28315 U.S.A.
Telephone: (910) 944-2105 ·
Fax: (910) 944-740



General safety instructions

Apart from the information contained in this manual, the generally applicable legal provisions for safety and prevention of accidents must be adhered to. Do not put this manual aside without having read it, even if you did already operate similar ground cleaning equipment before. Allow yourself the time to do so, in order to save time at a later moment. The operator has to use the machine in accordance to its intended fields of application. During driving operation, he has to take account of the local conditions and when working, he has to pay attention to other persons, in particular to children. Nobody is allowed to stay within the zone of danger.

The warning and instruction plates attached to the Admiral 36 give important advice about safe operation. Before starting to work, the operator has to check that the Admiral 36 and its working implements are in proper and safe

Caution! The protective cover of brushes/drive plates must only be removed for maintenance or transport purposes and with the motors being turned off. Do not perform cleaning work without the covers being shut and locked.

Machines that are not in perfect condition must not be used.

It is indispensable to get acquainted with all attachments and controls, as well with their function, before operation begins. Once you have started to work, there will be no time to do so.

Operation

Ground sweepers may be operated only by appropriate persons who have been trained for such work, who have testified their capability to the owner of the unit or his authorized representative, and who have been ordered explicitly by him to operate the machine.



The machine may be used only on those areas as clearly specified by the owner or his authorized representative.

Never leave the machine unattended as long as the motors are running

and the machine is not protected against unintended movements. To prevent the machine from being used by unauthorized persons, the control key must be removed such the the travel drive is blocked.

When transporting the Admiral 36, shut down the motors of the working implements.

The operator has to use the machine in accordance to its intended fields of application. During driving operation, he has to take account of the local conditions, and when working, he has to pay attention to other persons, in particular to children.

Use only cleaning agents suitable for automatic machines (low foaming), and adhere to the instructions for use, disposal and precautions specified by the cleaning agent's manufacturer.

Caution! Never collect explosive fluids, undiluted acids and solvents!

This includes e.g. gasoline, paint thinners or fuel oil, which – when penetrating the air being taken in – may form explosive vapors or mixtures; moreover acetone, undiluted acids and solvents if they should be aggressive to the material used for the machine components.

Caution! This machine is not suitable for evacuation of dusts dangerous to health.

The machine must not be operated in areas endangered by risks of explosion. The machine may be used only for hard floorings in indoor areas and for operation on plane areas with a maximum inclination of up to 2%. Driving e.g. on ramps with a maximum inclination of 10% is only allowed for transportation. Uphill drive must not exceed 1 minute and particular care has to be taken.

Repair, maintenance and cleaning work must only be performed if the master key is removed.

Before working on the electrical system, be sure to disconnect the battery plug.

Taking other persons than the operator with the Admiral 36 is not allowed. If the Admiral 36 is equipped with a driver seat, it may only be turned on when the operator is seated (seat switch).

A perfect maintenance of the machine mainly helps preventing accidents. When performing repair, maintenance, setting or other work the appropriate tools have to be used. Other spare parts than the genuine PowerBoss spare parts must at least equal the original parts as far as the safety standards are concerned.

The Admiral 36 has to be checked by an expert in regular inter-

ervals for its proper and safe operation (we recommend a check once yearly at least) and after modification or repair.

The Admiral 36 must be equipped by brushes and pads as requires the manufacturer (refer to section "Technical data"). Using other brushes/pads than indicated affects your safety.

Do not clean the machine by means of vapor jet or high pressure cleaning equipment.



For an increased danger of tilting, the pneumatic tire equipment of the Admiral 36 is not admissible.

Do not allow water to enter any electrical parts.

Notes on warranty

The terms of the sales contract apply. Damages are not subject to warranty if they are due to non-compliance with the maintenance and service provisions. Any maintenance work has to be performed by an authorized PowerBoss service work-shop and confirmed in the „maintenance certificate“ which is the warranty document. The following is excluded from warranty:

natural wear and tear after overload, fuses and damages caused by inexperienced handling and unauthorized modification of the machine.

Moreover, any claim for warranty becomes extinct if damages at the machine are caused by fitting of parts or accessories without PowerBoss's prior and explicit consent or by non-compliance with the maintenance instructions.

Method of operation of Admiral 36

A squeegee and suitable brushes or pads are required for wet cleaning of hard floorings.

The rotating brushes scrub the floor thoroughly, removing the dirt by means of suds, thus cleaning the floor. The soiled water is drawn in during the same cycle by means of the squeegee. This way the floor can be stepped on immediately after-wards; it is dry and clean.

Useful advice for perfect work

Prior to wet cleaning it is necessary to sweep the floor. The Admiral 36 carries out this work if equipped with the optional pre-sweeper (accessories). This way, not only the cleaning efficiency is improved, but wear of the machine will be substantially reduced at the same time. If floors are particularly dirty or if wax has to be removed (basic cleaning), the floor should be treated twice. During the first cycle, the floor is scrubbed with a cleaning agent selected according to the degree of dirt encountered, the vacuum system remaining turned off and the squeegee remaining lifted.

Allow the cleaning agent to act on the floor for approx. 5 or 10 minutes, complying with the manufacturer's instructions, then scrub the floor once again while the vacuum system is turned on and the squeegee is lowered.

How to take the machine into operation

Assembly

When being supplied to you, the Admiral 36 is packed in a cardboard box. The floor consists of a wooden platform where the machine is fixed by means of plastic straps. Open the box from its bottom side and remove it by pulling upwards. After detaching the plastic straps, you now can take the machine from the platform

Installation of brushes

Refer to paragraph "Installation/Removal of brushes" on page 54.

Installation of squeegee

Refer to paragraph "Installation of squeegee" on page 56.

Note: For ease of compliance with the appropriate safety regulations, we recommend to use the above-mentioned batteries. Batteries and charger units are matched; therefore only use the batteries and charger units specified by us in order to comply with the provisions for safety. We can grant full warranty only if those units are used.



Whenever working on the electrical system, disconnect the battery plug. The seat hood has to be opened during the charging procedure to preclude formation of an ignitable gas mixture (oxyhydrogen).

Battery systems	
Battery system A Tray-type battery, 24 V/ 320 Ah ₅ , PzS, Aquamatic automatic battery charger unit 24 V/35 A characteristic line IUlola and IUloU, 230 V/AC	7450 4003
Battery system B Tray-type battery, 24 V/ 280 Ah ₅ , PzS, maintenance-free automatic battery charger unit 24 V/35 A, characteristic line IUlola and IUloU, 230 V/AC	7451 4003
Battery set C Drive battery 6 V/ 180 Ah ₅ , maintenance-free Battery charger unit 24 V/35 A, characteristic line IUlola and IUloU, 230 V/AC Cable set Battery bowl with holder	7411 4003 7412 7723
Battery set D: Battery, 6 V/240 Ah GiV Battery tray with cable set automatic battery charger unit 24 V/35 A, characteristic line IUlola and IUloU, 230 V/AC	7401 7403 4003
Battery system E: Battery exchange system for extended running times Through battery 24 V/240 Ah, PzS, Aquamatic**) Insert for battery exchange system Trailer for battery exchange system**) Automatic battery charger 24 V/35 A, characteristic line IUlola and IUloU, 230 V/AC **)2 = minimum quantity, to enable exchange	7334.02 7301 7302 4003
Tray-type battery dimensions: length 424 mm (in direction of travel), width 522 mm, height 462 mm	

Battery charge warning unit (Low discharge sensor)

The Admiral 36 is equipped with a charge condition monitor to preclude poor battery charge conditions. This monitor is integrated in the electronic system and factory-set for Sonnenschein "Gel" maintenance-free batteries.

Using other batteries requires modification of the low-discharge sensor settings.

Note: The low-discharge sensor settings should be carried out by your local PowerBoss service center.

Charger units

Power connection of the charger unit is effected via the power supply with earthing-contact plug.

Mains voltage: 230 V/AC

Mains protection: 10 or 16 A slow

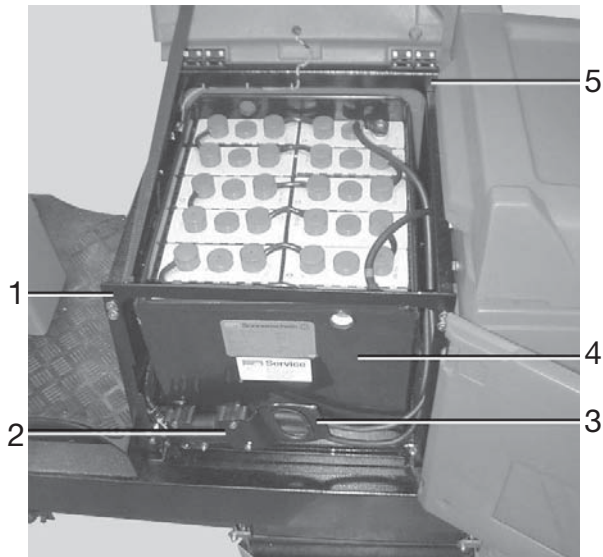

- 1 Brace
- 2 Device plug
- 3 Battery plug
- 4 Tray-type battery
- 5 Brace including driver seat

Installation of battery Battery system A and B

How to install the tray-type batteries
24 V / 320 Ah or 24 V / 280 Ah

- Open the doors at the left and right side
 - Tilt the driver seat upwards to the right
 - Dismount brace (1) at the left side (4 screws)
 - Remove plug of the seat switch line
 - Dismount brace (5) including seat at the right side and set aside (do not remove belt)
 - Swivel device plug
 - Place tray battery (4) by means of a lifting unit or a fork-lift truck into the machine from the left side.
- Note:** Only use lifting and transporting facilities e.g. lifting tackle according to VDI 3616. Cells, connectors or cables must not be damaged by usage of hooks.
- Check the coding of battery, device and charger plugs and modify as required according to the instructions on page 41 and 42.
 - Link battery and device plugs (pay attention to tight fit)

- Mount left brace (1) and brace (5) including driver seat
- Connect the line to seat switch.
- Close side doors and tilt the driver seat downwards
Proceed to dismantling in inverse order

Battery system C and D

- Open the doors at the left and right side
- Tilt the driver seat upwards to the right
- Place the batteries 6 V/180 Ah or 6 V/240 Ah into the battery compartment and connect the poles with the battery lines
- Check the coding of battery, device and charger plugs and modify as required according to the instructions on page 41
- Close side doors and tilt the driver seat downwards
Proceed to dismantling in inverse order.

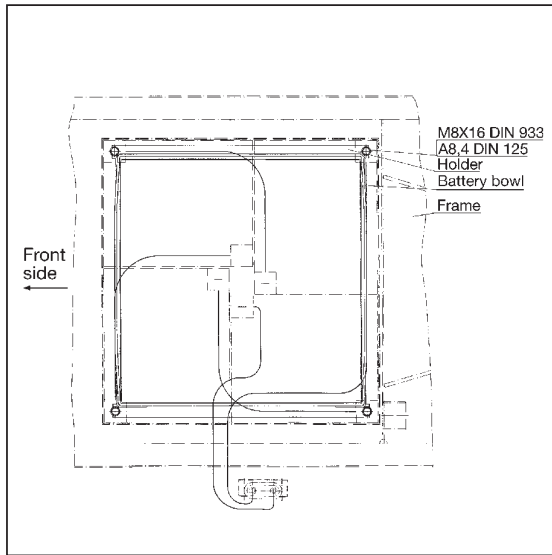

4 batteries 6 V/180 Ah

Battery systems E

Details see separate manual for battery exchange system.

Taking into operation, maintenance and service of batteries

See enclosed leaflet 88-60-2556
"Instructions for drive batteries"

Plug connection coding

All battery plugs at machines, batteries and battery charger units have to be coded with the colored coding pins according to the battery type and the nominal voltage.

The charger unit plugs are/will be set in the factory according their characteristic such that a modification of the characteristic (in relation to the battery type) requires changing of the plug coding.

Plug case of **charger units:**

Gray for fluid-filled batteries
Green for maintenance-free Gel batteries

Plug case of **machine:**

Yellow for both battery types

Socket case of **battery:**

Gray for fluid-filled batteries
Green for maintenance-free Gel batteries

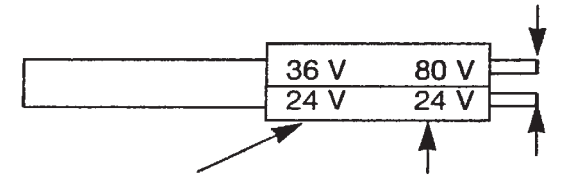

Nominal plug voltage is indicated on each side of the hexagon (letters upside down)

Indication for nominal socket voltage accordingly

Replacing the coding plug by pressing together the ends with pliers.

Press together for removal.

Insert coding plug such that the nominal voltage inscription is visible through the case window. Socket and plug only with the same nominal voltage!

The following three conditions must be fulfilled for the complete system:

- 1) Voltage coding must be the same for all sockets and plugs
- 2) Coding pin color in the machine = yellow
- 3) Coding pin color in the charger unit = the same as for the battery plug according to battery type

**Coding system in the charger unit for fluid-filled and dry batteries (Gel batteries)
Example 24V**

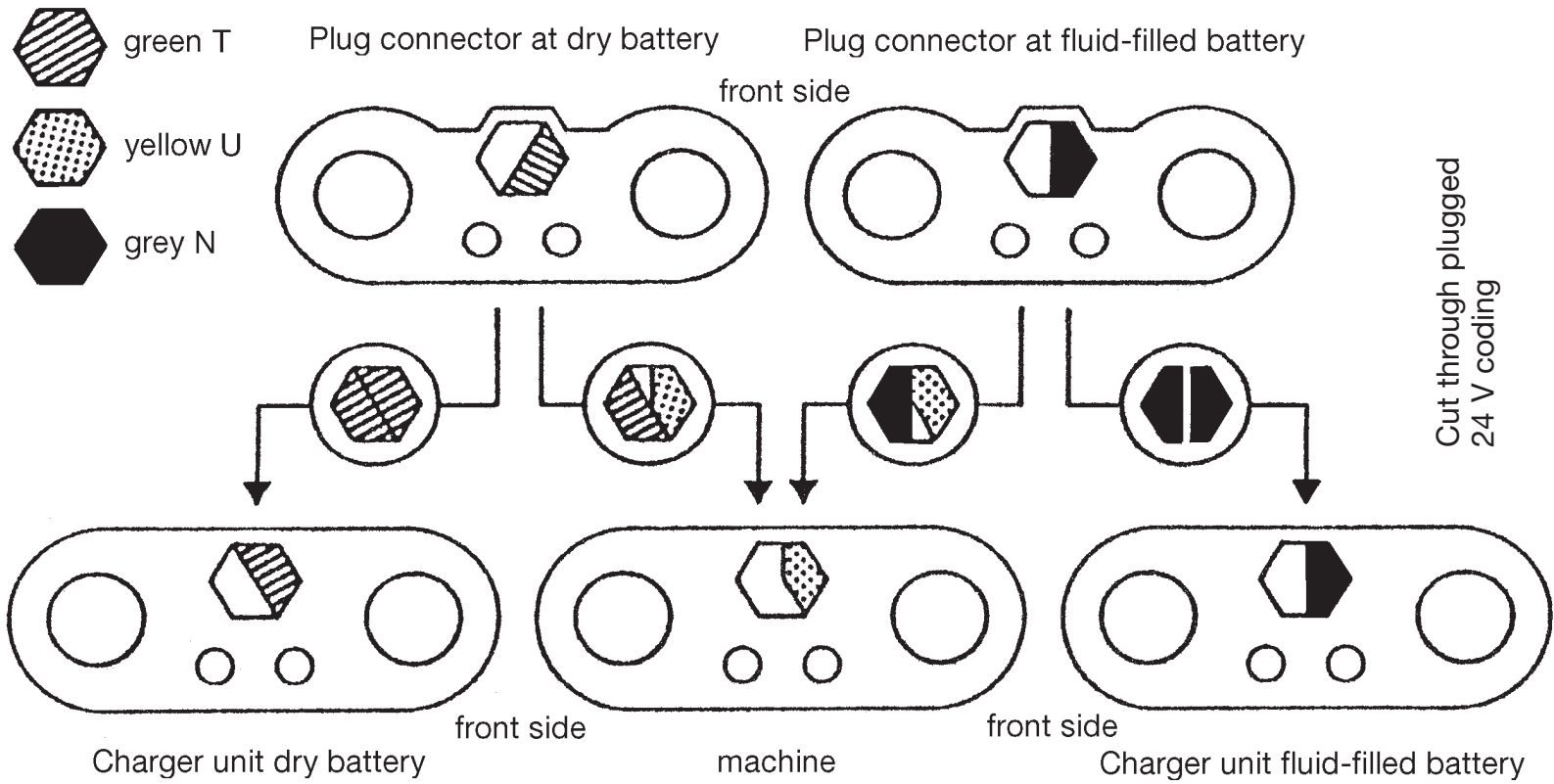

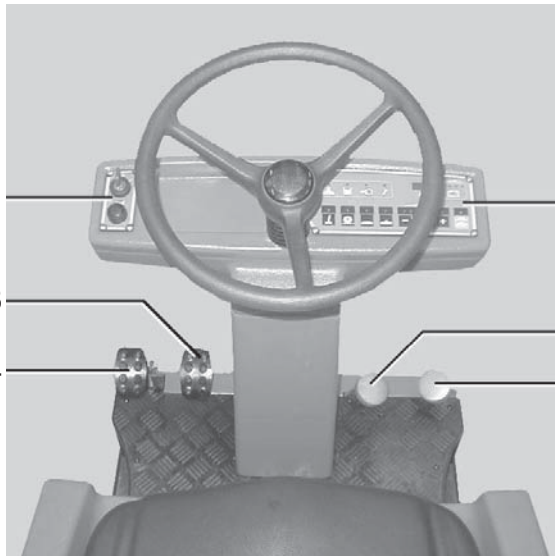

- 1 Left-hand control panel
- 2 Right-hand control panel
- 3 Pedal for brush/pad pressure
- 4 Parking brake pedal
- 5 Forward drive pedal
- 6 Reverse drive pedal

Operation

Operation elements

- 1 Left-hand control panel**
(Description see page 44)
- 2 Right-hand control panel**
(Description see page 44)



- 3 Pedal for brush/pad pressure** to adjust brush/pad pressure.
 - Slowly press pedal down until the pressure point is attained. Release pedal and it will lock. = increased brush/pad pressure and the yellow pilot lamp (I/C) alights
 - Actuate pedal beyond the pressure point and release. It will lift up to initial position. = normal brush/pad pressure and the pilot lamp extinguishes**Note:** An increased brush/pad pressure increases current consumption and brush/pad wear.

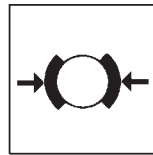

- 4 Parking brake pedal** actuates the parking brake at the rear wheels. Before leaving the machine the operator has to protect it by actuating the parking brake.

The pilot lamp (I/E) alights. When depressing the drive pedal a buzzer sounds. Depressing the blocking device will unlock the brake.

- 5 Forward drive pedal** allows modification of speed
 - slowly depress pedal until the required speed is attained.
 - release pedal and it will automatically return to the initial position and the machine slowing down simultaneously. Speed will be substantially reduced by actuating the reverse drive pedal.
- 6 Reverse drive pedal** allows modification of speed
 - slowly depress pedal until the required speed is attained and the buzzer sounds.
 - release pedal and it will automatically return to the initial position and the machine slowing down simultaneously.



The machine must only be started if the operator is seated down.

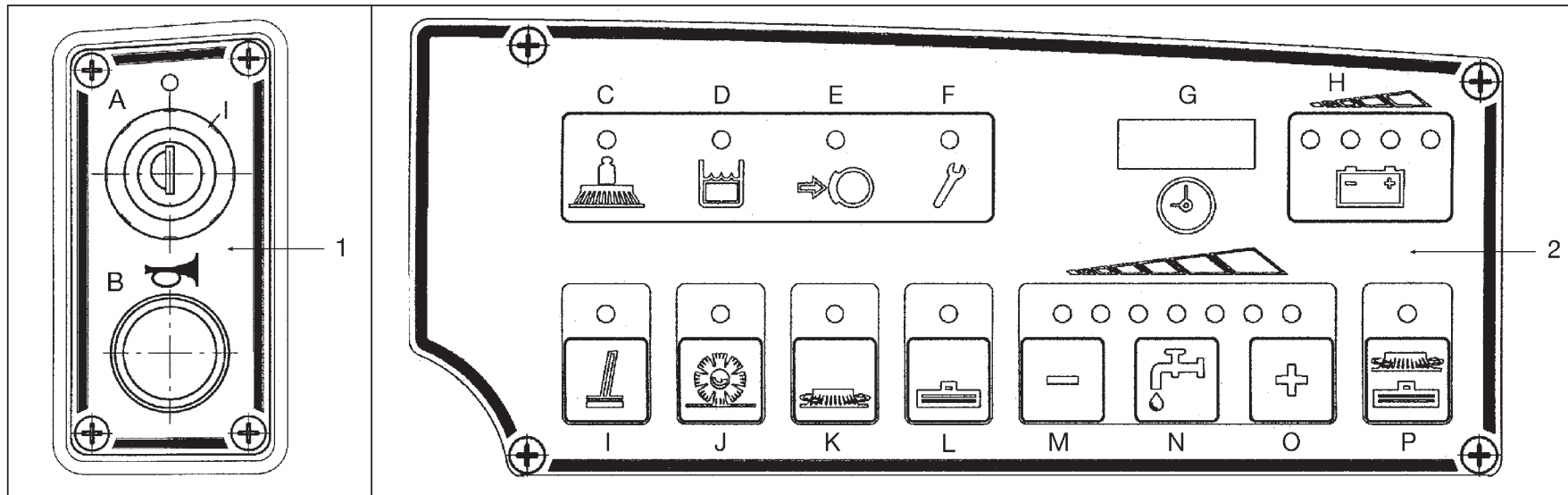

Control panels

Control panel 1

- A Key switch (ON/OFF)
- B Horn button

Control panel 2

- C Pilot lamp (yellow) for brush pressure
- D Pilot lamp (red) for max. filling level of soiled water tank
- E Pilot lamp (red) for parking brake
- F Pilot lamp (red) for fault display

- G Hourmeter/service display
- H Pilot lamp for battery charge condition
- I Key for additional scrubbing and vacuuming tool (ON/OFF) with pilot lamp (green)
- J Key for pre-sweeper (ON/OFF) with pilot lamp (green), optional*
- K Key for brush drive (ON/OFF) with pilot lamp (green)
- L Key for squeegee and suction turbine (ON/OFF) with pilot lamp (green)
- M Key for water flow reduction with pilot lamp (green)

- N Key for water infeed with pilot lamp (green)
- O Key for water flow raising with pilot lamp (green)
- P Key for brush drive, suction turbine (ON/OFF), with simultaneous brush head/squeegee (UP/DOWN) operation with pilot lamp (green)

* If the Admiral 36 is not equipped with the pre-sweeper option this key is inoperable. If depressed, the hourmeter will display "OP".

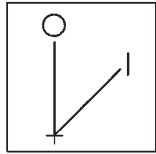
**A Key switch**

turns the electrical system ON/OFF and protects the machine against unauthorized use; moreover it holds the hourmeter display. With the switch in OFF position, all control functions are reset to the initial state (reset).

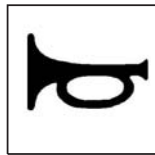
**B Horn button**

actuates the electric horn.

**C Pilot lamp (yellow) for brush pressure**

alights if the brush pressure pedal (II/3) is depressed

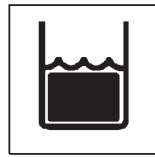
**D Pilot lamp (red) for max. filling level**

alights if the maximum filling level in the soiled water tank is attained.

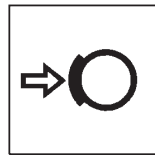
**E Pilot lamp (red) for parking brake**

alights if the parking brake pedal (I/4) is depressed. If the travel drive assembly is switched on a buzzer sound in addition.

**F Pilot lamp (red) for fault display**

alights in case of one of the following faults occurring:

- thermostat switch of the brush or drive motor has closed

- one of the fuses is defective or one of the electronic circuit-breakers tripped
- other faults

Electronic circuit breakers

In addition to the fuses, the Admiral 36 is equipped with electronic circuit-breakers for the main drives. In case of overload one of the electronic circuit breakers responds, the fault lamp (F) alights and an error code appears in the hourmeter display.

The reset can only be effectuated by turning the key switch to "OFF". If the electronic circuit-breaker trips again after re-starting, the cause has

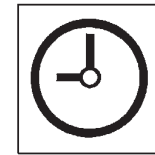
**G Hourmeter/service display**

displays the operation hours. The meter only counts if the consumers e.g. drive or brush motor, suction turbine or pre-sweeper are ON. A red dot at the right bottom of the display flashes simultaneously.

Service display

The service display is located in the hourmeter display.

When turning ON, the following sequence of information will appear in the hourmeter display:

- software status for 1 approx. second, e.g.

3. 0 1 5

- last error found, for approx. 2 seconds (points blink), e.g.

1. 2. 6. 1.

Note: If a defect is still existing, a buzzer sounds and the red display turns ON (F).

- hours run, e.g. during operation, the dot will blink.

0 2 1 5.

Note: on factory-new machines, the display may read when the key switch is turned to ON.

9 9 9 9.

This is an internal control code; display will change to 0 hours after not more than one hour.

The Admiral 36 is serviceable with this display.

Error display is active either.

If a malfunction occurs during operation, a 4-digit number will appear in the display, the 4 dots will start flashing simultaneously and the buzzer sounds.

Refer to page 61 for the error code numbers which you may remedy by yourself. If the machine does not operate correctly despite measures taken, denote the error code and advise your PowerBoss service

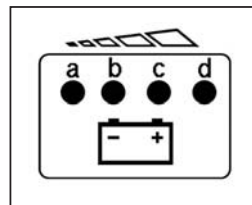

H Pilot lamp for battery charge condition

Upon turning ON the key switch, all green pilot lamps (b to d) alight in case of a perfectly charged battery. During operation the lamps b, c and d will successively extinguish as the battery discharges.

A flashing red light (a) indicates that operation will soon be interrupted and the buzzer sounds. After 3 more minutes, the red lamp alights permanently and the brush drive and the suction turbine will be switched OFF. The travel drive assembly remains activated. We recommend to recharge the batteries at the charging station as soon as possible.

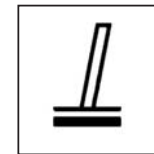

I Key for additional scrubbing and vacuuming tool

Note: this key is only operable if the Admiral 36 is equipped with the "additional scrubbing and vacuuming tool" option and the PowerBoss service center has programmed the machine accordingly. Otherwise, "-OP-" is displayed. This key turns the water pump and the suction turbine ON and OFF. The water and the vacuuming hose of the scrubbing tool have to be connected



J Key for pre-sweeper with pilot lamp (green), optional*

Note: this key is only operable if the Admiral 36 is equipped with the "pre-sweeper" option and the PowerBoss service center has programmed the machine accordingly. Otherwise, "-OP-" is displayed.

This key turns the pre-sweeper ON and OFF. The green pilot lamp alights if the pre-sweeper is turned ON. In case of a malfunction the fault lamp (F) alights and the error code appears in the service display.



K Key for brush drive with pilot lamp (green)

turns the brush drive ON and OFF. The green lamp alights if the brush head is lowered and the brushes rotate. In case of a malfunction the fault lamp (F) alights and the error code appears in the service display.

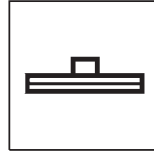

L Key for squeegee and suction turbine with pilot lamp (green)

is lowering/lifting the squeegee and turns the suction turbine ON and OFF. The green lamp alights if the squeegee is lowered and the suction turbine turned ON.

In case of a malfunction the fault lamp (F) alights and the error code appears in the service display.

Note: After lift-up of the squeegee the suction turbine continues operation for about 15 seconds and the pilot lamp (green) in the key flashes. This measure precludes soiled water from flowing out of the squeegee or the vacuuming hose back to the floor. If the soiled water tank is filled up, the suction turbine is switched off after approx. 3 to 5 seconds and the water supply of the brushes interrupted. These functions can be activated again after discharge of the tank.



M Key for water flow reduction

is used to reduce the water quantity supplied to the brushes/pads. The water quantity may be reduced by 7 stages from 5.5 liters to 1.0 liter per minute, each stage corresponding to one lamp

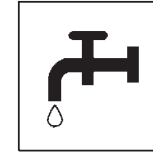

N Key for water infeed with pilot lamp (green)

is used to turn on or off the water infeed. When switching on the brushes/pads the last set water quantity is supplied automatically but may be modified via the (M) and (O) keys. The tool mode features this memory function as well. There, the water infeed may be adjusted from 0.5l to 1.0l per minute.



O Key for water flow raising

is used to increase the water quantity supplied up to max. 5.5 liters/minute.

P Key for brush drive, suction turbine with pilot lamp (green)

turns the brush drive assembly and the squeegee ON/OFF with a simultaneous lowering/lifting of the brush head and the squeegee. The green pilot lamp alights if the units are ON and lowered. In case of a malfunction the fault lamp (F) alights and the error code appears in the service display.

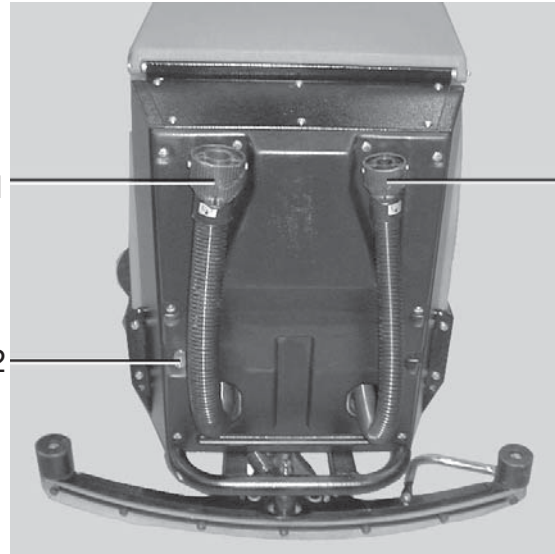

- 1 Drain hose for soiled water
2 Connection for additional scrubbing and vacuuming tool
3 Drain hose for fresh water



1 Drain hose for soiled water
is used for draining the soiled water.

Note: When work is finished, the soiled water tank has to be drained and rinsed.

Drainage of soiled water: Unhinge the drain hose and open the seal. The quantity drained-off can be regulated by rotation of the seal, which is completely opened, if required, by swiveling.

Re-close the seal by rotation to the stop, and attach the drain hose.

2 Connection for water hose of additional scrubbing and vacuuming tool

is used for connection of the water hose. The vacuuming hose has to be linked with the unit's vacuuming hose by means of a cylindrical adaptation.

3 Drain hose for fresh water

is used to drain the lye from the fresh water tank.

Note: the tank requires rinsing at regular intervals in order to preclude formation of residues.

Drainage of lye: Unhinge the drain hose and open the seal. The quantity drained-off can be regulated by rotation of the seal, which is completely opened, if required, by swiveling.

Re-close the seal by rotation to the stop, and attach the drain hose.

Caution: The legal regulations and the local provisions have to be complied with when discharging detergents.

Driving with the Admiral 36

Adjusting the driver seat

The driver seat has to be adjusted such that the operator is comfortably seated and the operation elements are within his reach.

Adjusting the driver seat lengthwise as follows:

- Tilt the seat upwards
- Unscrew the 4 screws below the seat and position it adequately, then tighten screws again

Starting

- Unplug battery plug from the charger unit and connect with the machine.



Before connecting the battery plug with the machine, switch off the machine by the key switch.

- The operator has to be seated on the Admiral 36 driver seat.

Note: The Admiral 36 is equipped with a protective circuit via a seat switch. If the operator has left the seat for 2 seconds, any unit is switched off and the brush head and the squeegee lifted.

If the operator sits down again, he may drive again after restarting the functions by actuating the key (I/P).

If the seat switch is not actuated with the machine being ON, the hourmeter display flashes.

- Switch on the key switch
- Release parking brake
- Slowly depress driving pedal until the desired speed is attained.

Stopping

- Release the pedal and the machine is slowed down (pedal returns automatically to its initial position)

Note: The slowing effect may be increased by actuating the reverse drive pedal.

Only stop the machine at a slope for a short time otherwise the motor may be overheated. The Admiral 36 should be stopped at a slope using the parking brake.

- Actuate the parking brake
- Switch off by key switch and withdraw the key.



Before leaving the machine, withdraw the key and actuate the parking brake on principle.

Only drive slowly on wet grounds especially when driving turns because of skidding hazard. Slow down when driving downhill turns because of the tilting risk.

Working with the Admiral 36

The driver has to read this manual carefully. The operation elements are represented by comprehensible symbols and facilitate familiarization. Proceed to the first driving trials on a clear training ground or road until the driver is acquainted with the elements and their functions.



Comply with the following safety instructions

When using the Admiral 36, the safety instruction generally applicable for using self-propelled working machines have to be complied with. Transporting persons on the Admiral 36 is strictly prohibited. The warning and instruction plates attached to the Admiral 36 give important advice about safe operation. Complying with the instructions is essential for your

Before starting to work, the operator has to check that the Admiral 36 and its working implements are in proper and safe operating condition. Do not operate the Admiral 36 without protective devices being installed.

Detergents

Important note:

Use only detergents suitable for automatic machines (low foaming). We recommend using our agents for cleaning and care, which are adapted to the Admiral 36. Those products comply with the provisions of the Detergents Act. Comply with the instructions for correct dosage of detergent. If there is much foam, this will affect the performance of the machine. Actually it indicates that there is excessive dosage or improper suitability of detergent for the existing kind of dirt. Detergent particles contained in the soiled water and not being used will cause formation of foam.

Please take the manufacturer's recommendations as a first basis. Tests made by yourself in practice then soon will make you find the ideal detergent and the perfect dosage applicable to it. Correct dosage will help you to save money and to take care of the environment.

Refilling the fresh water tank

- Open tank cover (III/1) and protect with the supporting bar (III/2)
- Refill fresh water according to the requirements into the tank (III/3) with a max. temperature of 50°C.
- Add detergent according to the manufacturer's instruction.
Note: in the soiled water tank the filling level must not get beyond the maximum mark.

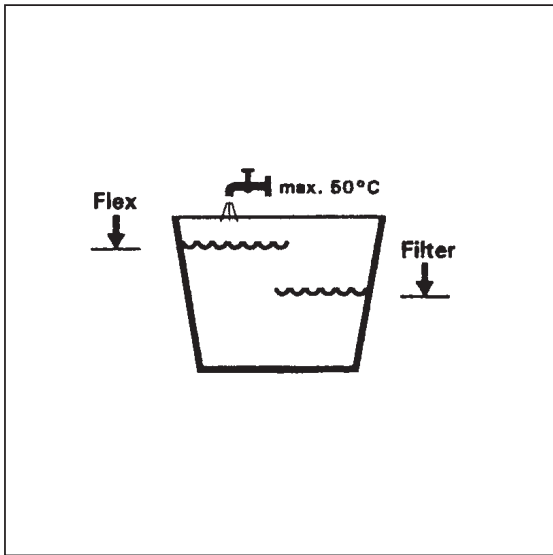

Filling level of the soiled water tank

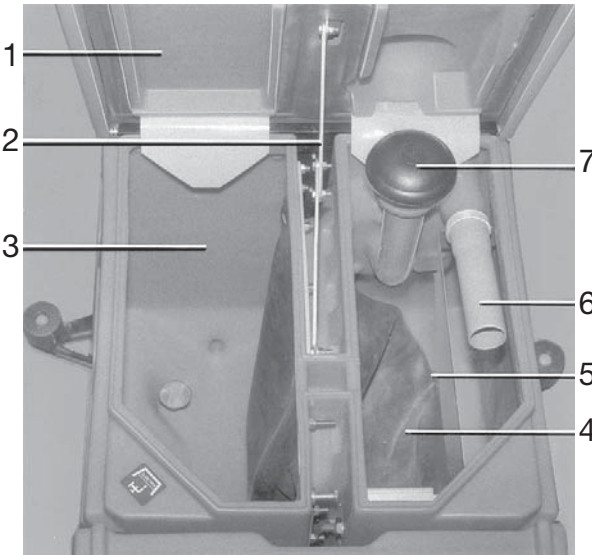

III

- 1 Tank lid
- 2 Supporting bar for tank lid
- 3 Fresh water tank
- 4 Flexible pane
- 5 Soiled water tank
- 6 Soiled water inlet
- 7 Intake socket for suction motor

Actuate the following operation elements of the Admiral 36 subsequently

- Turn the key switch ON
- Release parking brake (if locked)
- Actuate (I/P) key which enables the following functions:
 - brush head lowers
 - brushes rotate
 - squeegee lowers
 - suction turbine starts operation
 - lye blocking valve opens
- Turn On or OFF the lye supply by the (I/N) key and reduce by the (-) key or increase by the (+) key.
- Actuate the drive pedal until the desired speed is attained.

Note: After lowering the brush head, move the Admiral 36 immediately; otherwise the brushes might leave traces.

When work is finished:

- Stop the machine
- Lift up the brush head and the squeegee by the (I/P) key (the suction turbine continues operation for about 15 seconds)
- Turn OFF the key switch
- Actuate the parking brake
- Drain the soiled water tank and rinse
- Clean the sealing strips of the squeegee
- Check the intake filter (III/7) and clean if required

Note: Do not clean the machine by means of vapor jet or high pressure cleaning equipment but by means of a water hose (pressure: approx. 5 to 6 bar) and from the top to the bottom. Do not allow water to get into any opening, slits, on electronic modules, control panels or seals.

Do not allow water to get on the seat console as it may be collected on the battery stored below the seat, remove water if required.

Let the machine dry e.g. for the week-end. The use of aggressive and caustic detergents is not allowed. We recommend to clean the tanks at regular intervals (e.g. once daily after work has finished) in order to preclude accumulation of organisms dangerous to health.

Brushes			
degree of dirtiness	bristles fitted	PN	Qty.
light to medium	synthetic material PPN 0.5	7544	2
light to medium, structured-pattern floor	mixed synthetic material K 901	7547	2
medium to heavy	synthetic material PPN 0.8	7543	2
very heavy dirtiness and basic cleaning	SIC PA 6 grain 180, gray	7545	2
extremely heavy dirtiness and basic cleaning	SIC PA 6, 12 grain 120, green	7546	2
Super pads with drive plate			
cleaning method	colour	PN	Qty.
minor dirtiness	red	7551	2
maintenance cleaning	brown	7549	2
basic cleaning and heavy dirtiness	black	7550	2
Poly-pad (micro fibre pads)		7088	2
Accessories required: drive plate (pad holder) with Centerlock		7548	2

Brushes/pads

The Admiral 36 must be equipped with brushes/pads from the accessories kit, as required by the degree of dirtiness and kind of ground.



Only use the brush/pad types described above. Using other brush/pad types may affect your safety.

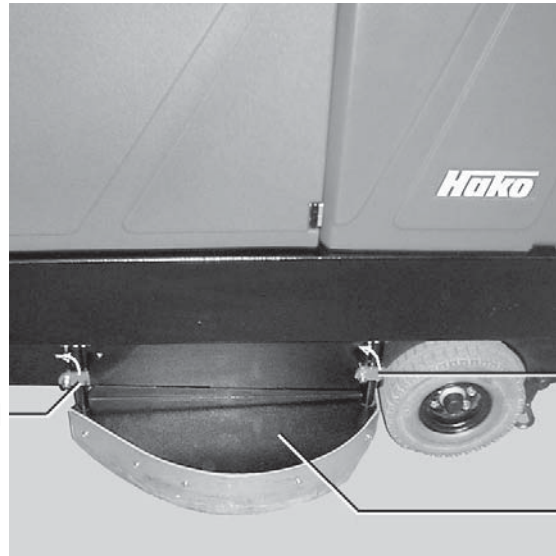

- 1 Front lock
- 2 Cover
- 3 Rear lock

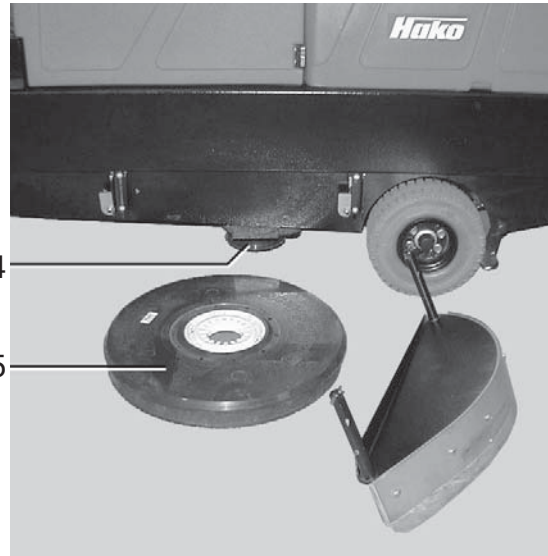

- 4 Catch
- 5 Brush/drive plate

IV

Removal of brushes /drive plate



Install and remove brushes/drive plate only with the brush drive being turned OFF.

- Open front and rear lock (IV/1 and 3)
- Lift cover (IV/2) slightly and remove
- Press the brush/drive plate evenly down (do not skew), unlock and remove
- Replace cover (IV/2) and lock.

Note: The brushes are equipped with a water retaining ring which reduces the water consumption during scrubbing significantly.

Installation of brushes/drive plate



Install and remove brushes/drive plate only with the brush drive being turned OFF.

- Open front and rear lock (IV/1 and 3)
- Lift cover (IV/2) slightly and remove
- Place brush/drive plate (IV/5) on the catch, rotate slightly until the teeth

take hold. Then pull upwards until the hooks lock. Rotate the brush/drive plate to check whether all hooks are locked.

- Replace cover (IV/2) and lock.



Do not operate the Admiral 36 without covers

Soiled and fresh water tanks

The Admiral 36 is equipped with a soiled water tank (III/5) and a fresh water (lye) tank (III/3).

Either tank is equipped with flexible pane. Soiled water is fed via the suction hose through the inlet socket (III/6) into the soiled water tank.

A floating switch in the soiled water tank precludes overflowing. If the floating switch is activated, the suction procedure is interrupted approx.

3 to 5 seconds later. This measure prevents the water from penetrating the suction turbine.

Note: When work is finished the soiled water tank on principle must be drained and rinsed.

Rinse the floating switch as well.

The seal at the outlet hose should be cleaned at regular intervals. If required grease the O ring slightly. Rinsing of the suction hose to the squeegee is possible from the top via socket (III/6).

Refer to page 48 for detailed information on draining of the soiled



Caution! For disposal of soiled water and lye, the legal provisions have to be complied with.

Removal of the filter

- Remove cap of the intake socket (III/7)
- Remove ring filter and clean (replace defective filter)

Note: Upstream the fresh water outlet, the tank bottom is equipped with a sieve which can be unscrewed. Check this sieve at regular intervals and clean if required.

Squeegee

The Admiral 36 is equipped with a parabolic-shaped 110mm squeegee. The squeegee holder (V/4) is fixed to the Admiral 36, allowing swiveling and oscillating movements. The squeegee, protruding at the side, evades obstacles in the machine's path and is made swivel backwards. Before starting to work, check the squeegee for possibly collected foreign matter and the sealing strips for proper condition.

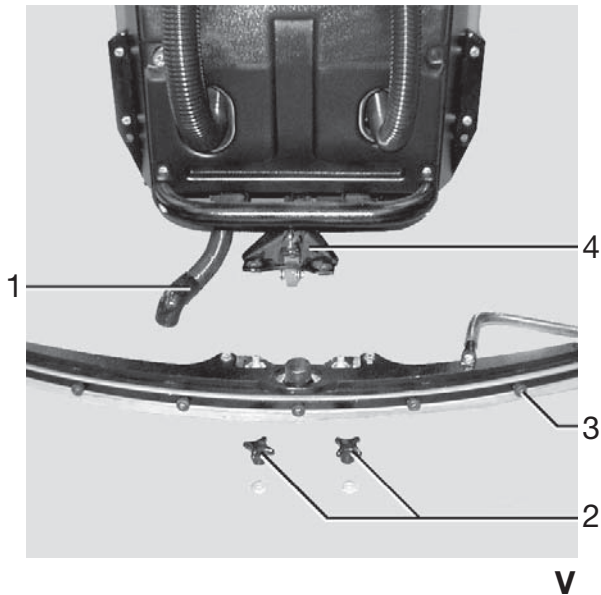

- 1 Suction hose
- 2 Nuts with toothed washers for squeegee fixing
- 3 Knurled nuts for sealing strips
- 4 Squeegee holder

Note: The rubber strap located at the rear fender is used to fasten the suction hose in case of dismantled squeegee.

Installation/Removal of squeegee

- Lower squeegee and turn OFF the key switch
 - Push squeegee with the threaded pins into the corresponding slits at the squeegee holder (V/4)
 - Place washers and fasten squeegee using the nuts with the toothed washers (V/2)
 - Place suction hose ((V/1) at the socket of the squeegee.
- Removal is performed in inverse order.

Electrical equipment

The electrical equipment of the Admiral 36 uses a tension of 24 V. Three types of battery systems may be used (refer to "Battery systems", page 39).

Towing

If the Admiral 36 has to be towed e.g. due to discharged batteries or faulty drive assembly, proceed as follows:

- Remove the front right and left bolts and the deflector rollers
- Pull the belt through the lower holes for the bolts

Note: Tow the Admiral 36 at a speed of max. 2 km/h and for a short distance only. Otherwise the drive motor may be damaged. If the machine is pushed too fast, the drive

Technical data		
Dimensions length with squeegee and sweeper width without/with squeegee height above driver seat	cm cm cm	191/237 93/110 137
Working width brush head squeegee	cm cm	88 110
Surface performance theoretical at 6km/h, up to max. Running time, up to	m ² /h hours	5300 4
Weights deadweight dry, without batteries	kg	350
Total weight (operational)	kg	750
Performance data driving speed forward/reverse, up to max. uphill ride capacity, max. full (operational)/empty (1 minute max.) ramp angle without/with squeegee (max.) front/rear turning circle diameter (external) with squeegee	km/h % degree m	6/2.8 10/15 10.5/9 2.8
Wheels drive wheels		3.00-4
diameter specific wheel pressure front/rear	∅ N/mm ²	250 0.44/0.62

Technical data		
Tank capacities Flexible pane tank fresh and soiled water tank flow rate, max.	l l/min.	138 5.5
Brush head number of brushes/diameter brush speed brush pressure, up to max. specific brush pressure	Qty./cm 1/min kg N/cm ²	2/46 240 60 0.25
Vacuum suction air throughput vacuum pressure	m ³ /h mbar (mm C.W.)	110 162/1620
Electrical equipment service voltage wattage (max.) protection class brush motor M4/M5 suction turbine M3 drive motor M1 water pump M2 lifting element (brush) M6 lifting element (squeegee) M8 pre-sweeper M7 fuse F1 / total fuse F2 / travel drive fuse F3 / pre-sweeper fuse F4 / horn fuse F5 / drive control circuit	Volt/DC W VDE 0700 W W W W W W W W A A A A A	24 3500 III 2x820 550 820 100 15 15 200 125 63 10 10 5

<p>Noise level</p> <p>sound pressure as per DIN 45635 part 1 under normal conditions of use at the operating area</p>	<p>dB (A)</p>	<p>66</p>
<p>Vibrations</p> <p>The frequency weighted acceleration measured according to EN 1033 which have an effect upon the upper limbs (hand-arm-system) amounts under normal working conditions not more than</p> <p>The frequency weighted acceleration measured according to EN 1032 which have an effect upon the body (feet and backside) amounts under normal working conditions not more than</p>	<p>m/s²</p> <p>m/s²</p>	<p>2.5</p> <p>0.5</p>

Maintenance work

Compliance with our recommendations concerning maintenance work will give you the certitude of always having a machine at your disposal, which is ready to work and in good operating condition. It is better to take precautions than to repair damages – and less expensive! Please contact your local PowerBoss service center; the people there will be glad to perform that work for you. There, well-trained personal and genuine PowerBoss spare parts are at your disposal. In case of any inquiries or orders for spare parts, please always quote the machine's serial number mentioned on the nameplate.

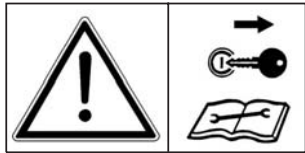

When cleaning or servicing the machine, and when replacing any parts, shut off the motors and on principle disconnect the battery plug; moreover

take precautions so as to protect the unit against unintentional movements or against being inadvertently started. For reasons of safety during cleaning and/or maintenance work in or on the tank, the tank lid – when lifted – must be secured so as to prevent accidental closing or tilting down. The machine may be taken into operation only if all guarding devices are fitted and in protective position. As far as possible, cleaning should not be done by hand, but using appropriate tools or equipment. Maintenance, repair and adjustment work may be carried out only by means of suitable tools and by people trained in the factory. When using or replacing batteries, battery connection cables, battery charger units comply with the manufacturer's instructions. For reasons of safety, only genuine PowerBoss spare parts must be used. **Note:** Do not clean the machine by means of vapor jet or high pressure cleaning equipment but by means of a water hose (pressure: approx. 5 to 6 bar) and from the top to the bottom. Do not allow water to get into any opening, slits, on electronic modules, control panels or seals.

Do not allow water to get on the seat console as it may be collected on the battery stored below the seat. Let the machine dry after cleaning e.g. for the week-end. The use of aggressive and caustic detergents is not allowed.

The legal regulations and the local provisions have to be complied with when discharging detergents. The Admiral 36 is equipped with a service display. If a malfunction occurs during operation, e.g. a defective fuse, a 4-digit number will appear in the display (hourmeter), the 4 dots will start flashing simultaneously and the buzzer sounds. This 4-digit number advises the service technician in detail on the last error found.

This facilitates fast repair action. The following table lists some of the possible errors displayed. You may

Service display

Error code displayed	Malfunction	Possible cause	Remedy
1. 2. 5. 2.	Brushes stop	<ul style="list-style-type: none"> ● Cord or other matter accumulated between brush and shaft ● Rubber protector at the external brush head side loosened and slipped under the brush 	<ul style="list-style-type: none"> ● Remove cord or other matter ● Adjust rubber protector and fasten (ground clearance 2 to 3 mm)
1. 2. 6. 1.	Brushes stop	<ul style="list-style-type: none"> ● Brushes blocked by foreign matter 	<ul style="list-style-type: none"> ● Check brush head for foreign matter and remove
3. 4. 5. 1.	Cleaning function turns OFF	<ul style="list-style-type: none"> ● Parking brake actuated ● Drive chain wheels stuck by foreign matter 	<ul style="list-style-type: none"> ● Release parking brake ● Remove foreign matter
1. 2. 6. 3.	Brush lift-out and brush motor turn OFF	<ul style="list-style-type: none"> ● Foreign matter between brush head and machine ● Brush head stuck 	<ul style="list-style-type: none"> ● Remove foreign matter ● Take machine from the step on a higher step
1. 4. 6. 1	Squeegee lift-out and suction turbine turn OFF	<ul style="list-style-type: none"> ● Squeegee stuck or foreign matter between squeegee and machine 	<ul style="list-style-type: none"> ● Adjust squeegee or remove foreign matter
2. 2. 5. 2.	Broom in the pre-sweeper turns OFF (only with pre-sweeper equipment)	<ul style="list-style-type: none"> ● Cord or other wrapped around the broom and blocking it 	<ul style="list-style-type: none"> ● Remove foreign matters and switch on circuit-breaker

Maintenance work	daily	service hours		
		every 50	every 200	every 500
Recharge the batteries according to the charger unit indications	●			
Empty and clean (rinse) the soiled water tank	●			
Check the sealing strips of squeegee for good condition	●			
Check the squeegee for possibly collected foreign matter and clean it, if required	●			
Check the strainer in the fresh water tank and the ring filter in the intake socket of the soiled water tank; clean it if required	●			
Check battery acid level, top up with distilled water as required (only with PzS)		●	●	●
Clean battery poles and grease them adequately if required		●	●	●
Check the suction hose between squeegee and soiled water tank for tight fit and possible damages		●	●	●
Check the squeegee sealing strips for wear, renew them if required		●	●	●
Check the sealing strip of the brush head cover; renew them if required		●	●	●
Check the brushes and the water retaining ring for tight fit and for wear, renew if required		●	●	●

Maintenance work	daily	service hours		
		every 50	every 200	every 500
Check the float switch for proper operation		●	●	●
Check the tank lid seal; renew if required		●	●	●
Check brake and pedal locking for proper operation		●	●	●
Grease squeegee holder and all hinge points of brake and brush pressure pedal		●	●	●
Check wheel attaching screws and tighten if required (25 Nm)		●	●	
Check the flexible pane (diaphragm) for possible damages. Note: Renew the diaphragm pane immediately if defective!		●	●	●
Check steering for slackness, adjust pinion of the steering chain or replace if required		●	●	
Grease steering chain		●	●	
Grease steering bearing				●
Check fresh water supply to the brushes (solenoid valve and pump function)		●	●	●
Check roller chain for travel drive for tension, adjust or renew and grease if required		●	●	

Maintenance work	daily	service hours		
		every 50	every 200	every 500
Check direction of brush rotation		●		
Remove carbon dust from electric motors; check the carbon brushes for easy operation and wear; renew the carbon brushes as required				●
Remove carbon dust from travel drive motor; check the carbon brushes for easy operation and wear; renew the carbon brushes as required, renew carbon brushes every 1000 hours				●
Clean ventilation grating of the brush motors from flyings or dirt			●	

Revision F
Effective November 1, 2008
PowerBoss Made Simple Industrial Limited Warranty

Minuteman International owner of PowerBoss warrants to the original purchaser/user that the product is free from defects in workmanship and materials under normal use. PowerBoss will, at its option, repair or replace without charge, parts that fail under normal use and service when operated and maintained in accordance with the applicable operation and instruction manuals. All warranty claims must be submitted through and approved by factory authorized repair stations.

This warranty does not apply to normal wear, or to items whose life is dependent on their use and care. Parts not manufactured by PowerBoss are covered by and subject to the warranties and/or guarantees of their manufacturers. Please contact Minuteman International for procedures in warranty claims against these manufacturers.

Special warning to purchaser -- Use of replacement parts not manufactured by PowerBoss or its designated licensees, will void all warranties expressed or implied. A potential health hazard exists without original equipment replacement.

All warranted items become the sole property of Minuteman International or PowerBoss or its original manufacturer, whichever the case may be.

PowerBoss disclaims any implied warranty, including the warranty of merchantability and the warranty of fitness for a particular purpose. PowerBoss assumes no responsibility for any special, incidental or consequential damages.

This limited warranty is applicable only in the U.S.A. and Canada, and is extended only to the original user/purchaser of this product. Customers outside the U.S.A. and Canada should contact their local distributor for export warranty policies. PowerBoss is not responsible for costs or repairs performed by persons other than those specifically authorized by PowerBoss. This warranty does not apply to damage from transportation, alterations by unauthorized persons, misuse or abuse of the equipment, use of non-compatible chemicals, or damage to property, or loss of income due to malfunctions of the product. If a difficulty develops with this machine, you should contact the dealer from whom it was purchased.

This warranty gives you specific legal rights, and you may have other rights, which vary from state to state. Some states do not allow the exclusion or limitation of special, incidental or consequential damages, or limitations on how long an implied warranty lasts, so the above exclusions and limitations may not apply to you.

	Travel*	Labor	Parts	Engine	Extended Warranty	Costs
Walk behinds						
Battery sweepers	Ninety days	One year	One year	N/A	2 years Parts + Labor (or 2000 Hours)	2%
IC sweepers	Ninety days	One year	One year	Through manufacturer	2 years Parts + Labor (or 2000 Hours)	2%
Battery scrubbers	Ninety days	Two years	Three years	N/A	3 Years Parts + Labor (or 3000 Hours)	2%
Riders						
Battery scrubbers	Ninety days	Two years	Three years/2000 hrs	N/A	3 Years Parts + Labor (or 3000 Hours)	2%
IC sweeper/scrubbers	Ninety days	Six months	Two years/2000 hrs	Two years/3000 hrs**	2 years Parts + Labor (or 2000 Hours)	3%
IC sweepers	Ninety days	Six months	Four years/3000 hrs	Five years/3000 hrs**	4 Years Parts + 2 Years Labor (or 4000 Hours)	3%
Exceptions						
Apex series sweeper	Ninety days	One year	One year/1000 hrs	One year/1000 hrs**	2 years Parts + Labor (or 2000 Hours)	3%
6X sweeper	Ninety days	Six months	Two years/2000 hrs	Two years/2000 hours**	2 years Parts + Labor (or 2000 Hours)	3%

Tank Bladders

Eight years/ no additional labor

Polypropylene plastic tanks

Ten years/ no additional labor

Batteries

0-3 months full replacement, 4-12 prorated credit

Chargers

One-year replacement

Replacement parts

Ninety days

***Two-hour cap**

****Through engine manufacturer. See section 3 of warranty manual for engine warranty exceptions**

***** Based upon dealer's certification status**

Extended Warranty MUST be signed up within 30 days of delivery to End User (Dealer has 1Year from Receiving Machine to Sign up extended Warranty)

Extended Warranty Cost is based on Invoice Price multiplied by the Percentage listed in the Extended Warranty Column

All above labor and travel reimbursed at 65 or 75% of the published shop rate.



“The Power of Clean”

PowerBoss, Inc 175 Anderson Street P.O. Box 1227- Aberdeen North Carolina 28315

Phone: 800-982-7141 - Fax: 1-800-277-7141 Local: 910-944-2105 Fax: 910-944-7409 e-mail: techsupport@powerboss.com