

Parts Catalog

Nautilus & Nautilus CE

Rider Scrubber/Sweeper

Models: Diesel, Gasoline, & LPG



PREFACE

Thank you for your purchase of the new industry standard for scrubber/sweepers. PowerBoss® takes great pride in offering the most dependable, reliable and best value in industrial power scrubbers and sweepers. We set the standard.

Our Customer Service Department would like to hear from you. If you see any errors, omissions or something that needs clarification in this Parts Catalog please let us know. We are working hard towards continually improving our processes to bring you the best you deserve. Please copy the form below, fill out and comment on how you found our catalog.

Thank you!
The PowerBoss Team

Name: _____

Title: _____

Company Name: _____

Address: _____

Country: _____

Type of equipment or model number: _____

Comments: _____

Please return to:
Customer Service Manager
PowerBoss®, Minuteman International, Inc.
14N845 U.S. Route 20
Pingree Grove, Illinois 60140 USA

Phone: (800) 323-9420
Email: tech@powerboss.com

This is the Parts Catalog for the PowerBoss® Nautilus Scrubber/Sweeper machine.

This catalog covers all Standard Nautilus machine variations beginning August 2015.

We believe this machine will provide excellent service for many years. Best results will be obtained if:

- The machine is operated with reasonable care.
- The machine is maintained regularly per the maintenance schedule provided in the User Manual.
- The machine is maintained with PowerBoss® supplied or equivalent parts.

All right side and left side references to the machine (except for engine) are determined by facing the direction of forward travel. The front of the engine or engine fan faces the front of the machine. Some hardware considered to be common or locally available has been omitted from the parts section to make this manual clear. Be sure to use equivalent hardware when replacement becomes necessary.

The Model and Serial Number of your machine is shown on the I.D. name plate. This information is needed when contacting Technical Support or when ordering parts. The I.D. plate is mounted on the left side wall of the operator seating area.

Example I.D Plate:

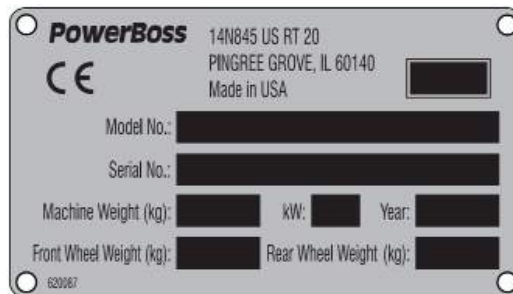

Parts may be ordered by phone, fax or e-mail from any PowerBoss® parts and service center. Before ordering parts or supplies, be sure to have your machine model number and serial number handy. For your convenience Fill out the data block below for future reference.

MACHINE DATA	
Fill out at installation	
Serial Number:	_____
Engine Serial Number:	_____
Sales Rep.:	_____
Date of Install:	_____

All information contained in this catalog is current at the time of printing. Minuteman International, Inc. reserves the right to make changes at any time without notice.

PowerBoss®, Minuteman International, Inc., Copyright 2014-2015, Printed in USA

TECHNICAL SPECIFICATIONS

Model: Nautilus Rider Scrubber/Sweeper
Model No.: PB45DSL(Diesel), PB45GAS(Gas), PB45LPG(LPG)

Nautilus CE Rider Scrubber/Sweeper
PB45DSLCE(Diesel), PB45LPGCE(LPG)

GENERAL MACHINE SPECIFICATIONS

- Length: 95.0 in (241.3 cm)
- Width with side scrub brush retracted: . . . 60.5 in (153.7 cm)
- Width with side scrub brush extended: . . . 65.5 in (166.4 cm)
- Height to lowest steering position: 60.5 in (153.7 cm)
- Height with overhead guard: 83.5 in (212.1 cm)
- Wheelbase: 47.75 in (121.3 cm)
- Front tires (molded): 16 in x 6 in
. (40 cm x 15 cm)
- Rear tires (press on): 18 in x 5 in
. (45 cm x 12 cm)
- Aisle width U-turn: 8 ft - 11.7 in (273.6 cm)
- Weight (Diesel engine) 4,047 lb (1836 kg)
- Weight (Gas & LPG engines) 4,027 lb (1826 kg)
- Maximum forward speed: 7.7 mph (12.4 km/h)
- Maximum reverse speed: 4.0 mph (6.4 km/h)
- Maximum climb angle (Traveling):. 10 deg. (17% grade)
- Maximum climb angle (Scrubbing):. 8 deg. (14% grade)

SCRUBBING SYSTEM

- Cleaning path (main brushes) 45 in (114 cm)
- Cleaning path (w/optional side brush) . . . 60 in (152 cm)
- Main brush diameter:. 12 in (30 cm)
- Main brush length:. 45 in (114 cm)
- Main brush speed:. 425 RPM
- Main brush force:. 200 lb - 400 lb
. (90 kg - 181 kg)
- Side scrub brush diameter: 16 in (40 cm)
- Side scrub brush speed: 200 RPM
- Solution Tank capacity: 105 gal (397 L)
- Recovery Tank capacity: 105 gal (397 L)
- Demister chamber capacity: 17 gal (64 L)
- (2)Debris trays, total capacity:. 2.1 ft³ (.059 m³)
- Vacuum fan speed: 11,500 RPM
- Vacuum water lift: 35 in (88 cm)

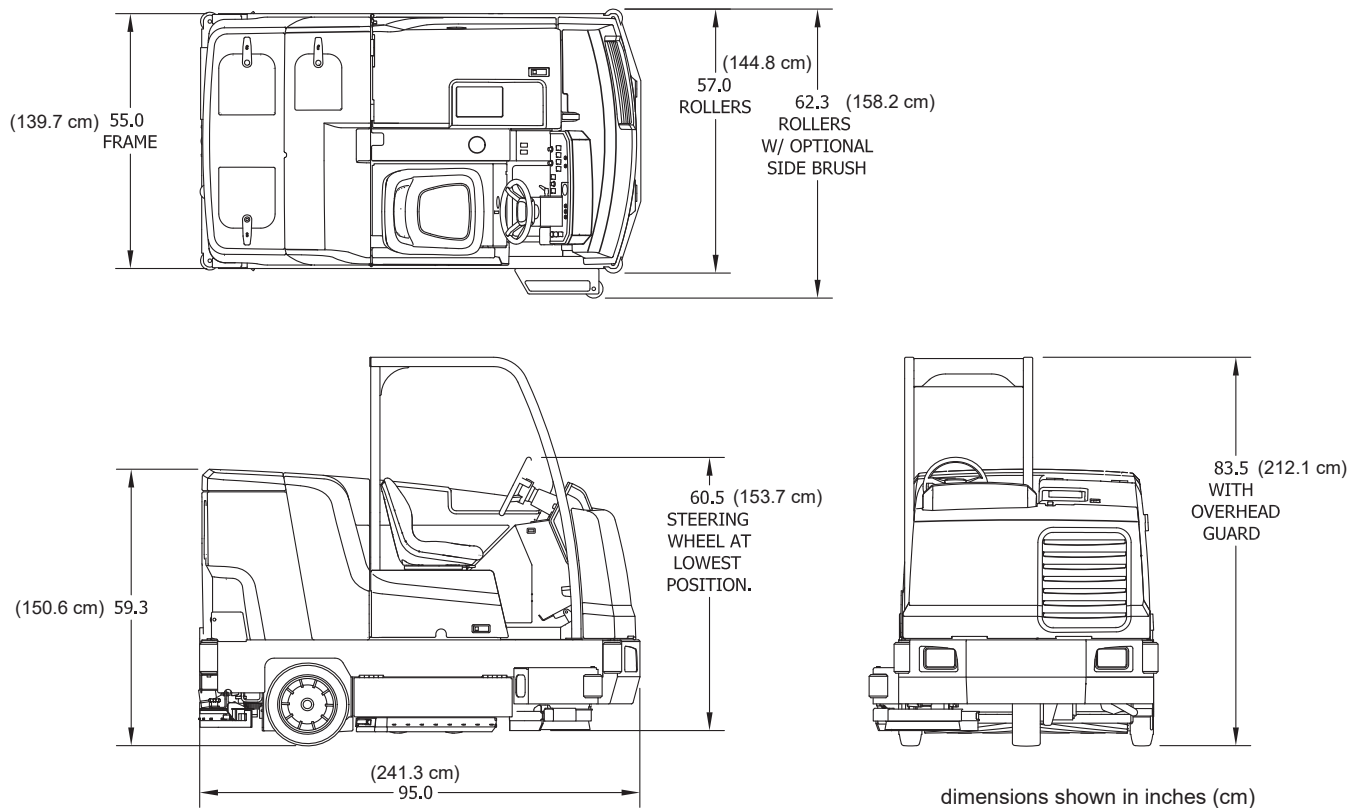

TABLE OF CONTENTS

PREFACE 2

TECHNICAL SPECIFICATIONS 4

 GENERAL MACHINE SPECIFICATIONS 4

 SCRUBBING SYSTEM 4

PARTS BREAKDOWN 8

 FRAME GROUP (730100) 8

 BRAKE GROUP (730101) 10

 REAR WHEEL GROUP (730105) 12

 FRONT WHEEL GROUP (730102) 13

 STEERING FORK GROUP (730103) 14

 CONSOLE GROUP (730152) 16

 STEERING COLUMN GROUP (730104) 18

 INSTRUMENT PANEL GROUP - DIESEL (730108) 20

 INSTRUMENT PANEL GROUP - GAS (730107) 22

 INSTRUMENT PANEL GROUP - LPG (730106) 24

 INSTRUMENTATION GROUP (730109) 26

 ELECTRICAL BOX GROUP - DIESEL (730156) 28

 DIRECTIONAL CONTROL GROUP (730110) 30

 PUMP LINKAGE GROUP (730111) 32

 SCRUB HEAD GROUP (730112) 34

 SCRUB BRUSH LIFT GROUP (730113) 36

 SCRUB BRUSH IDLER GROUP (730114) 38

 BRUSH DOOR GROUP (730115) 40

 SQUEEGEE LIFT GROUP (730119) 42

 SQUEEGEE LINKAGE GROUP (730158) 44

 SQUEEGEE GROUP (730118) 46

 SIDE SQUEEGEE GROUP - RH (730120) 48

 SIDE SQUEEGEE GROUP - LH (730157) 50

 SOLUTION TANK GROUP (730121) 52

 SOLUTION CONTROL GROUP (730123) 54

 RECOVERY TANK GROUP (730122) 56

 RECOVERY TANK DRAIN GROUP (730155) 58

 PLASTIC HOPPER GROUP (730173) 60

 HOPPER CRADLE GROUP (730174) 62

 REAR BUMPER GROUP (730125) 64

 BUMPER LIFT GROUP (730159) 66

 IMPELLER GROUP (730126) 68

 IMPELLER HYDRAULIC MANIFOLD GROUP (730172) 70

 HYDRAULIC RESERVOIR GROUP (730127) 72

 HYDRAULIC PUMP GROUP (730136) 74

HYDRAULIC VALVE GROUP (730137)	76
HYDRAULIC MANIFOLD COMPONENTS GROUP (730170)	78
ENGINE MOUNT GROUP - DIESEL (730128)	80
ENGINE MOUNT GROUP - GAS (730164)	82
ENGINE MOUNT GROUP - LPG (730163)	84
AIR CLEANER GROUP - DIESEL (730131)	86
AIR CLEANER GROUP - GAS (730129)	88
AIR CLEANER GROUP - LPG (730130)	90
RADIATOR GROUP (730132)	92
RADIATOR OVERFLOW BOTTLE GROUP (730133)	94
OIL COOLER GROUP (730134)	96
EXHAUST GROUP - DIESEL (730154)	98
EXHAUST GROUP - GAS / LP (730178)	100
FUEL TANK MOUNT GROUP - DIESEL (730140)	102
FUEL TANK MOUNT GROUP - GAS (730139)	104
LPG TANK MOUNT GROUP (730138)	106
FUEL LINE GROUP - DIESEL (730153)	108
FUEL COMPONENT GROUP - GAS (730141)	110
THROTTLE SOLENOID GROUP - DIESEL (730151)	112
BATTERY GROUP (730142)	114
FRONT COVER GROUP (730143)	116
TOP COVER GROUP (730144)	118
SIDE DOOR GROUP (730145)	120
SEAT DOOR GROUP (730146)	122
SEAT MOUNT GROUP (730147)	124
HYDRAULIC HOSE GROUP (730148)	126
HOSE CLAMP GROUP (730149)	128
DECAL GROUP (730150)	130
ELECTRICAL GROUP (730116)	132
BRUSH/BROOM GROUP (730175)	134
OPTIONS - PARTS BREAKDOWN	136
OPTION - SIDE BRUSH GROUP (730000)	136
OPTION - SIDE BRUSH LIFT GROUP (730001)	138
OPTION - SIDE BRUSH SOLUTION CONTROL GROUP (730002)	140
OPTION - SIDE BRUSH HYDRAULIC HOSE GROUP (730011)	142
OPTION - SIDE BRUSH SCRUB HEAD GROUP (730028)	144
OPTION - SIDE BRUSH STEERING COLUMN GROUP (730029)	145
OPTION - SSB HYDRAULIC MANIFOLD GROUP (730171)	146
OPTION - OVERHEAD GUARD GROUP (730003)	148
OPTION - STROBE LIGHT GROUP (ON OVERHEAD GUARD) (730004)	150
OPTION - ROTATING LIGHT GROUP (ON OVERHEAD GUARD) (730005)	152
OPTION - FLASHING LIGHT GROUP (ON OVERHEAD GUARD) (730006)	154

TABLE OF CONTENTS

OPTION - SUSPENSION SEAT GROUP (730007).....	156
OPTION - BACKUP ALARM GROUP (730008).....	158
OPTION - SEAT BELT (FOR SUSPENSION SEAT) GROUP (730009)	160
OPTION - SEAT BELT (FOR STANDARD SEAT) GROUP (730010).....	162
OPTION - STROBE LIGHT GROUP (ON SOLUTION TANK) (730012)	164
OPTION - ROTATING LIGHT GROUP (ON SOLUTION TANK) (730013).....	166
OPTION - FLASHING LIGHT GROUP (ON SOLUTION TANK) (730014).....	168
OPTION - CHEMICAL METERING GROUP (730015)	170
OPTION - FIRE EXTINGUISHER GROUP (730016)	172
OPTION - AUTO FILL GROUP (730017).....	174
OPTION - SPRAY AND VAC WAND TOOL GROUP (730020).....	176
OPTION - SPRAY AND VAC WAND HOSE GROUP (730021)	178
OPTION - SPRAY AND VAC WAND MOUNT GROUP (730022)	180
OPTION - SPRAY AND VAC WAND PUMP GROUP (730023)	182
OPTION - URETHANE SQUEEGEE BLADE GROUP (730024)	184
OPTION - URETHANE SIDE BRUSH SQUEEGEE GROUP (730025).....	186
OPTION - STAINLESS STEEL HOPPER GROUP (730027)	188
OPTION - SEAT SWITCH (730031)	190
OPTION - SIDE BROOM GROUP (730032)	192
OPTION - SIDE BROOM LIFT AND ADJUSTMENT GROUP (730033)	194
OPTION - SIDE BROOM HYDRAULIC HOSE GROUP (730034)	196
OPTION - SIDE BRUSH HYDRAULIC HOSE ROUTING (730038).....	198
OPTION - PRESSURE WASHER PUMP GROUP (730041-1).....	200
OPTION - PRESSURE WASHER HOSE AND WAND GROUP (730041-2)	202
OPTION - PRESSURE WASHER HYDRAULIC HOSE GROUP (730041-3)	204
OPTION - LOW LP INDICATOR GROUP (730042)	206
OPTION - REAR SQUEEGEE GUARD (730048)	208
OPTION - RESERVE LPG TANK GROUP (730160).....	210
OPTION - STROBE LIGHT GROUP W/CHEMICAL METERING (730166)	212
OPTION - ROTATING LIGHT GROUP W/CHEMICAL METERING (730167).....	214
OPTION - FLASHING LIGHT GROUP W/CHEMICAL METERING (730168)	216
OPTION - BACKUP ALARM GROUP - CM, RESERVE LPG IN (730169)	218
OPTION - DUST SUPPRESSION (731482).....	220
MISCELLANEOUS ADDITIONAL OPTIONS	222
LAYOUTS - ELECTRICAL/HYDRAULIC	224
ELECTRICAL SCHEMATIC LAYOUT	224
ELECTRICAL SCHEMATIC LAYOUT (POINT TO POINT WIRING).....	228
HYDRAULIC SYSTEM LAYOUT	232
HYDRAULIC SYSTEM LAYOUT WITH OPTIONAL SIDE SCRUB BRUSH.....	233
NOTES.....	234
WARRANTY.....	235

PARTS BREAKDOWN
FRAME GROUP (730100)

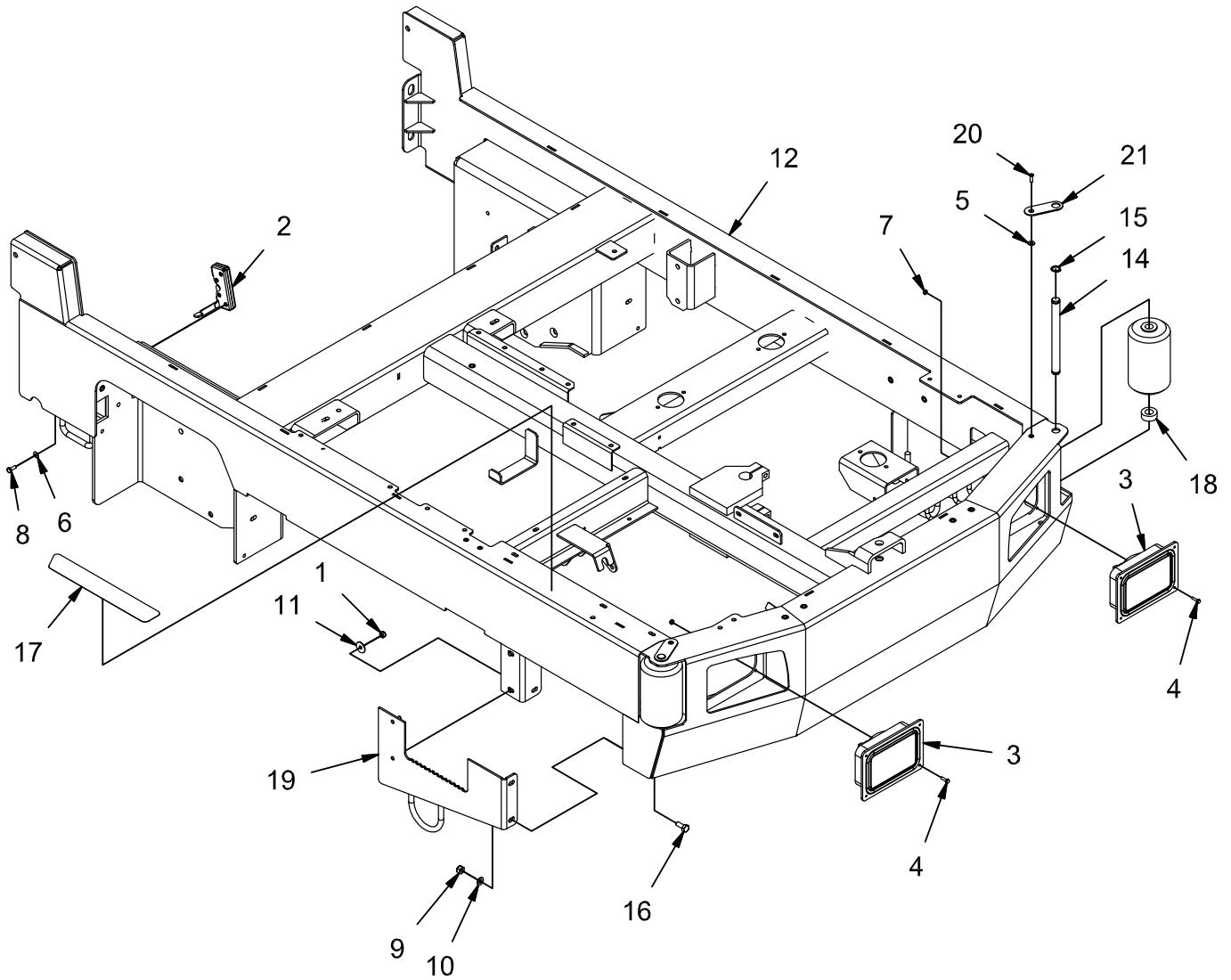

REV F

FRAME GROUP (730100)

Parts List 730100			
ITEM	PART NUMBER	QTY	DESCRIPTION
1	12040259	2	NUT, M8-1.25 ESN SS
2	3307247	1	LATCH, RH
3	3315839	2	HEADLIGHT 12V
4	3400044	8	SCR-HEX,#10-32 X 0.75 ZP
5	3400089	2	WASHER, 1/4 .625 X .281 X .063
6	3400383	4	WASHER, 1/4 BELLEVILLE
7	711350	8	NUT, 10-32, ESN
8	712562	4	SCREW, 1/4-20 X .75 HH SS
9	730339	2	NUT, M10-1.50 ESN SS
10	730344	2	WASHER, M10 SS
11	730526	2	WASHER, M8 FENDER SS
12	730550-1	1	ASSEMBLY, FRAME
13	730719	2	ROLLER
14	730876	2	PIN, ROLLER
15	730877	2	RETAINING RING, EXT, .750
16	730958	2	BOLT, M10-1.50 X 25 HH SS
17	730967	1	PAD, STEP
18	730975	2	SPACER, .813 B 1.50 OD .56 T
19	730978	1	ASSEMBLY, COVER
20	731382	2	SCREW, M6-1.00 X 20 FLAT SHCS ZP
21	731388	2	RETAINER, ROLLER PIN

BRAKE GROUP (730101)

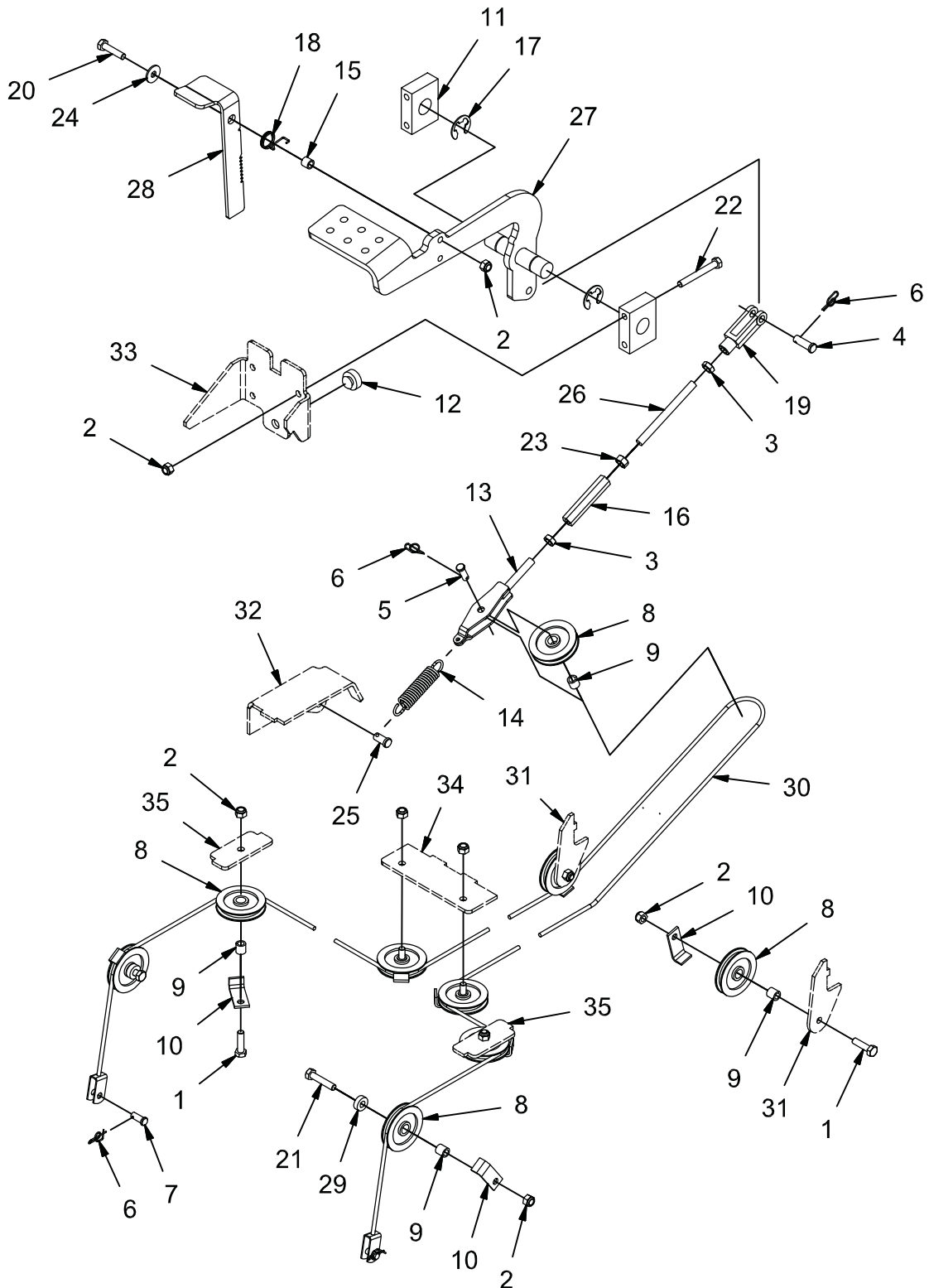

REV *

BRAKE GROUP (730101)

Parts List 730101			
ITEM	PART NUMBER	QTY	DESCRIPTION
1	11038254	6	BOLT, M8-125 X 30 HH
2	12040051	13	NUT, M8-1.25 ESN
3	3400075	2	NUT, HEX JAM 3/8-24
4	3400117	1	PIN, CLEVIS 3/8 X 1.125
5	3400118	1	PIN, CLEVIS, .313 X .88
6	3400125	4	RUE-RING, .375
7	450034	2	PIN, CLEVIS, .313 X .75
8	600113	9	PULLEY, .50 B, 2.00 D, .44 T
9	600114	9	SPACER, .328 B .498 OD .500 T
10	600115	8	RETAINER, CABLE
11	600116	2	BLOCK, BRAKE PIVOT
12	600117	1	BUMPER, 1.00 X .339 T
13	600121	1	CLEVIS, BRAKE PULLEY
14	600127	1	SPRING, EXT, .105 W .75 OD 3.50 L
15	600315	1	SPACER, .344 B .485 OD .425 T
16	600338	1	TURNBUCKLE, .375
17	600570	2	E-RING, .88
18	600809	1	SPRING, TORSION
19	600813	1	CLEVIS, 3/8-24
20	600918	1	BOLT, M8-125 X 35 HH
21	600919	2	BOLT, M8-1.25 X 40 HH
22	600921	4	BOLT, M8-1.25 X 65 HH
23	600938	1	NUT, 3/8-24 LH
24	600940	1	WASHER, M8 FENDER
25	711679	1	PIN, CLEVIS, .375 X .75
26	730369	1	ROD, BRAKE ADJ
27	730370	1	WELDMENT, BRAKE PEDAL
28	730372	1	PEDAL, PARKING BRAKE
29	730374	2	SPACER, .344 ID .75 OD .25 T
30	730375	1	CABLE, BRAKE
31	REF.	-	FRAME
32	REF.	-	FRAME
33	REF.	-	CONSOLE
34	REF.	-	FRAME
35	REF.	-	FRAME

REAR WHEEL GROUP (730105)

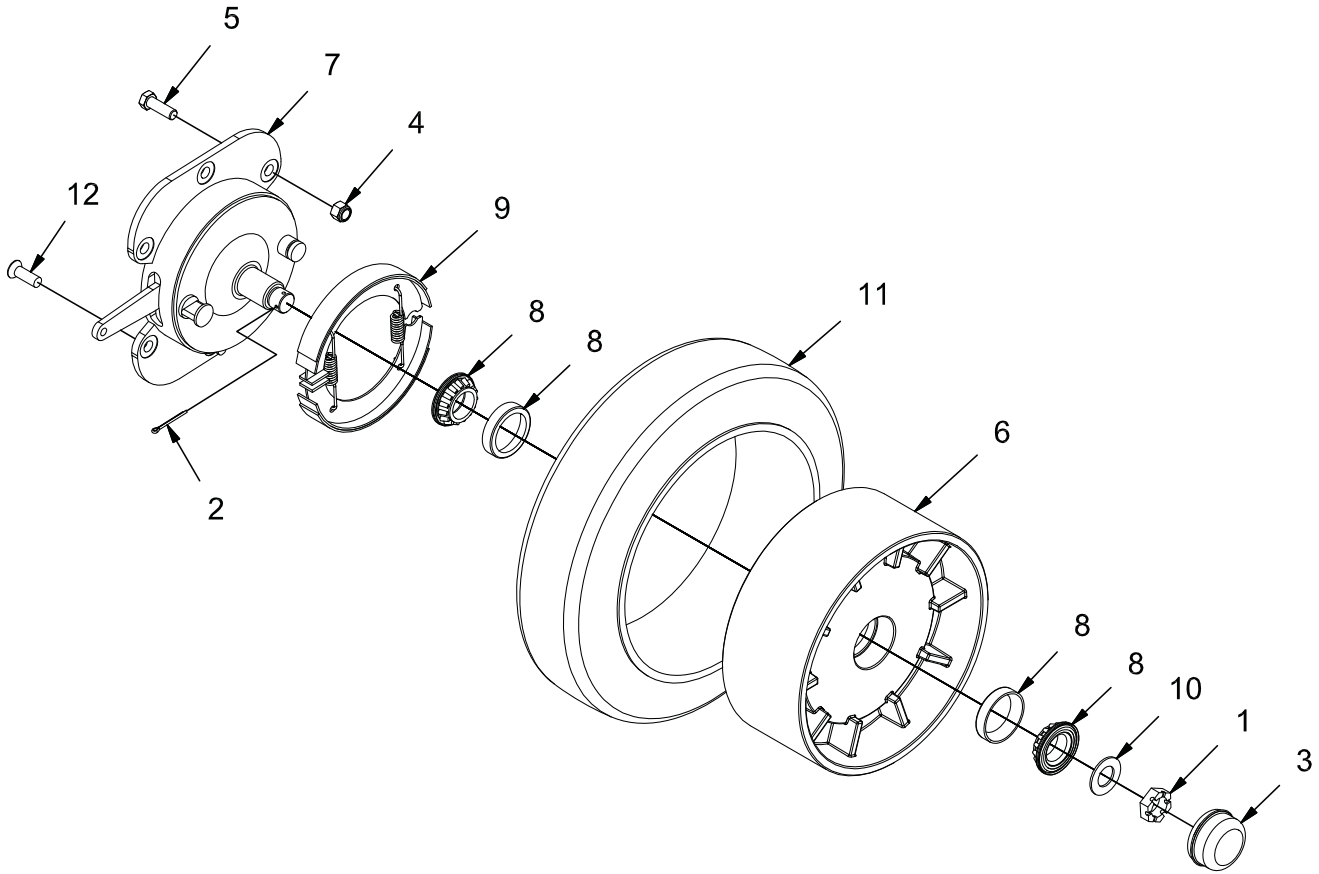

Parts List 730105			
ITEM	PART NUMBER	QTY	DESCRIPTION
1	3400223	2	NUT, 1-20 SLOTTED ZP
2	380-632-20	2	PIN, COTTER .125 X 1.50 ZP
3	383250	2	GREASE CAP
4	711376	12	NUT, FIBER INSERT 1/2-13
5	712047	6	SCREW, 1/2-13 X 1.50 HHC
6	730314	2	RIM, 18"
7	730316	2	ASSEMBLY, BRAKE-AXLE
8	730353	4	BEARING SET, 1.38 BORE CUP AND CONE
9	730357	-	BRAKE SHOE REPLACEMENT KIT
10	730358	2	SPACER, 1.03 B 1.88 OD .105 T
11	730359	2	TIRE, PRESS ON, 18 X 5
12	731100	6	SCREW, .50-13 x 1.50 FHCS ZP

REV *

FRONT WHEEL GROUP (730102)

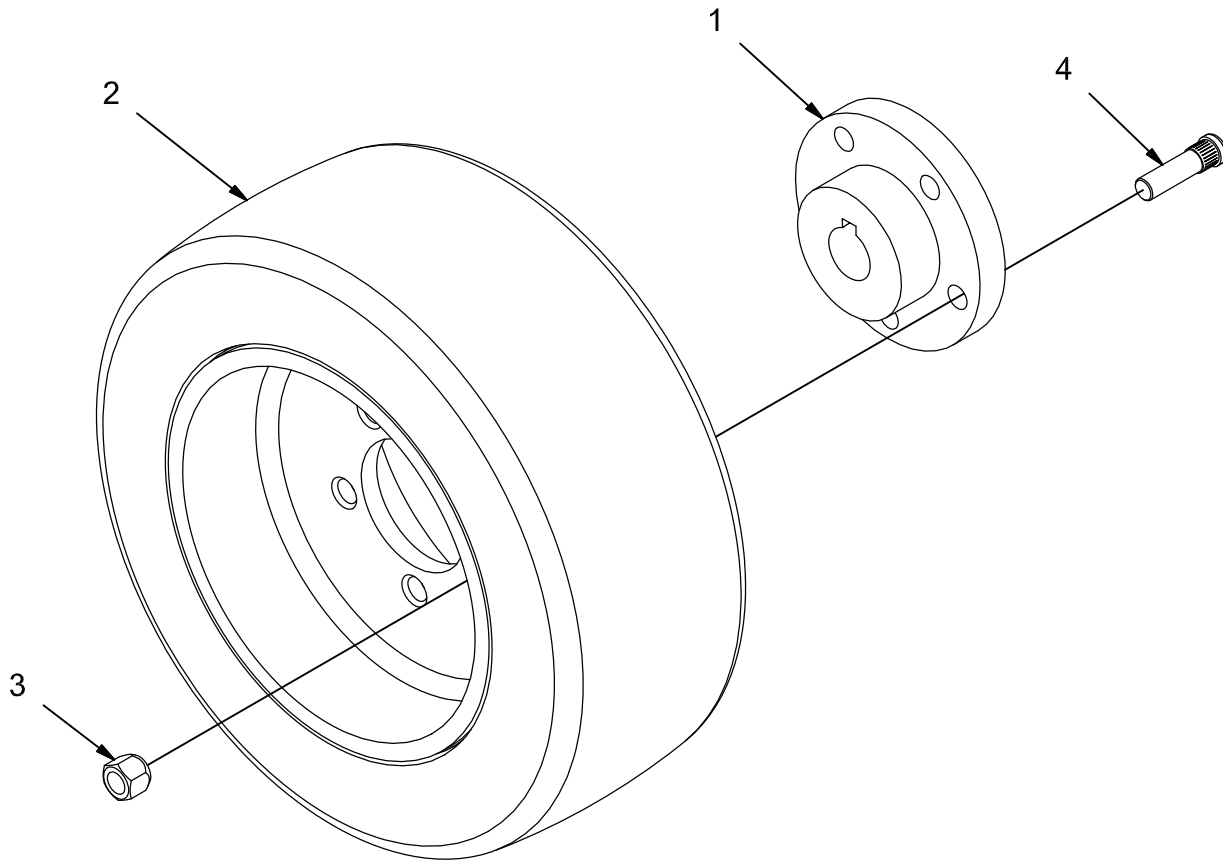

Parts List 730102			
ITEM	PART NUMBER	QTY	DESCRIPTION
1	3316056	1	HUB, REAR WHEEL PNTD FULL
2	3316330	1	ASSEMBLY, TIRE AND RIM 16" PRESS-ON
3	3316057	5	NUT, LUG, 9/16-18
4	713526	5	STUD, WHEEL

REV A

STEERING FORK GROUP (730103)

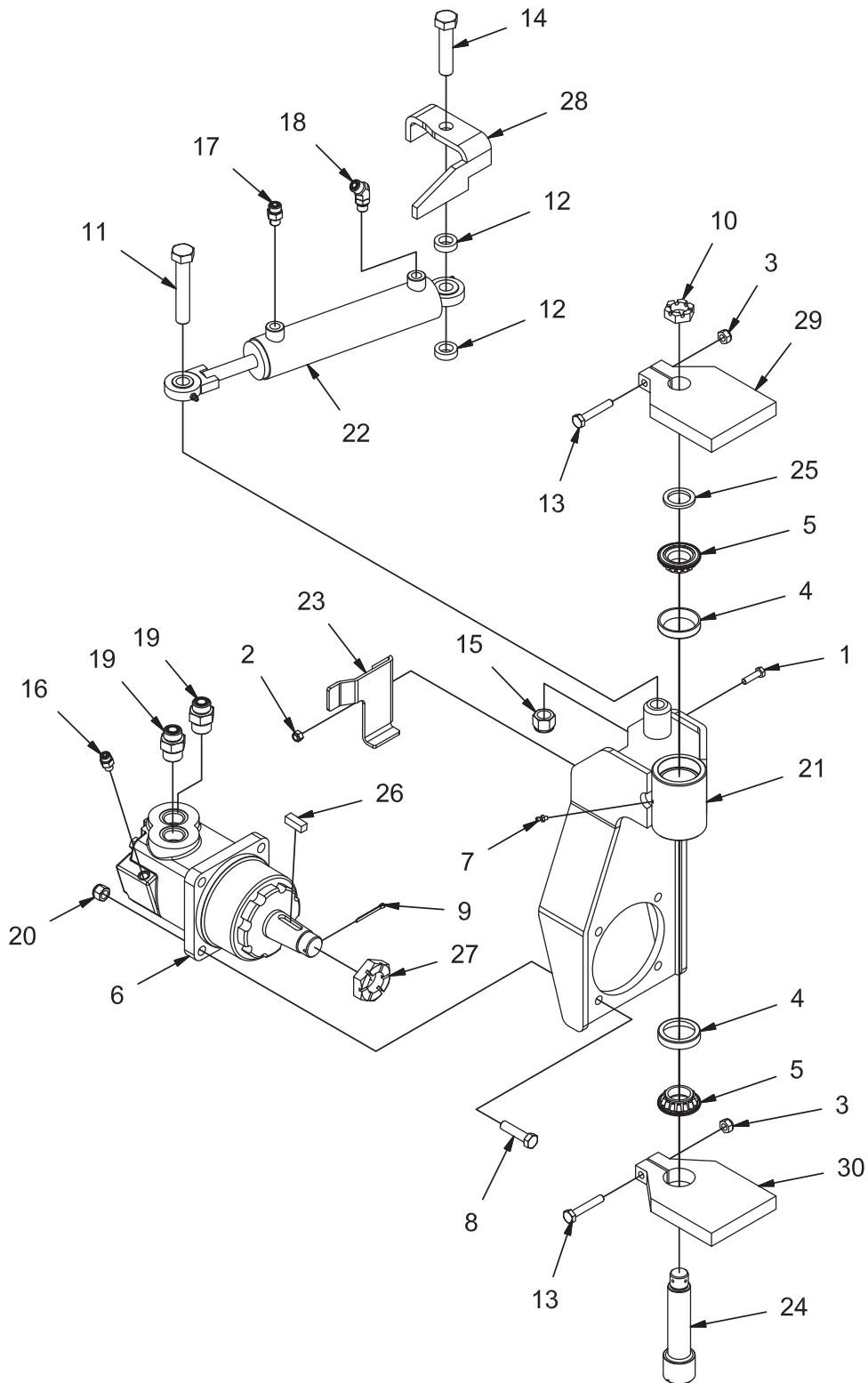

REV B

STEERING FORK GROUP (730103)

Parts List 730103			
ITEM	PART NUMBER	QTY	DESCRIPTION
1	11038254	1	BOLT, M8-125 X 30 HH
2	12040051	1	NUT, M8-1.25 ESN
3	12040069	2	NUT, M10-1.50 ESN
4	3300470	2	BEARING, PIVOT BEARING - CUP
5	3300471	2	BEARING - CONE W/SEAL
6	3305108	1	MOTOR, HYD. WHEEL
7	3400012	3	GREASE ZIRK
8	3400020	4	BOLT, 1/2-13 X 2.00 HH
9	3400122	1	COTTERPIN .125 X 2.00
10	3400223	1	NUT, 1-20 SLOTTED ZP
11	731426	1	BOLT, 3/4-10 X 4.25 HH STL ZP
12	731427	2	SPACER, .766 B 1.25 OD .375 T
13	600925	2	BOLT, M10-1.50 X 60 HH
14	600932	1	BOLT, 3/4-10 X 3.25 HH
15	620059	1	NUT, 3/4-10 FIBER INSERT STL ZP
16	675508	1	FITTING, STR, 4 ORFS - 4-SAE
17	675515	1	FITTING, STR, 6 ORFS - 6 SAE
18	675552	1	FITTING, 45, 6 ORFS - 6 SAE
19	675578	2	FTG, STR, -12 ORFS TO -12 SAE
20	711376	4	NUT, FIBER INSERT 1/2-13
21	730300	1	WELDMENT, STEERING FORK
22	730307	1	CYLINDER, STEERING
23	730312	1	RETAINER, HOSE
24	730351	1	PIN, PIVOT
25	730352	1	SPACER, 1.255 B 1.75 OD .166 T
26	PART OF 3305108	1	KEY .44 SQ X 1.25
27	PART OF 3305108	1	NUT 1.25-18
28	REF.	-	FRAME
29	REF.	-	FRAME
30	REF.	-	FRAME

CONSOLE GROUP (730152)

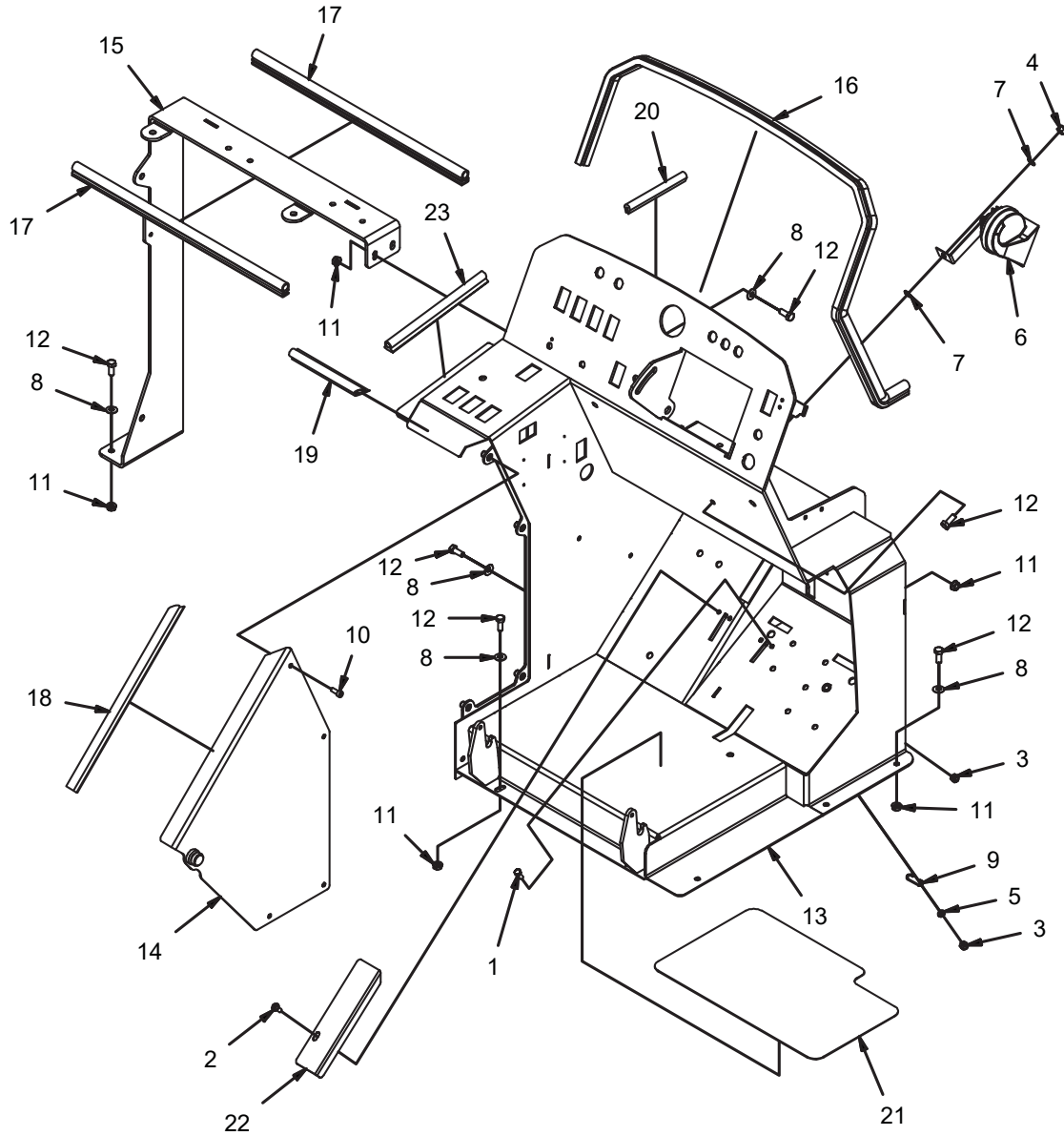

'G

REV F

CONSOLE GROUP (730152)

ITEM	PART NUMBER	QTY	DESCRIPTION
1	11038072	2	BOLT, M6-1.00 X 16 HH
2	11177060	1	SCREW, M6-1.00 X 16 BHCS W/FLANGE S
3	12040044	3	NUT, M6-1.00 ESN
4	12040259	1	NUT, M8-1.25 ESN SS
5	12310033	2	WASHER, M6
6	3300379	1	HORN, 12V
7	3400273	2	WASHER, STAR, .31, INT. ZP
8	3400384	11	WASHER, 5/16 BELLEVILLE
9	600125	1	CATCH, PARKING BRAKE
10	600912	4	BOLT, M6-1.00 X 16 SHCS
11	600934	11	NUT, M8-1.25 FLNG
12	717024	12	BOLT, M8-1.25 X 20 HH
13	730376-1	1	ASSEMBLY, CONSOLE
14	730396	1	WELDMENT, CONSOLE COVER
15	730401	1	WELDMENT, COVER FRAME
16	730536	1	SEAL, BULB, 50.50 LG
17	730537	2	SEAL, BULB, 19.38 LG
18	730538	1	SEAL, BULB, 14.00 LG
19	730539	1	SEAL, BULB, 6.63 LG
20	730543	1	EDGING, 1/8 X 5.25"
21	730988	1	PAD, FLOOR
22	731008	1	ANGLE, COVER
23	731162	1	SEAL, BULB, 8.88 LG

STEERING COLUMN GROUP (730104)

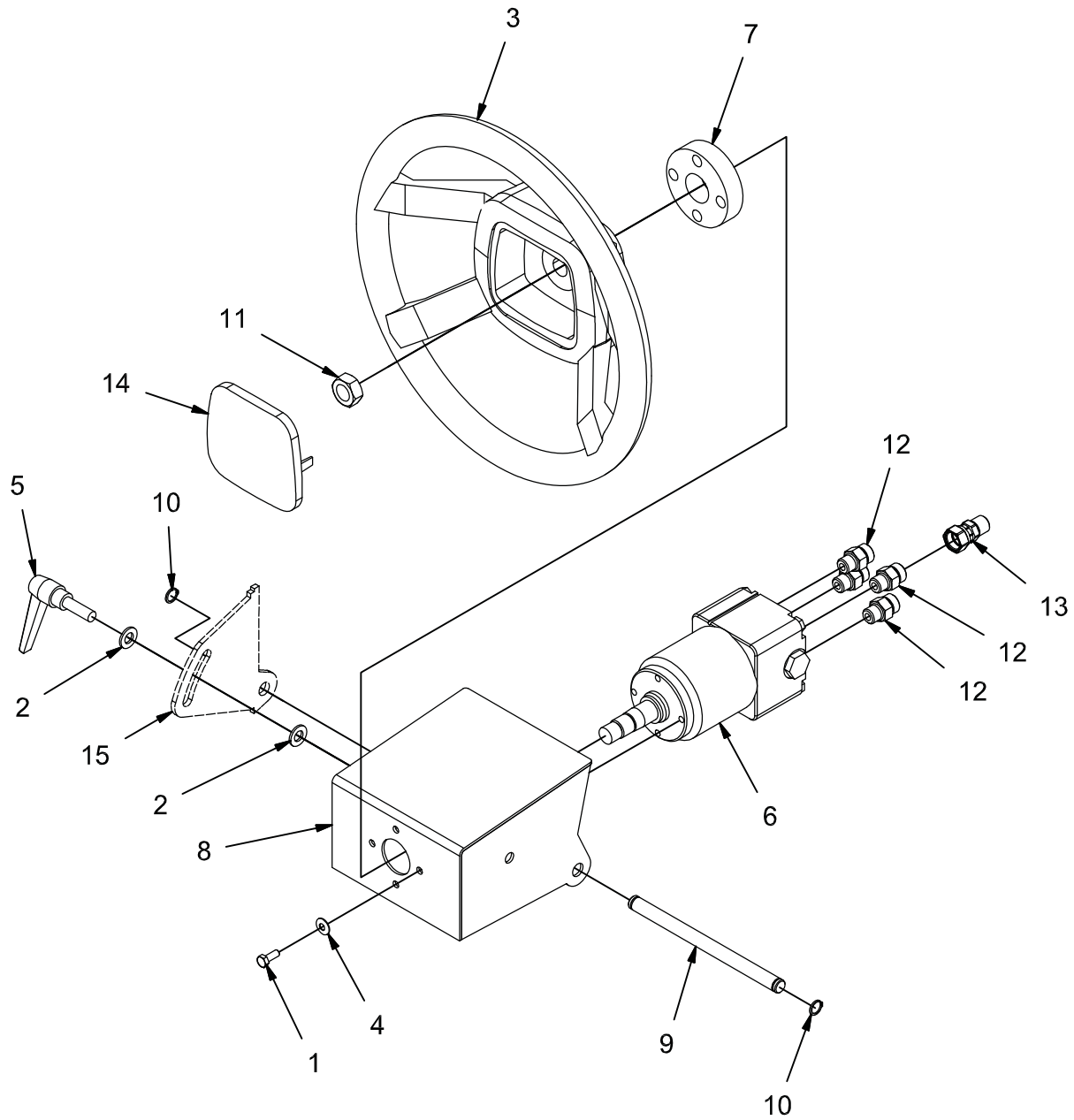

REV *

STEERING COLUMN GROUP (730104)

Parts List			
ITEM	PART NUMBER	QTY	DESCRIPTION
1	11038072	4	BOLT, M6-1.00 X 16 HH
2	12310058	2	WASHER, M10
3	3338215	1	STEERING WHEEL
4	3400383	4	WASHER, 1/4 BELLEVILLE
5	600260	1	KNOB, LEVER
6	600368	1	STEERING UNIT
7	600389	1	STEERING RING
8	600465	1	WELDMENT, STEERING MNT
9	600516	1	SHAFT, ROLLER
10	600569	2	RETAINING RING, EXT .50 HD
11	620057	1	NUT, JAM, M16-1.50 STL ZP
12	675515	4	FITTING, STR, 6 ORFS - 6 SAE
13	675600	1	FTG - .094 ORIFICE ADAPTER -6 ORFS TO -6 ORFS
14	PART OF 3338215	1	COVER, STEERING WHEEL
15	REF	1	FRAME

INSTRUMENT PANEL GROUP - DIESEL (730108)

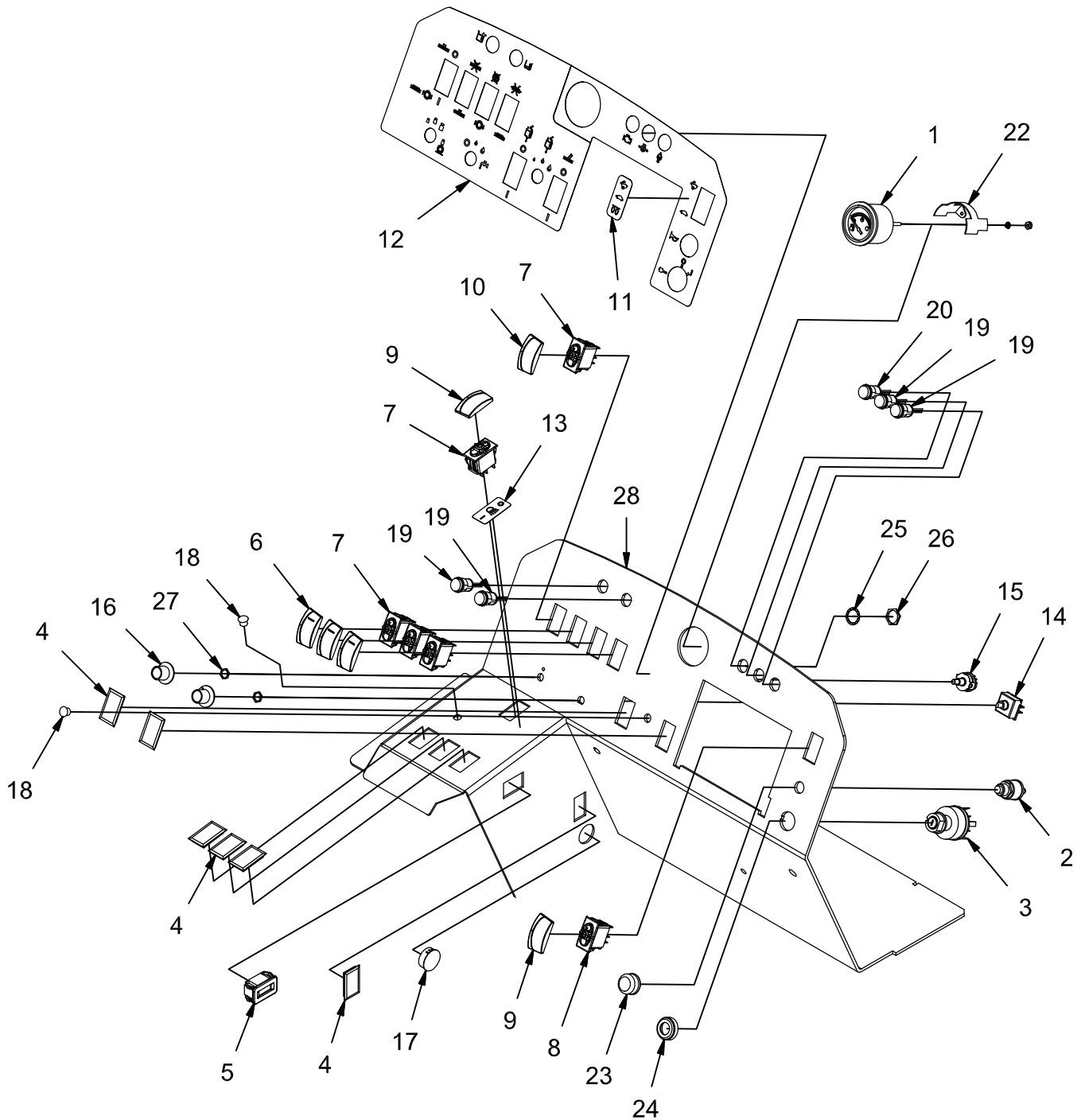

REV G

INSTRUMENT PANEL GROUP - DIESEL (730108)

Parts List 730108			
ITEM	PART NUMBER	QTY	DESCRIPTION
1	3300382	1	GAUGE, FUEL
2	3300441	1	SWITCH, MOMENTARY
3	3316100	1	KEYSWITCH
4	3323529	6	COVER
5	3336094	1	HOUR METER
6	3342273	3	SWITCH COVER - BLACK, CLEAR LENS
7	3342705	5	SWITCH, DPST
8	3343912	1	SWITCH, DPDT
9	3344038	2	SWITCH CAP
10	3344039	1	SWITCH CAP. GREEN
11	715956	1	DECAL, DIESEL IGN
12	715957	1	DECAL, INST PANEL
13	715973	1	DECAL, LIGHTS
14	730850	1	SWITCH, ROTARY, 3-WAY
15	730989-1	1	SWITCH, ROTARY 3-POS
16	731187	2	KNOB
17	731393	1	HOLE PLUG, 1-1/8
18	742749	2	PLUG, BLACK PLASTIC
19	748995	4	LIGHT ASSY, INDICATOR RED - LED
20	748996	1	LIGHT ASSY, INDICATOR AMBER - LED
21	748998	1	HARNESS, FUEL GAUGE
22	PART OF 3300382	1	RETAINER, GAUGE
23	PART OF 3300441	1	CAP, SWITCH
24	PART OF 3316100	1	NUT, KEYSWITCH
25	PART OF LED	5	LOCKWASHER
26	PART OF LED	5	NUT
27	PART OF ROTARY SWITCH	2	NUT
28	REF	-	CONSOLE
-	3301345-1	1	WIRE ASSY, LIGHT GAUGE

INSTRUMENT PANEL GROUP - GAS (730107)

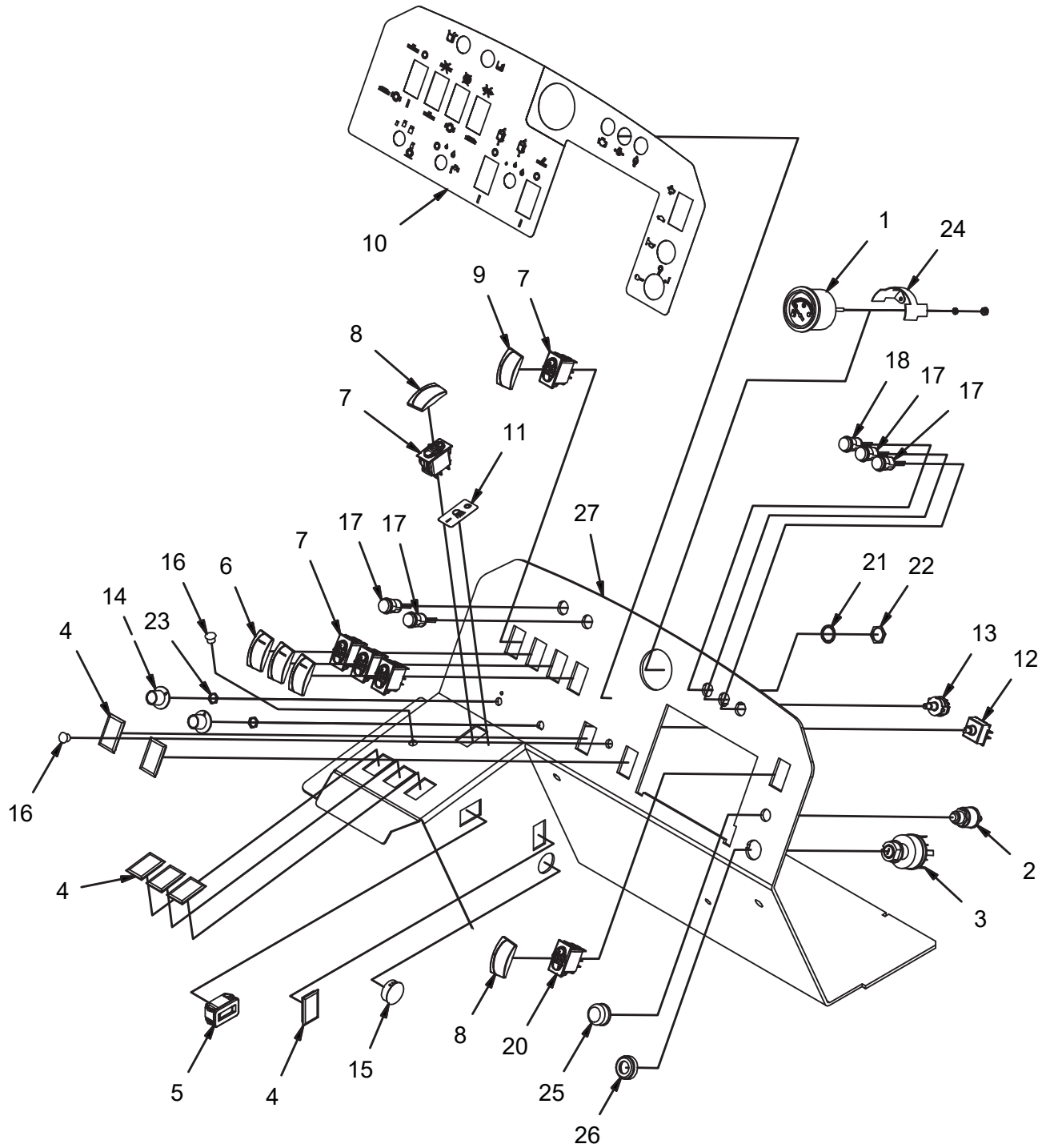

REV H

INSTRUMENT PANEL GROUP - GAS (730107)

Parts List 730107			
ITEM	PART NUMBER	QTY	DESCRIPTION
1	3300382	1	GAUGE, FUEL
2	3300441	1	SWITCH, MOMENTARY
3	3316100	1	KEYSWITCH
4	3323529	6	COVER
5	3336094	1	HOUR METER
6	3342273	3	SWITCH COVER - BLACK, CLEAR LENS
7	3342705	5	SWITCH, DPST
8	3344038	2	SWITCH CAP
9	3344039	1	SWITCH CAP. GREEN
10	715957	1	DECAL, INST PANEL
11	715973	1	DECAL, LIGHTS
12	730850	1	SWITCH, ROTARY, 3-WAY
13	730989-1	1	SWITCH, ROTARY 3-POS
14	731187	2	KNOB
15	731393	1	HOLE PLUG, 1-1/8
16	742749	2	PLUG, BLACK PLASTIC
17	748995	4	LIGHT ASSY, INDICATOR RED - LED
18	748996	1	LIGHT ASSY, INDICATOR AMBER - LED
19	748998	1	HARNESS, FUEL GAUGE
20	3342703	1	SWITCH, DPDT
21	PART OF LED	5	LOCKWASHER
22	PART OF LED	5	NUT
23	PART OF ROTARY SWITCH	2	NUT
24	PART OF 3300382	1	RETAINER, GAUGE
25	PART OF 3300441	1	CAP, SWITCH
26	PART OF 3316100	1	NUT, KEYSWITCH
27	REF	-	CONSOLE
-	3301345-1	1	WIRE ASSY, LIGHT GAUGE

INSTRUMENT PANEL GROUP - LPG (730106)

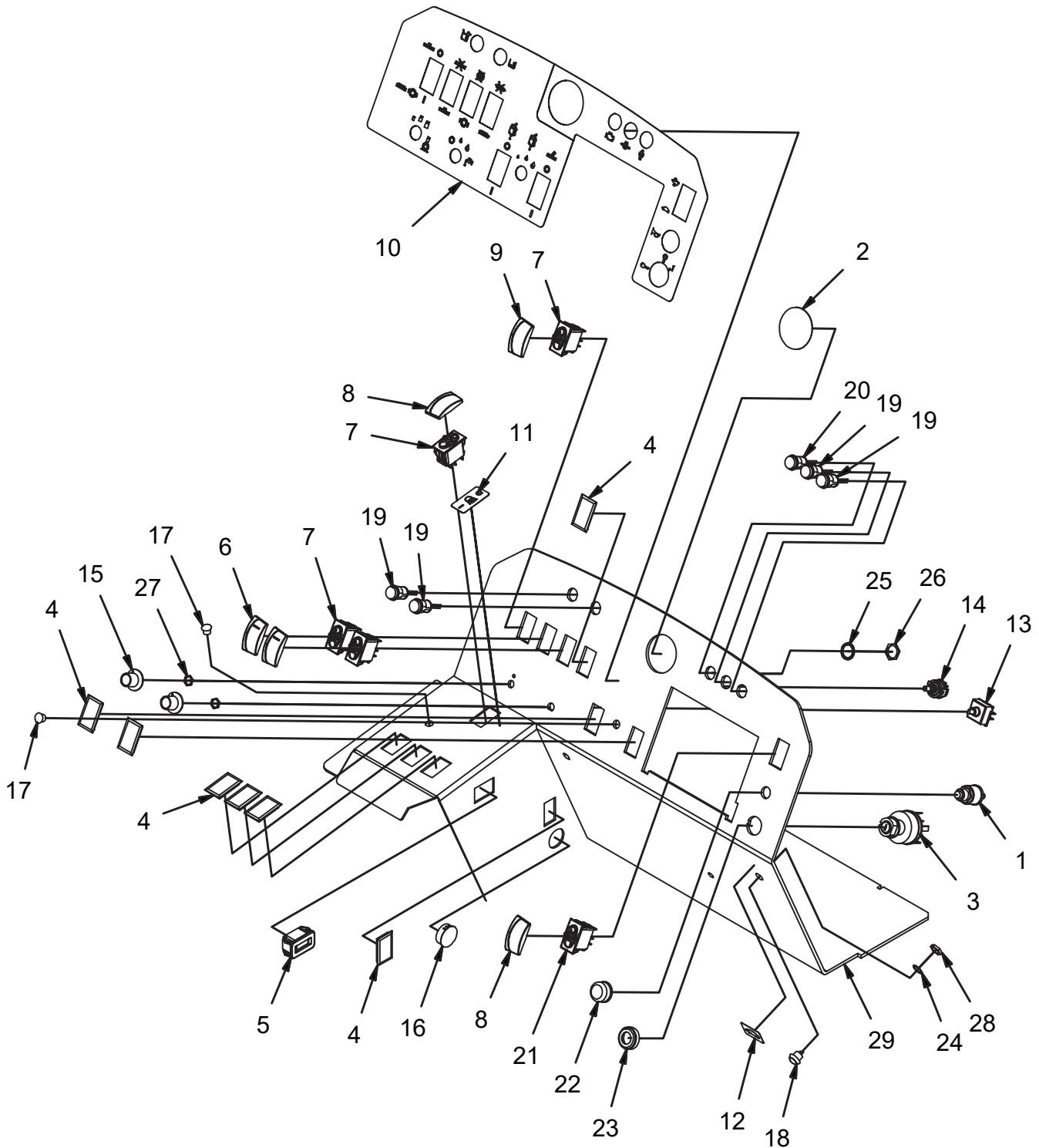

REV F

INSTRUMENT PANEL GROUP - LPG (730106)

Parts List 730106			
ITEM	PART NUMBER	QTY	DESCRIPTION
1	3300441	1	SWITCH, MOMENTARY
2	3301822	1	PLUG, PLASTIC, 2.00
3	3316100	1	KEYSWITCH
4	3323529	7	COVER
5	3336094	1	HOUR METER
6	3342273	2	SWITCH COVER - BLACK, CLEAR LENS
7	3342705	4	SWITCH, DPST
8	3344038	2	SWITCH CAP
9	3344039	1	SWITCH CAP. GREEN
10	715957	1	DECAL, INST PANEL
11	715973	1	DECAL, LIGHTS
12	715974	1	DECAL, IDLE
13	730850	1	SWITCH, ROTARY, 3-WAY
14	730989-1	1	SWITCH, ROTARY 3-POS
15	731187	2	KNOB
16	731393	1	HOLE PLUG, 1-1/8
17	742749	2	PLUG, BLACK PLASTIC
18	748791-1	1	WIRE ASSY, SWITCH
19	748995	4	LIGHT ASSY, INDICATOR RED - LED
20	748996	1	LIGHT ASSY, INDICATOR AMBER - LED
21	3342703	1	SWITCH, DPDT
22	PART OF 3300441	1	CAP, SWITCH
23	PART OF 3316100	1	NUT, KEYSWITCH
24	PART OF 748791-1	1	WASHER
25	PART OF LED	5	LOCK WASHER
26	PART OF LED	5	NUT
27	PART OF ROTARY SWITCH	2	NUT
28	PART OF 748791-1	1	NUT
29	REF	-	CONSOLE

INSTRUMENTATION GROUP (730109)

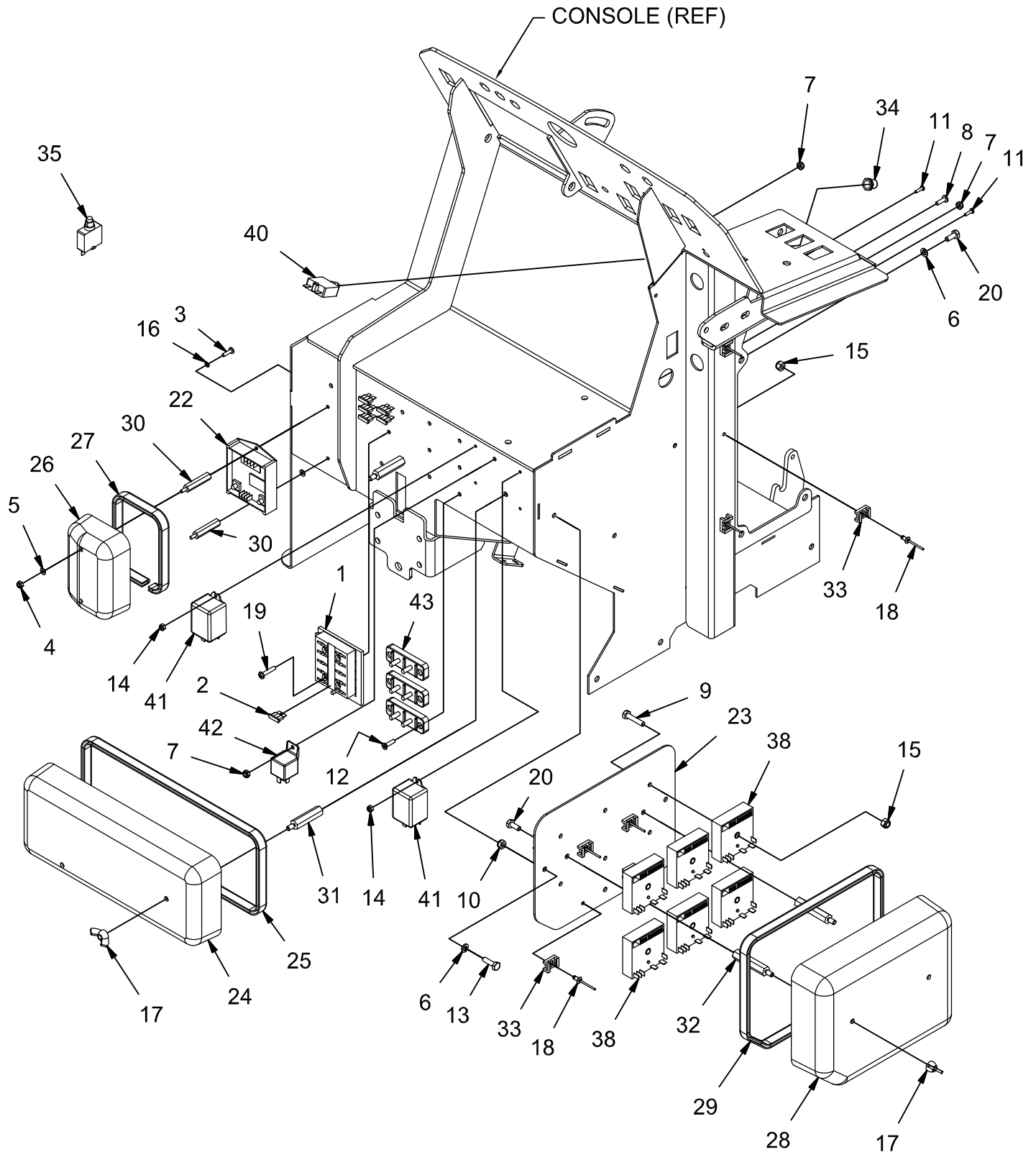

REV F

INSTRUMENTATION GROUP (730109)

Parts List - INSTRUMENTATION GROUP			
ITEM	PART NUMBER	QTY	DESCRIPTION
1	3322599	1	FUSE BLOCK
2	3322601	6	FUSE, 15A
3	3400045	2	SCREW, #8-32 X .625 PAN HD ZP
4	3400082	2	NUT, FIBER INSERT #8-32
5	3400096	2	FLATWASHER, #8
6	3400103	5	LOCK WASHER, 1/4 HS MED
7	3400172	9	NUT, 10-32 ESN
8	3400204	1	SCREW, #10-32 X .625 PAN HD ZP
9	3400227	6	SCREW, 1/4-20 X 1.25 HH ZP
10	3401021	3	NUT, LOW HEIGHT 1/4-20 ESN
11	710204	4	SCREW, #6-32 X .500 PAN HD ZP
12	710556	6	SCREW, FHMS, 10-32 X .75 ZP
13	711206	3	BLT - HH 1/4-20 X .87 STL ZINC
14	711371	4	NUT, #6-32 ESN ZP
15	711373	9	NUT, FIBER INSERT 1/4-20
16	711542	2	WASHER, HELICAL, #8 ZP
17	711563	4	WING NUT, 1/4-20, NYLON
18	711903	7	RIVET, BLIND, .19 D X .126 - .250 GRIP ALU
19	712546	2	SCREW, #10-32 X 1.00 PAN HD ZP
20	713001	4	SCREW, 1/4-20 X .625 HHC
21	731125	-	PROP VALVE DRIVER (PART OF 731125-1)
22	731125-1	1	ASSEMBLY, PROPORTIONAL VALVE DRIVER
23	731191	1	PLATE, TIMER
24	731227	1	COVER, FUSE PANEL
25	731228	1	SEAL, FUSE COVER
26	731229	1	COVER, CONTROLLER
27	731230	1	SEAL, CONTROLLER
28	731231	1	COVER, TIMER
29	731232	1	SEAL, TIMER COVER
30	731233	2	STANDOFF, PANEL, #8-32 X 1.75
31	731234	2	STANDOFF, PANEL, 1/4-20 X 2.00
32	731236	2	STANDOFF, PANEL, 1/4-20 X 2.38
33	731258	7	MOUNT, CABLE TIE
34	742748	1	BOOT, CIRCUIT BREAKER
35	746006	1	CIRCUIT BREAKER, 3A (ATTACHED TO HARNESS)
36	748339	-	HANESS, WIRE ASSY (PART OF 748430-1)
37	748430	-	TIMER (PART OF 748430-1)
38	748430-1	6	ASSEMBLY, TIMER
39	748431	-	HARNESS, WIRE ASSY (PART OF 731125-1)
40	748904	1	CIRCUIT BREAKER, 40A
41	748961	2	RELAY, DPDT, 12VDC, 35A
42	90264672	1	RELAY, SPDT, 12VDC, 30A
43	90286238	3	TERMINAL BLOCK

ELECTRICAL BOX GROUP - DIESEL (730156)

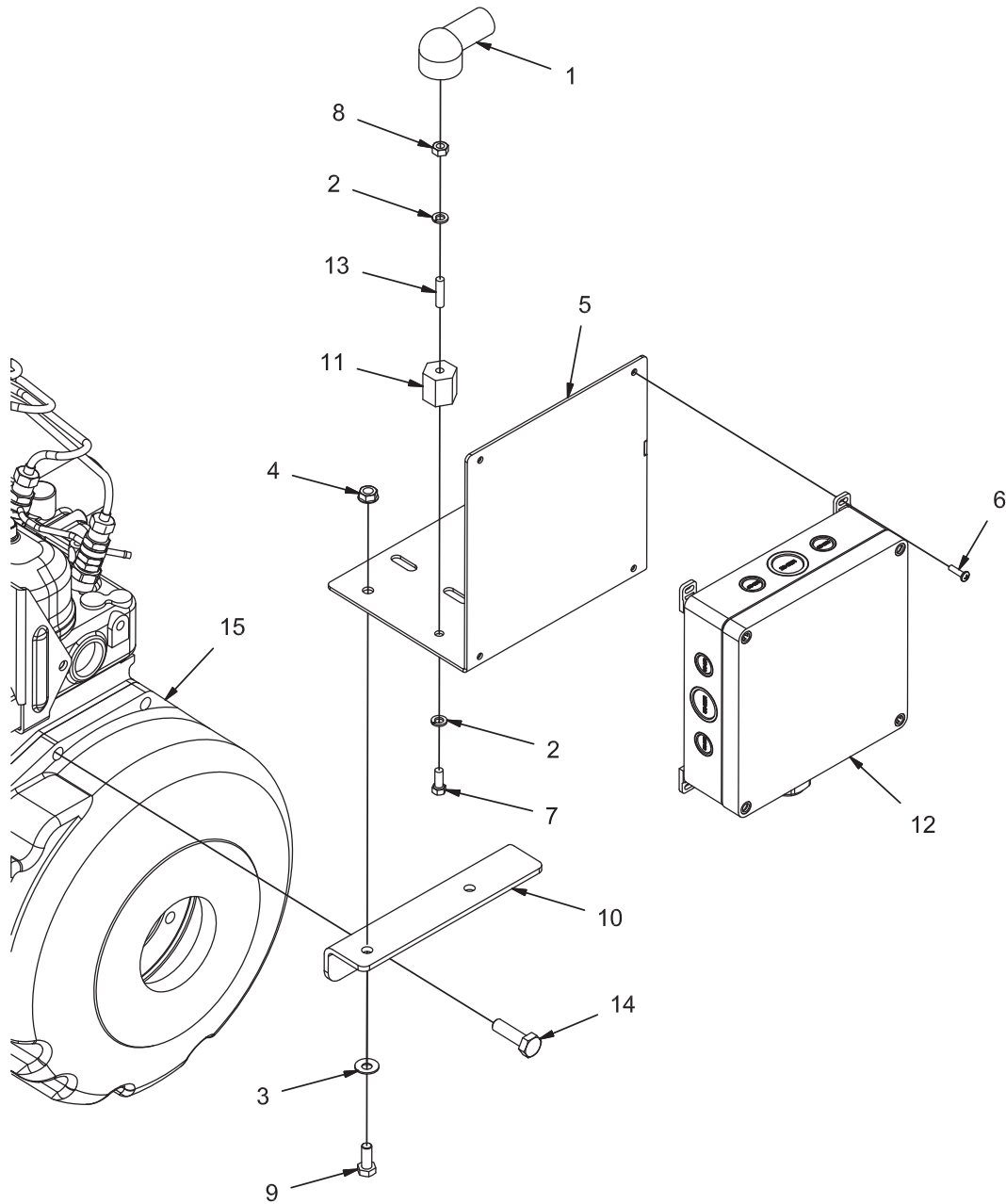

REV B

ELECTRICAL BOX GROUP - DIESEL (730156)

Parts List - 730156			
ITEM	PART NUMBER	QTY	DESCRIPTION
1	3342931	1	BOOT
2	3400103	2	LOCK WASHER, 1/4 HS MED
3	3400384	2	WASHER, 5/16 BELLEVILLE
4	600934	2	NUT, M8-1.25 FLNG
5	690042	1	BRACKET, DSL CNTL BOX
6	710330	4	SCR, 8-32 X 5/8 ZP STL
7	711203	1	BOLT, 1/4-20 X .625
8	711316	1	NUT, HEX 1/4-20 ZINC PL
9	717024	2	BOLT, M8-1.25 X 20 HH
10	730532	1	ANGLE, MOUNT
11	740132	1	PLASTIC INSULATOR
12	748769	1	DIESEL CNTL BOX
13	833638	1	1/4-20 STUD, BRASS
14	REF.	-	BOLT
15	REF.	-	DIESEL ENGINE
-	748909	1	STARTER CABLE
-	748950	1	WIRE ASSY, OIL PRESSURE SWITCH
-	748951	1	WIRE ASSY, WATER TEMP SWITCH

DIRECTIONAL CONTROL GROUP (730110)

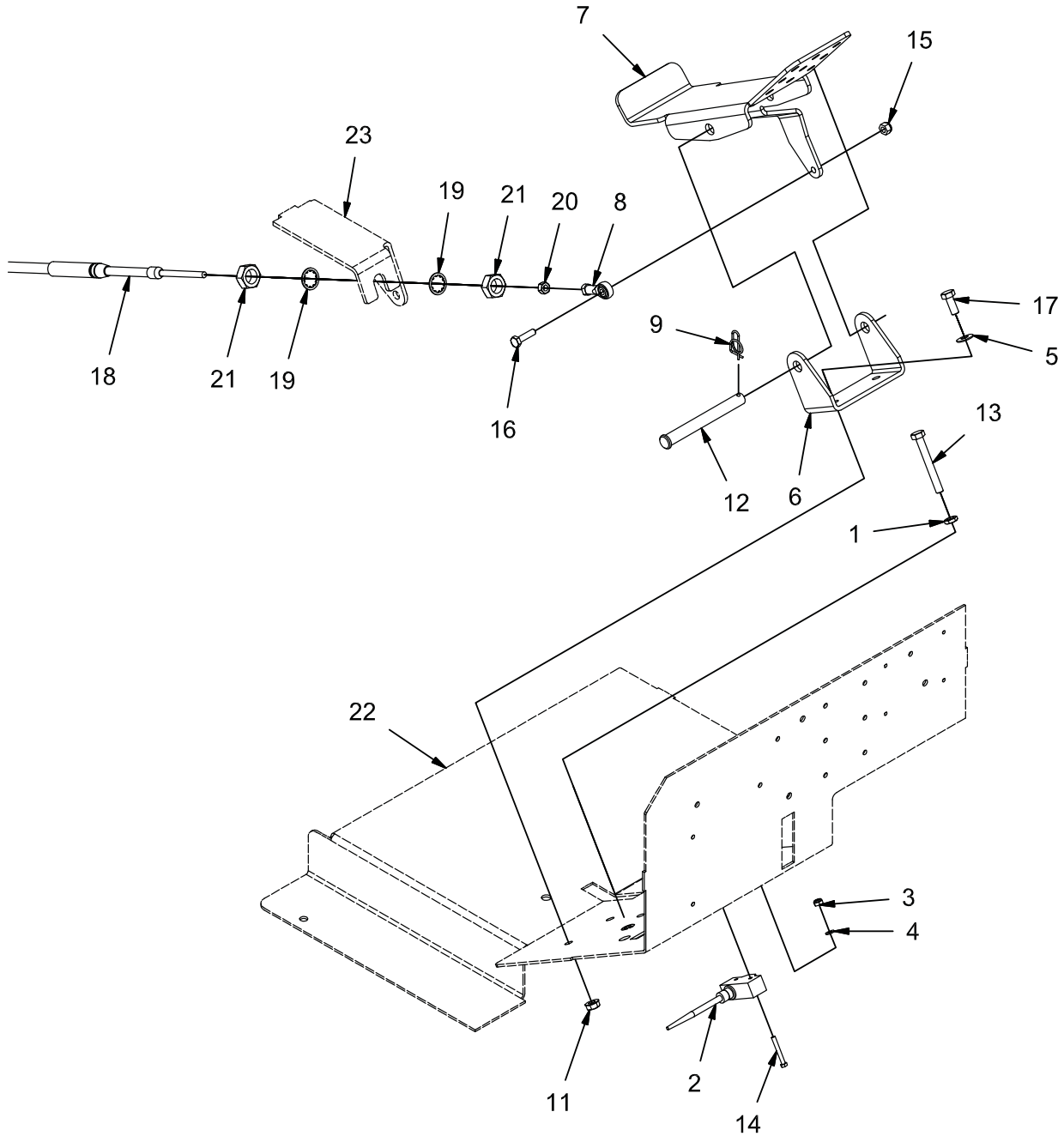

REV C

DIRECTIONAL CONTROL GROUP (730110)

Parts List 730110			
ITEM	PART NUMBER	QTY	DESCRIPTION
1	12012019	1	NUT, M8-1.25 JAM
2	3342546-1	1	HARNESS, SWITCH, WHISKER
3	3400082	2	NUT, FIBER INSERT #8-32
4	3400096	2	FLATWASHER, #8
5	3400384	2	WASHER, 5/16 BELLEVILLE
6	600134	1	BRACKET, F/R PEDAL
7	600135	1	PEDAL, F/R
8	600175	1	ROD END, FEM 1/4-28
9	600578	1	RUE-RING, .50
10	600851	1	M8-1.25 INSERT, .125 GRIP
11	600934	2	NUT, M8-1.25 FLNG
12	620027	1	PIN, CLEVIS 1/2 X 4.50
13	620033	1	BOLT, M8-1.25 X 65 HH
14	620136	2	BOLT, #8-32 X 1.25 HH ZP
15	711373	1	NUT, FIBER INSERT 1/4-20
16	713003	1	SCREW, 1/4-20 X 1.00 HH
17	717024	2	BOLT, M8-1.25 X 20 HH
18	730356	1	CABLE, JACKETED, 92.50 OAL
19	PART OF 730356	2	LOCK WASHER
20	PART OF 730356	1	NUT, 1/4-28
21	PART OF 730356	2	NUT, 5/8-18 JAM
22	REF	-	CONSOLE
23	REF.	-	FRAME

PUMP LINKAGE GROUP (730111)

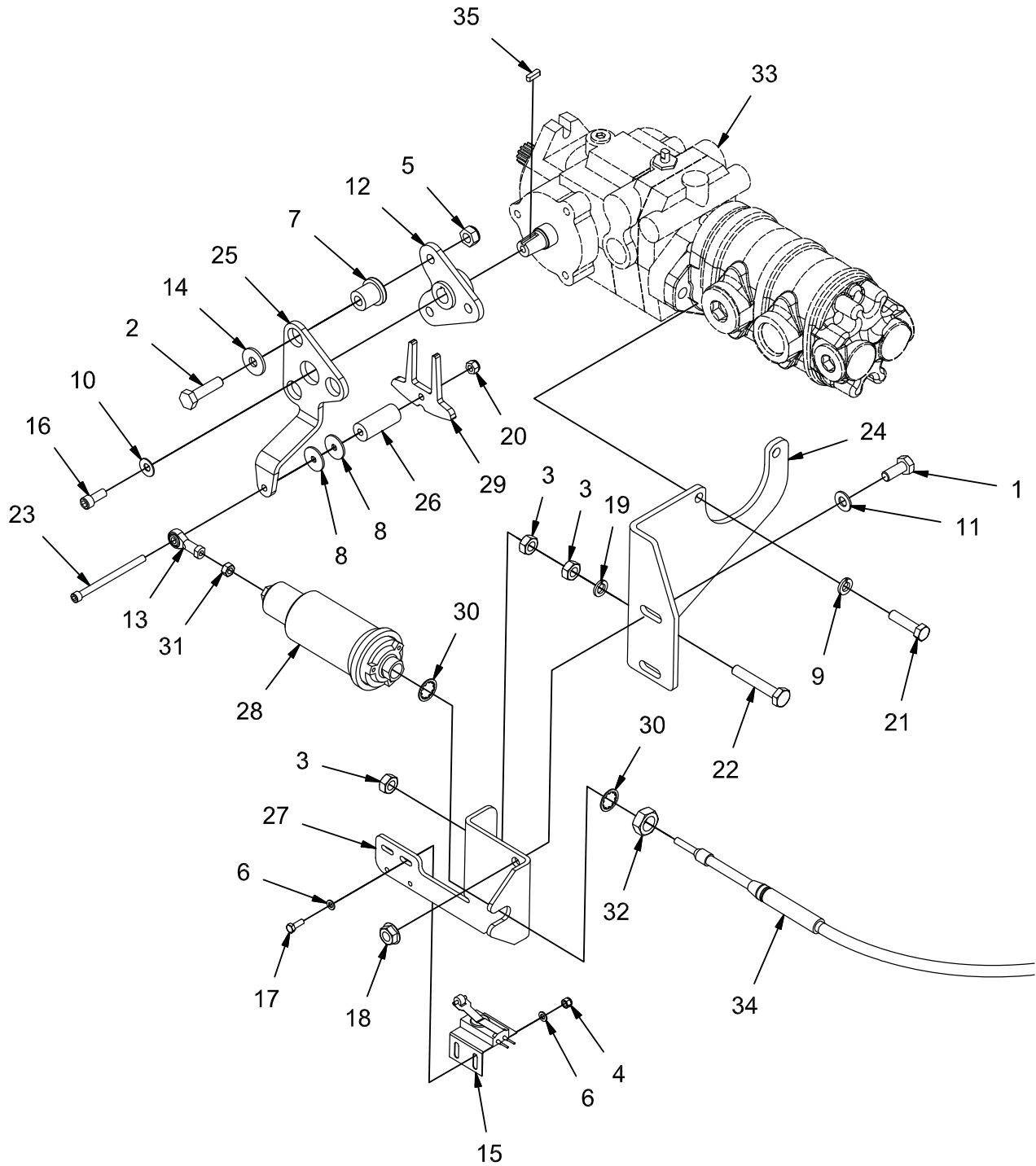

REV D

PUMP LINKAGE GROUP (730111)

Parts List 730111			
ITEM	PART NUMBER	QTY	DESCRIPTION
1	11038346	2	BOLT, M10-1.50 X 25 HH
2	11038395	3	BOLT, M10-1.50 X 40 HH
3	12022067	3	NUT, M10-1.50 HEX
4	12040036	2	NUT, M5 - 0.8 ESN
5	12040069	3	NUT, M10-1.50 ESN
6	12310025	4	WASHER, M5
7	3300465	3	ISOLATOR, VIB
8	3400090	2	WASHER, FENDER, 1/4 ZP
9	3400101	2	LOCK WASHER, 3/8 HS MED
10	3400384	1	WASHER, 5/16 BELLEVILLE
11	3400385	2	WASHER, 3/8, BELLEVILLE
12	600141	1	WELDMENT, DIR CONT HUB
13	600175	1	ROD END, FEM 1/4-28
14	600363	3	WASHER, ISOLATOR
15	600853-1	1	SWITCH, LIMIT, N.O.
16	600895	1	BOLT, 5/16-24 X .75 SHCS
17	600911	2	BOLT, M5-0.8 X 14 HH
18	600936	2	NUT, M10-1.50 FLNG
19	600945	1	LOCK WASHER, M10
20	711373	1	NUT, FIBER INSERT 1/4-20
21	713044	2	SCREW, 3/8-16 X 1.50 HHC
22	730481	1	BOLT, M10-1.50 X 60 HH ALL-THRD
23	730699	1	BOLT, 1/4-20 X 3.50 SOC HD CAP
24	730714	1	MOUNT, HYDROBACK
25	730715	1	ARM, DIR CONT
26	731108	1	SPACER, .266 B .750 OD 1.81 T
27	731109	1	ADJUSTER, HYDROBACK W/SW MNT
28	731181	1	HYDROBACK CENTERING UNIT, 10 LB
29	731238	1	CAM, NEUTRAL
30	PART OF CABLE ASSY	2	LOCK WASHER
31	PART OF CABLE ASSY	1	NUT, 1/4-28
32	PART OF CABLE ASSY	1	NUT, 5/8-18 JAM
33	REF.	-	PUMP, PROPULSION
34	REF.	-	CABLE, PUSH-PULL
35	WITH PUMP	1	KEY

SCRUB HEAD GROUP (730112)

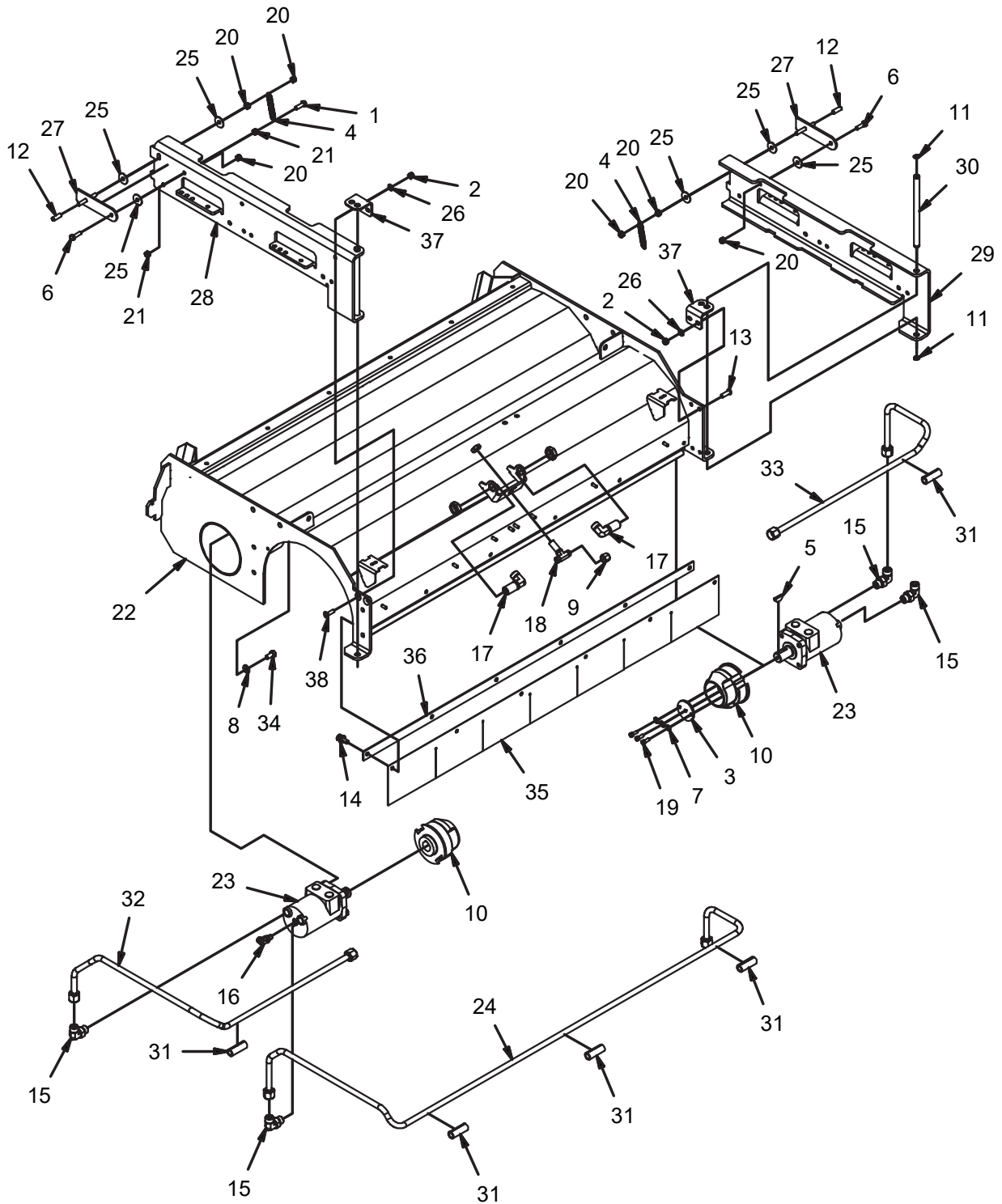

REV G

SCRUB HEAD GROUP (730112)

Parts List 730112			
ITEM	PART NUMBER	QTY	DESCRIPTION
1	11039567	1	BOLT, M8-1.25 X 25 HH SS
2	12040259	4	NUT, M8-1.25 ESN SS
3	3301285	2	RETAINER, MAIN BROOM DRIVE HUB
4	3304160	2	SPRING, EXT
5	3330338	2	KEY, WOODRUFF .25 X .50
6	3400318	2	BOLT, 5/16-18 X 1.00 HH SS
7	3400383	6	WASHER, 1/4 BELLEVILLE
8	3400385	8	WASHER, 3/8, BELLEVILLE
9	675605	1	FITTING, CAP -4 ORFS
10	600337	2	HUB, MAIN BROOM DRIVE
11	600569	4	RETAINING RING, EXT .50 HD
12	600910	2	CAP
13	600917	2	SCREW, M8-1.25 X 25 BUTTON HD CAP SS
14	600965	6	FASTENER, PRESS-IN
15	675523	4	FITTING, 90, -8 ORFS - 8 SAE
16	675541	1	FITTING, 45, 4 ORFS - 4 SAE
17	675544	2	FITTING, 90, BULKHEAD 8 ORFS - 8 ORFS
18	675607	1	FITTING, BULKHEAD TEE - 4 ORFS - 4 ORFS
19	712331	6	BOLT, 1/4-20 X .625 SHCS SS
20	712683	6	NUT, 5/16-18 ESN SS
21	717029	2	NUT, M8-1.25 SS
22	730325MBC	1	WELDMENT, SCRUB HEAD
23	730343	2	MOTOR, 4.5 DISP
24	730348	1	ASSEMBLY, CROSS TUBE
25	730526	6	WASHER, M8 FENDER SS
26	730609	4	WASHER, M8 SS
27	730622	2	WELDMENT, DOOR LATCH
28	730626	1	SQU MNT CHANNEL, RH
29	730627	1	SQU MNT CHANNEL, LH
30	730642	2	SHAFT, .50 D X 8.00 L
31	730685	5	GUARD, HOSE
32	730775	1	ASSEMBLY, RH MOTOR TUBE
33	730776	1	ASSEMBLY, LH MOTOR TUBE
34	730959	8	SCREW, 3/8-16 X .750 HHC SS
35	730982	1	SKIRT, SCRUB HEAD
36	730983	1	STRAP, RETAINER
37	731131	2	HINGE, ADJ
38	731139	2	SCREW, M8-1.25 X 25 FHCS SS

SCRUB BRUSH LIFT GROUP (730113)

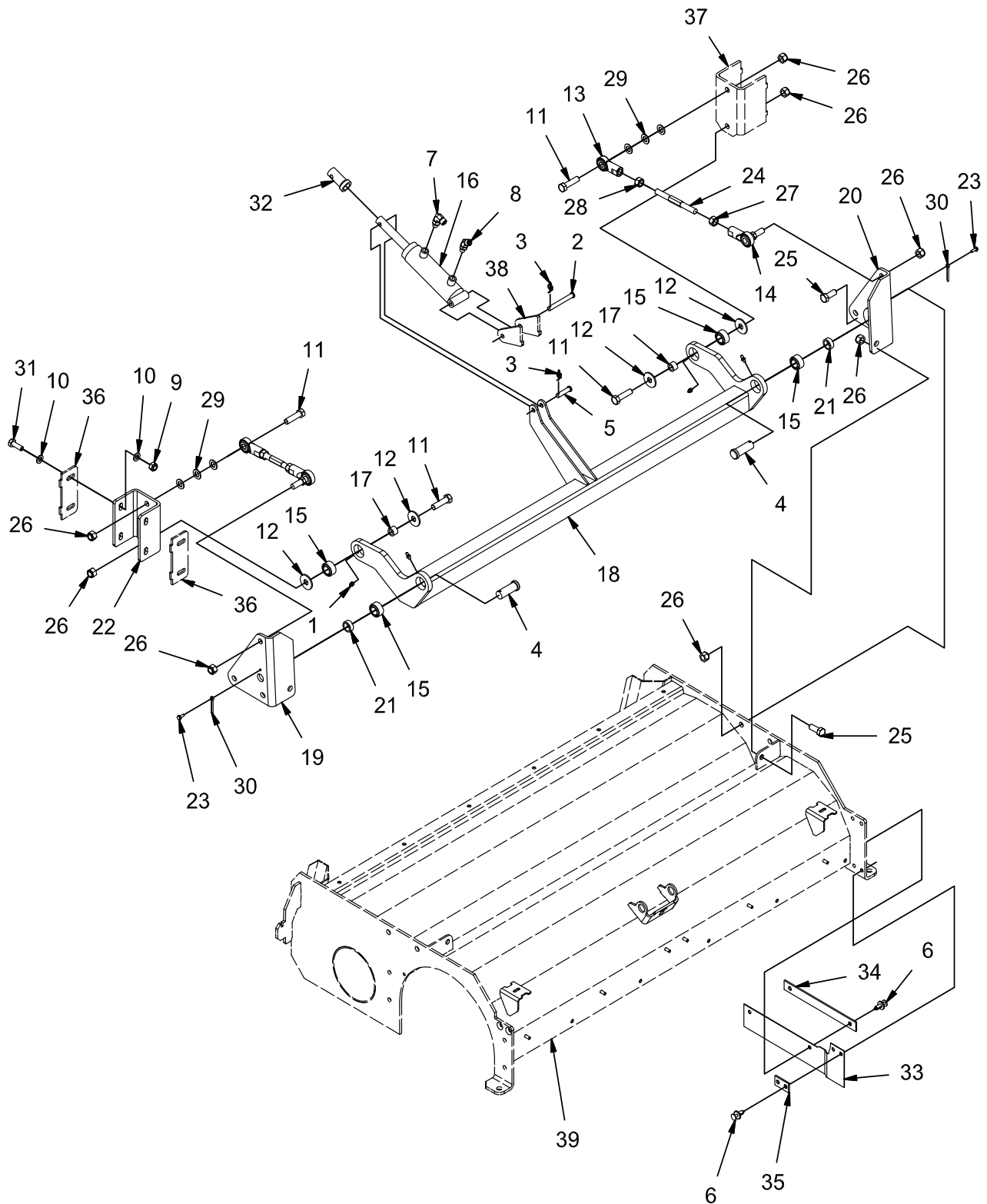

REV B

SCRUB BRUSH LIFT GROUP (730113)

Parts List 730113			
ITEM	PART NUMBER	QTY	DESCRIPTION
1	3400012	4	GREASE ZIRK
2	3400115	1	PIN, CLEVIS, .375 X 3.00
3	3400125	2	RUE-RING, .375
4	3400439	2	CLEVIS PIN, .75 X 2.00
5	600573	1	PIN, CLEVIS, 3/8 X 1.50
6	600965	4	FASTENER, PRESS-IN
7	675507	1	FITTING, 90, -4 ORFS - 4 SAE
8	675541	1	FITTING, 45, 4 ORFS - 4 SAE
9	730339	4	NUT, M10-1.50 ESN SS
10	730344	8	WASHER, M10 SS
11	730516	4	BOLT, M12-1.75 X 45 HH SS
12	730528	4	WASHER, .512 B 1.46 OD .118 T SS
13	730544	2	ROD END, FEM, M12-1.75
14	730545	2	ROD END, FEM, M12-1.75 LH THRD W/STUD
15	730547	4	BEARING, SPHERICAL
16	730548	1	CYLINDER, HYD, 1.5 B X 2.88 STK
17	730549	2	SPACER, .484 B .746 OD .500 T
18	730590	1	WELDMENT, SH LIFT ARM
19	730594	1	WELDMENT, SH LIFT BRACKET RH
20	730597	1	WELDMENT, SH LIFT BRACKET, LH
21	730599	2	SPACER, .760 B 1.00 OD .375 T
22	730600	1	CHANNEL, SH ADJ MNT
23	730601	2	SCREW, #10-32 x .50 SELF TAPPING SS
24	730603	2	ROD, ADJ
25	730604	6	BOLT, M12-1.75 X 30 HH SS
26	730605	12	NUT, M12-1.75 ESN SS
27	730606	2	NUT, M12-1.75 LH THRD SS
28	730607	2	NUT, M12-1.75 HEX SS
29	730608	6	WASHER, M12 SS
30	730610	2	PIN, COTTER, .156 X 1.25 SS
31	730878	4	BOLT, M10-1.50 X 30 HH SS
32	731194	1	TUBE, STOP
33	731362	1	SKIRT, SIDE
34	731363	1	SKIRT RETAINER, REAR
35	731364	1	SKIRT RETAINER, FRONT
36	REF.	-	FRAME
37	REF.	-	FRAME
38	REF.	-	FRAME
39	REF.	-	SCRUB HEAD

SCRUB BRUSH IDLER GROUP (730114)

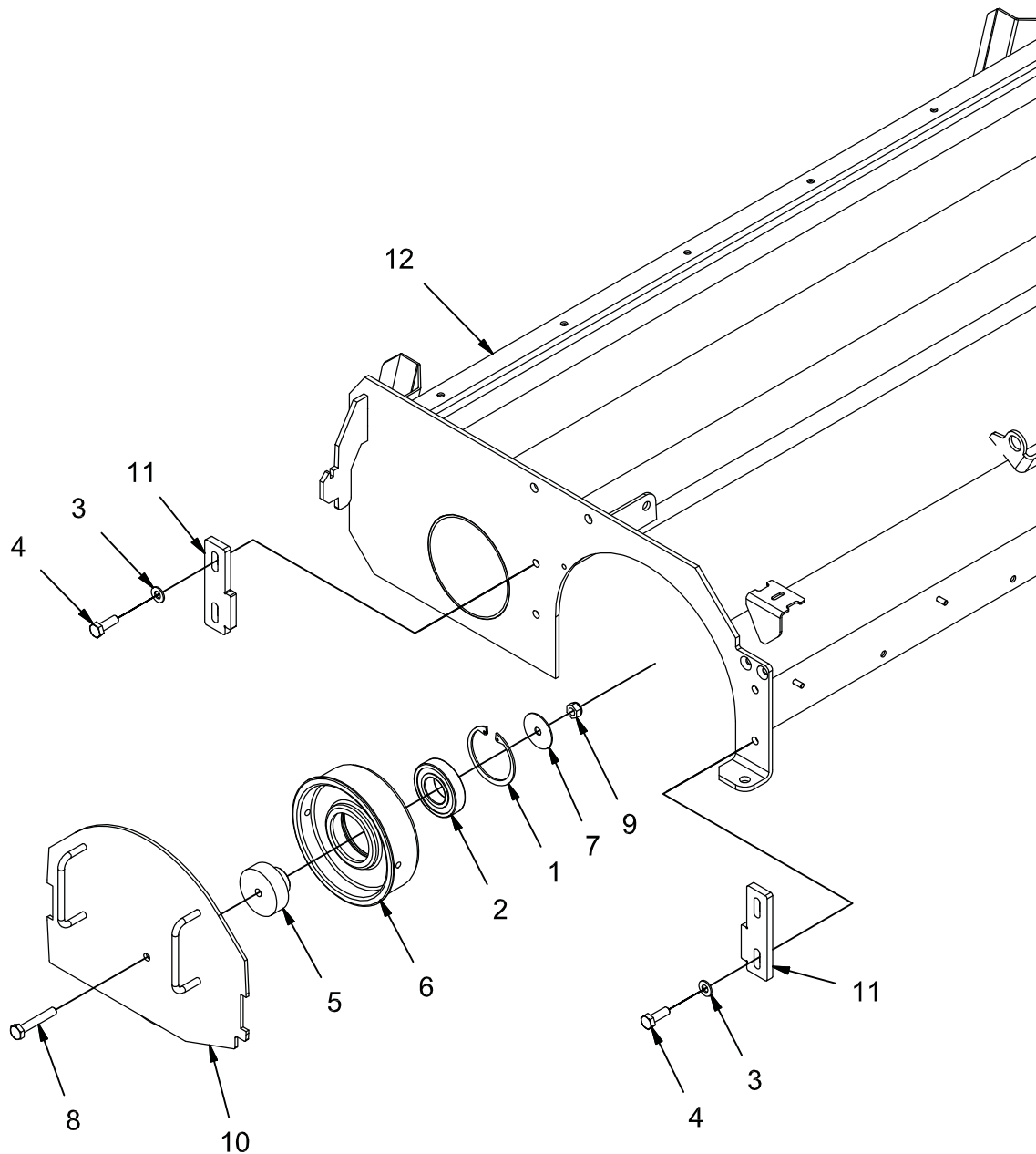

REV C

SCRUB BRUSH IDLER GROUP (730114)

Parts List 730114			
ITEM	PART NUMBER	QTY	DESCRIPTION
1	3305666	2	RING, RETAINING, INT
2	3305667	2	BEARING, BALL, 207PP
3	3400385	8	WASHER, 3/8, BELLEVILLE
4	730878	8	BOLT, M10-1.50 X 30 HH SS
5	600544	2	MOUNT, BEARING
6	620083	2	IDLER, MAIN BROOM
7	712768	2	WSR-FLT .406 X 1.875 SS
8	730323	2	BOLT, M10-1.50 X 60 HH SS
9	730339	2	NUT, M10-1.50 ESN SS
10	730341	2	WELDMENT, BRUSH RETAINER
11	730613	4	PLT, ADJ
12	REF.	-	SCRUB HEAD

BRUSH DOOR GROUP (730115)

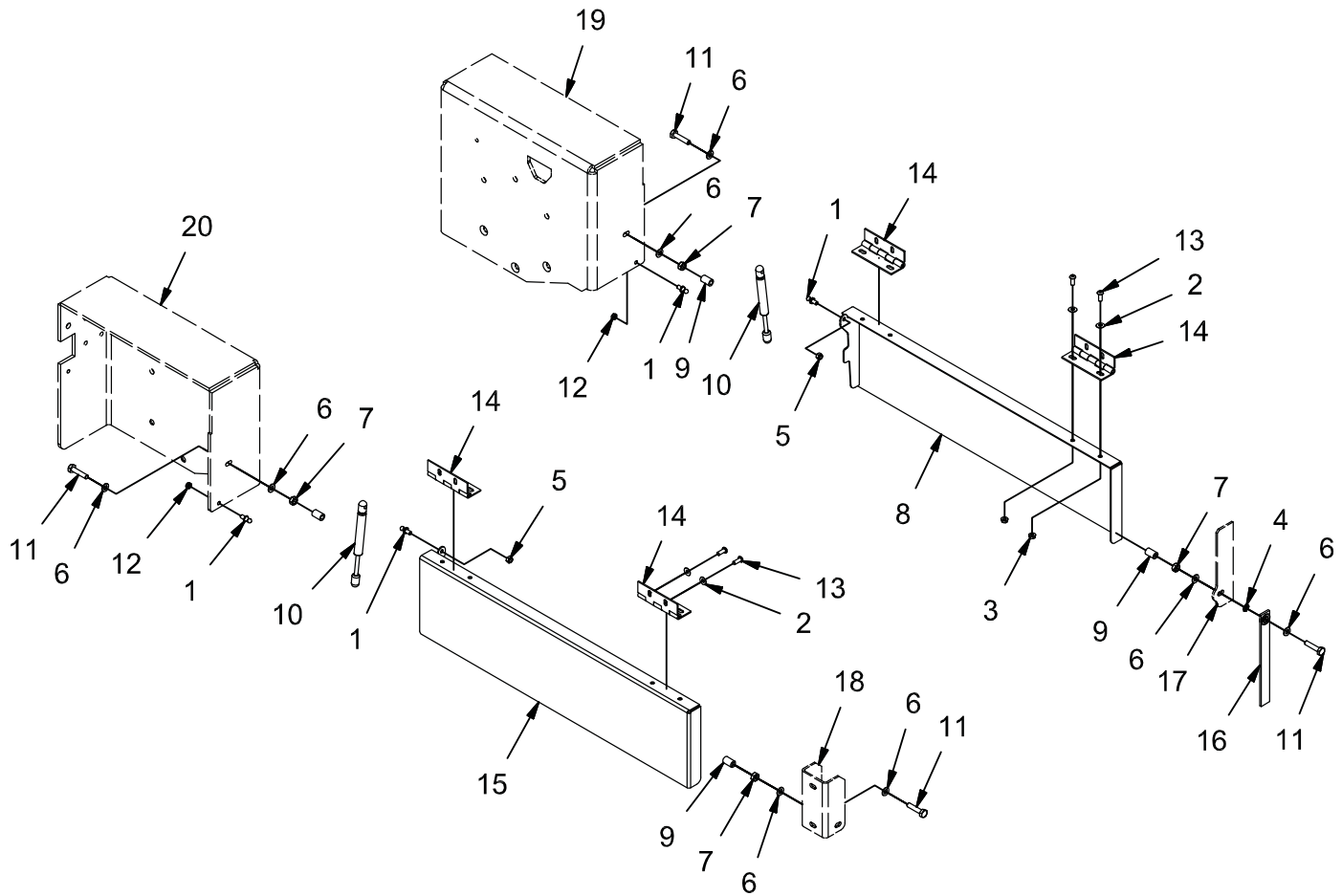

REV A

BRUSH DOOR GROUP (730115)

Parts List 730115			
ITEM	PART NUMBER	QTY	DESCRIPTION
1	3300376	4	STUD, 10MM BALL
2	3400384	16	WASHER, 5/16 BELLEVILLE
3	600934	8	NUT, M8-1.25 FLNG
4	600946	1	LOCK WASHER, 3/8 INT STAR
5	712683	2	NUT, 5/16-18 ESN SS
6	730344	8	WASHER, M10 SS
7	730718	4	NUT, M10-1.50 HEX SS
8	730900	1	WELDMENT, LH BRUSH DOOR
9	730901	4	TUBING, STOP
10	730902	2	GAS STRUT, 8.77 EXT, 3.00 STK, 200N
11	730903	4	BOLT, M10-1.50 X 45 HH SS
12	730904	2	NUT, 5/16-18 HEX JAM SS
13	730905	16	SCREW, M8-1.25 X 20 BUTTON HD CAP SS
14	730906	4	HINGE, 5"
15	730951	1	WELDMENT, RH BRUSH DOOR
16	730979-1	1	STRAP, STATIC
17	REF.	-	FRAME
18	REF.	-	FRAME
19	REF.	-	FRAME
20	REF.	-	FRAME

SQUEEGEE LIFT GROUP (730119)

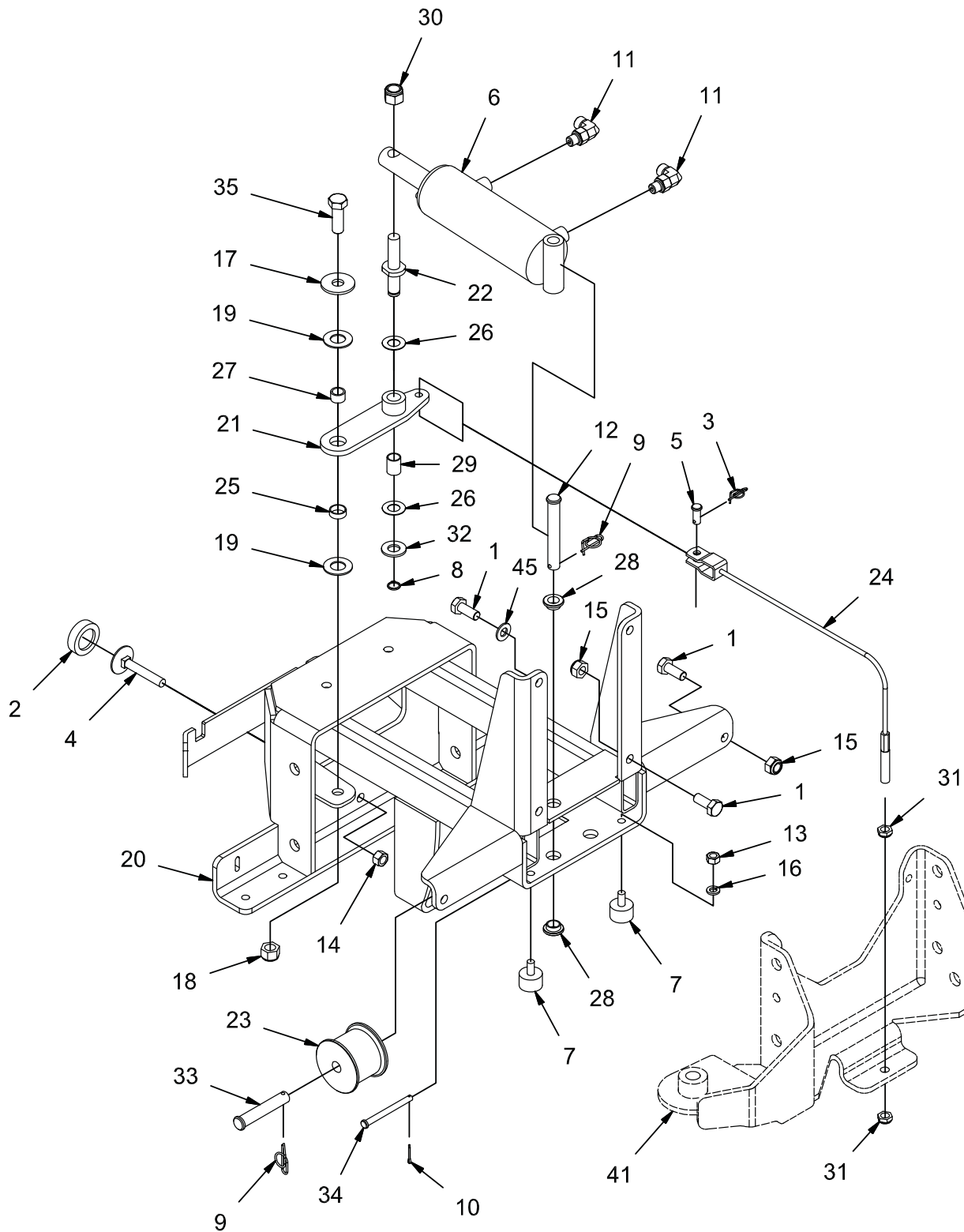

REV D

SQUEEGEE LIFT GROUP (730119)

Parts List 730119			
ITEM	PART NUMBER	QTY	DESCRIPTION
1	11039328	6	BOLT, M10-1.50 X 25 HH SS
2	3304624	1	CAP, RUBBER BUMPER
3	3400125	1	RUE-RING, .375
4	3400355	1	SCR, LEVEL BOLT, 3/8-16 X 2.50
5	450034	1	PIN, CLEVIS, .313 X .75
6	600106	1	CYLINDER
7	600220	2	BUMPER, 1.00 X .625 T
8	600569	1	RETAINING RING, EXT .50 HD
9	600578	2	RUE-RING, .50
10	620143	1	COTTERPIN, 5/64 X 1/2
11	675507	2	FITTING, 90, 4 ORFS - 4 SAE
12	712098	1	PIN, CLEVIS 1/2 X 3.50
13	712680	2	NUT, HEX 5/16-18 SS
14	712695	1	NUT, HEX 3/8-16 SS
15	730339	4	NUT, M10-1.50 ESN SS
16	730527	2	LOCK WASHER, M8, SS
17	730528	1	WASHER, .512 B 1.46 OD .118 T SS
18	730605	1	NUT, M12-1.75 ESN SS
19	730647	2	WASHER, THRUST, .66 B 1.25 OD .06 T
20	730724	1	WELDMENT, SQU LIFT
21	730738	1	WELDMENT, SQU LIFT ARM
22	730741	1	PIN, SQU LIFT
23	730745	1	PULLEY
24	730746	1	CABLE ASSEMBLY
25	730747	1	BEARING, DU .625 ID .25 L
26	3400178	2	WASHER, THRUST, .53 B 1.00 OD .03 T
27	730749	1	SPACER, .484 B .622 ID .390 T
28	730750	2	BUSHING, BRONZE, FLANGED. .50 B .62 OD .31 T
29	730752	1	FIBERGLIDE BEARING, .500 ID .750 T
30	730756	1	NUT, 1/2-13 ESN, SS
31	730757	2	NUT, 3/8-24 JAM ESN SS
32	730759	1	WASHER, 1/2, SS
33	730760	1	PIN, CLEVIS 1/2 X 2.75
34	730761	1	PIN, CLEVIS, .25 X .2.75
35	730762	1	BOLT, M12-1.75 X 35 HH SS
45	3400385	2	WASHER, 3/8, BELLEVILLE

SQUEEGEE LINKAGE GROUP (730158)

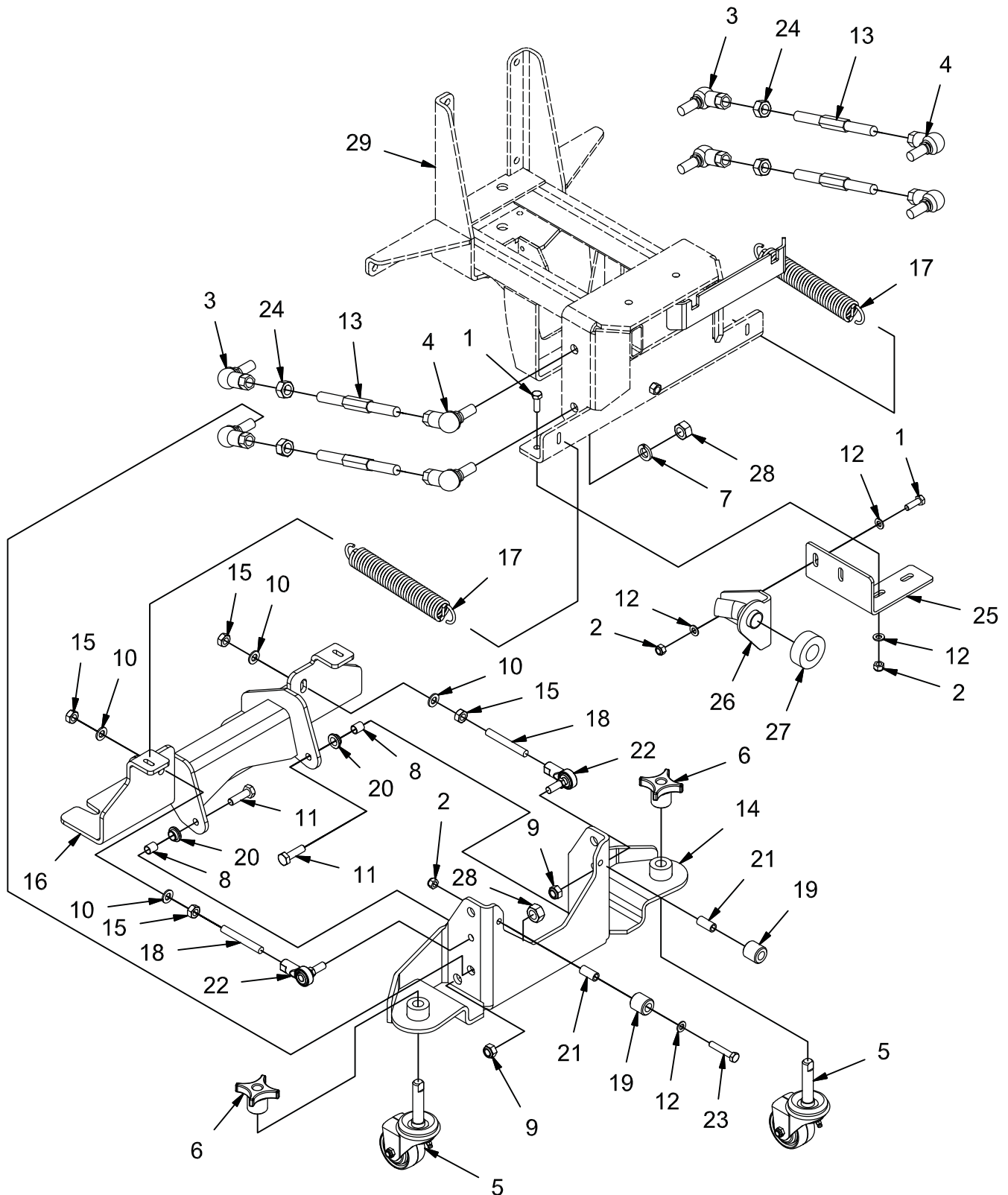

REV C

SQUEEGEE LINKAGE GROUP (730158)

Parts List 730158			
ITEM	PART NUMBER	QTY	DESCRIPTION
1	11039567	4	BOLT, M8-1.25 X 25 HH SS
2	12040259	6	NUT, M8-1.25 ESN SS
3	16046054	4	ROD END, M14 RH THRDS
4	16046062	4	ROD END, M14 LH THRDS
5	3343816	2	CASTER
6	3343819	2	KNOB
7	3400414	8	LOCK WASHER, 9/16 HS MED
8	600525	2	SPACER, .406 B .50 OD .57 T
9	730339	4	NUT, M10-1.50 ESN SS
10	730344	4	WASHER, M10 SS
11	730345	2	BOLT, M10-1.50 X 35 HH SS
12	730609	8	WASHER, M8 SS
13	730662	4	ROD, SQUEEGEE
14	730674	1	WELDMENT, SQU BRACKET
15	730718	4	NUT, M10-1.50 HEX SS
16	730720	1	WELDMENT, SQU MNT
17	730742	2	SPRING, EXT, .160 W 1.25 OD 10.25 L SS
18	730743	2	ROD, TREADED, M10-1.50
19	730744	2	ROLLER, SQU
20	730750	2	BUSHING, BRONZE, FLANGED. .50 B .62 OD .31 T
21	730751	2	SPACER, .344 B .500 OD 1.06 T
22	730753	2	ROD END, M10-1.50
23	730754	2	BOLT, M8-1.25 X 45 HH SS
24	731176	4	NUT, M14-1.50 HEX SS
25	730839	1	BRACKET, ADJ
26	730847	1	WELDMENT, HOSE ADJ
27	730848	1	SEAL
28	PART OF ROD END	8	NUT, M14-1.50 HEX
29	REF	-	SQUEEGEE LIFT WELDMENT

SQUEEGEE GROUP (730118)

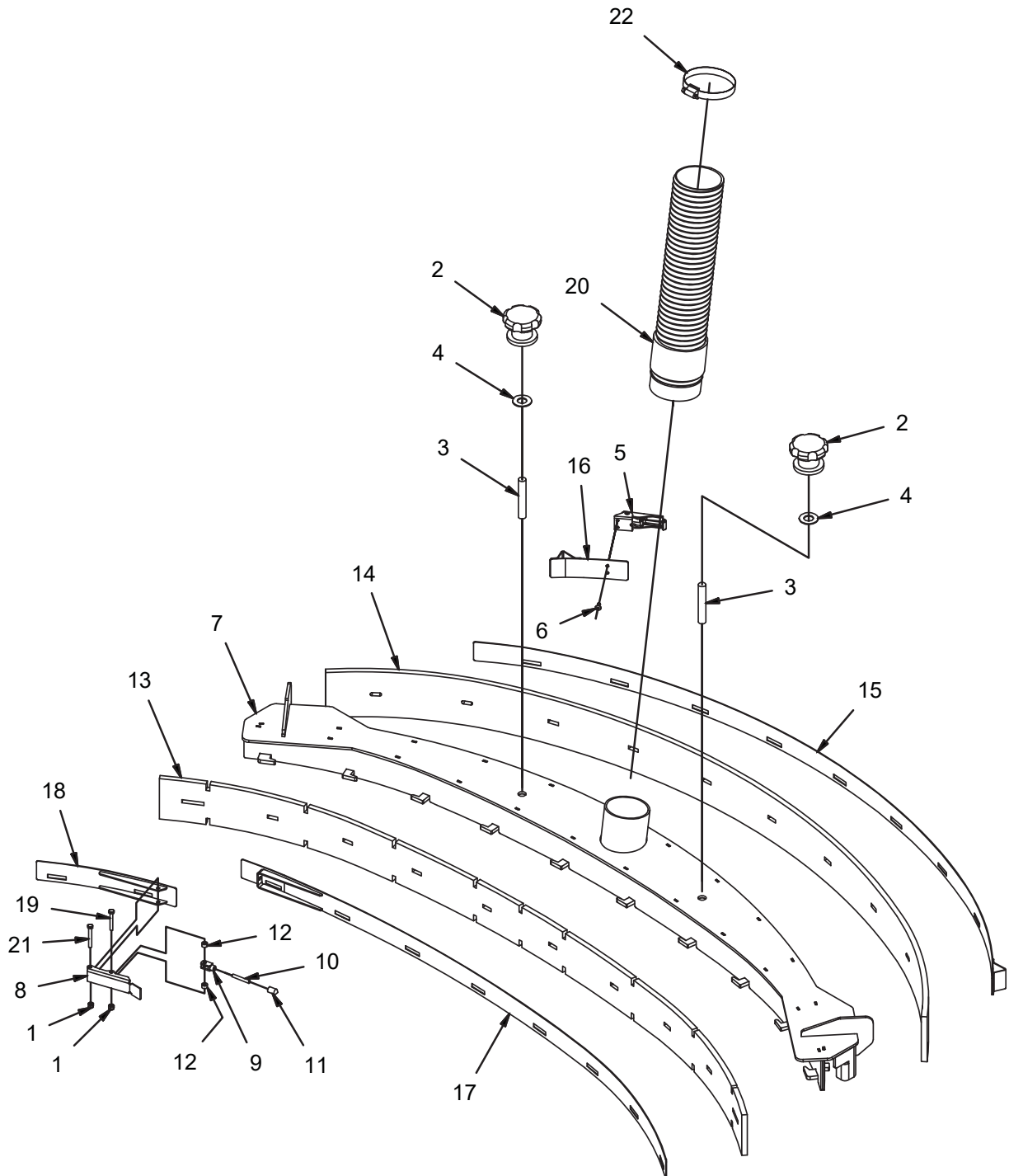

REV E

SQUEEGEE GROUP (730118)

Parts List 730118			
ITEM	PART NUMBER	QTY	DESCRIPTION
1	12040283	2	NUT, M5 - 0.8 ESN SS
2	3343814	2	KNOB
3	3343903	2	STUD, 1/2-13 X 3.00 SS
4	3401543	2	WASHER, TOOTHED PERIPHERY
5	730652	1	LATCH, UNDER CENTER
6	730654	2	RIVET,BLIND, .156 D X .062 - .125 GRIP SS
7	730764	1	WELDMENT, SQUEEGEE
8	730780	1	LATCH, BODY
9	730781	1	CLEVIS, M5-0.8
10	730782	1	ROD, M5-0.8
11	730783	1	ROD, NOSE
12	730784	2	SPACER, .203 B .375 OD .210 T
13	730787	1	SQUEEGEE BLADE, FRONT
14	730788	1	SQUEEGEE BLADE, REAR
15	730791	1	WELDMENT, REAR RETAINER
16	730796	1	WELDMENT, REAR RETAINER, SHORT
17	730798	1	WELDMENT, FRONT RETAINER
18	730800	1	WELDMENT, FRONT RETAINER, SHORT
19	730802	1	BOLT, M5-0.8 X 35 HH SS
20	730985	1	ASSEMBLY, LOWER SQU HOSE
21	731130	1	BOLT, M5-0.8 X 40 HH SS
22	731144	1	CLAMP, HOSE, 2.25 - 3.25

SIDE SQUEEGEE GROUP - RH (730120)

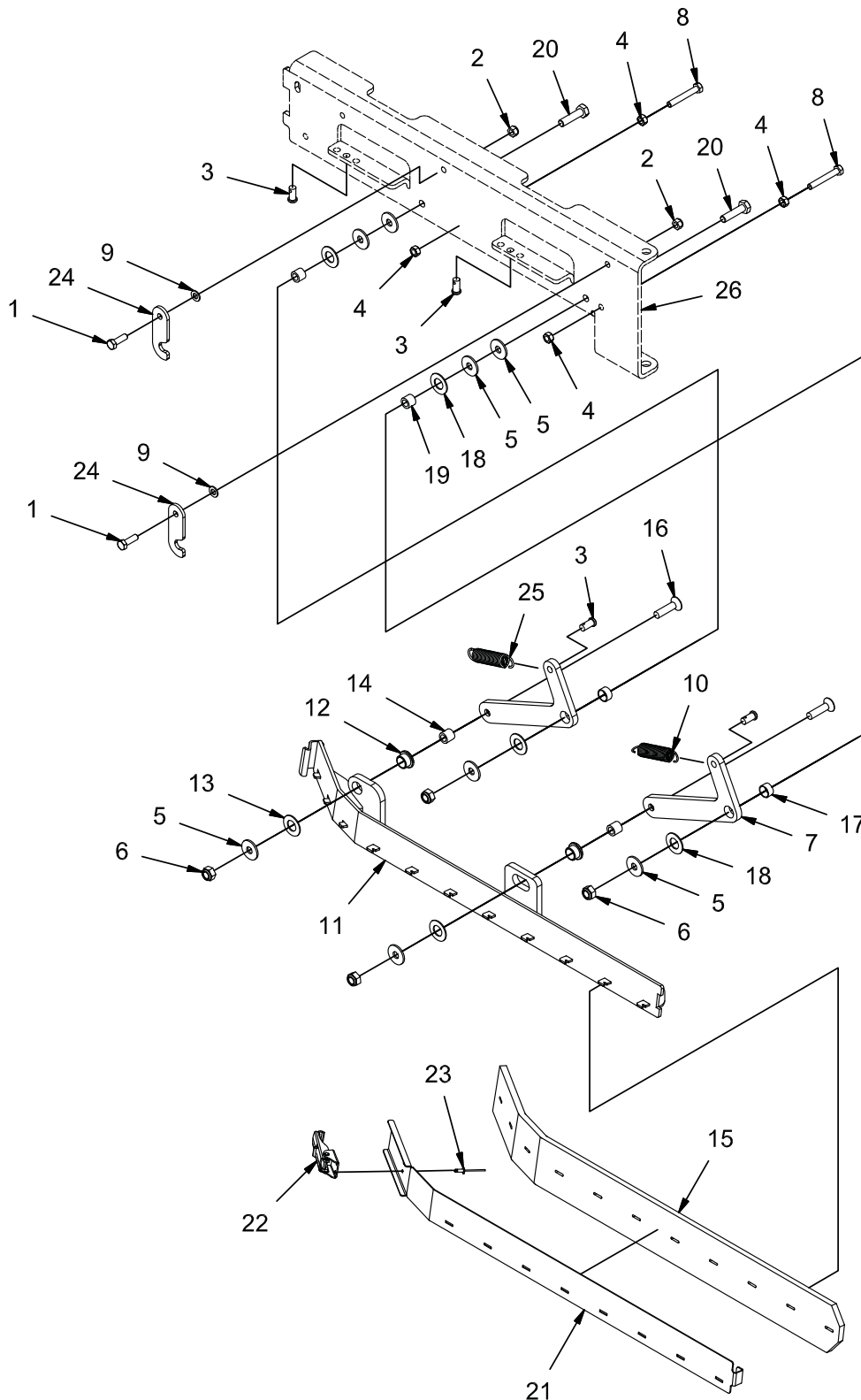

REV B

SIDE SQUEEGEE GROUP - RH (730120)

Parts List 730120			
ITEM	PART NUMBER	QTY	DESCRIPTION
1	11039567	2	BOLT, M8-1.25 X 25 HH SS
2	12040259	2	NUT, M8-1.25 ESN SS
3	711679	4	PIN, CLEVIS, .375 X .75
4	717029	4	NUT, M8-1.25 SS
5	717040	8	WASHER, FENDER, .413 B 1.18 OD .098 T SS
6	730339	4	NUT, M10-1.50 ESN SS
7	730346	2	ARM, SIDE SQU, RH
8	730507	2	BOLT, M8-1.25 X 55 HH SS
9	730609	2	WASHER, M8 SS
10	730619	1	SPRING, EXT, .07 W .75 OD 3.50 L SS
11	730630	1	WELDMENT, SQU MNT, RH
12	730640	2	BUSHING, BRONZE FLANGED, .62 B .75 OD .50T
13	730641	2	WASHER, BACKED THRUST .66 B 1.25 OD .06 T
14	730643	2	SPACER, .406 B .623 OD .570 T SS
15	730644	1	SQUEEGEE, SIDE
16	730645	2	SCREW, M10-1.50 X 40 FLAT HD SOC HD SS
17	730646	2	BEARING, DU, .63 B .72 OD .38 T
18	730647	4	WASHER, THRUST, .66 B 1.25 OD .06 T
19	730648	2	SPACER, .406 B .624 OD .515 T SS
20	730649	2	BOLT, M10-1.50 X 40 HH SS
21	730650	1	STRAP, RH SQU
22	730652	1	LATCH, UNDER CENTER
23	730654	2	RIVET,BLIND, .156 D X .062 - .125 GRIP SS
24	730990	2	LATCH, DOUBLE SCRUB
25	731183	1	SPRING, EXT, .09 W .75 OD 3.50 L SS
26	REF	-	SQU MNT CHANNEL, RH

SIDE SQUEEGEE GROUP - LH (730157)

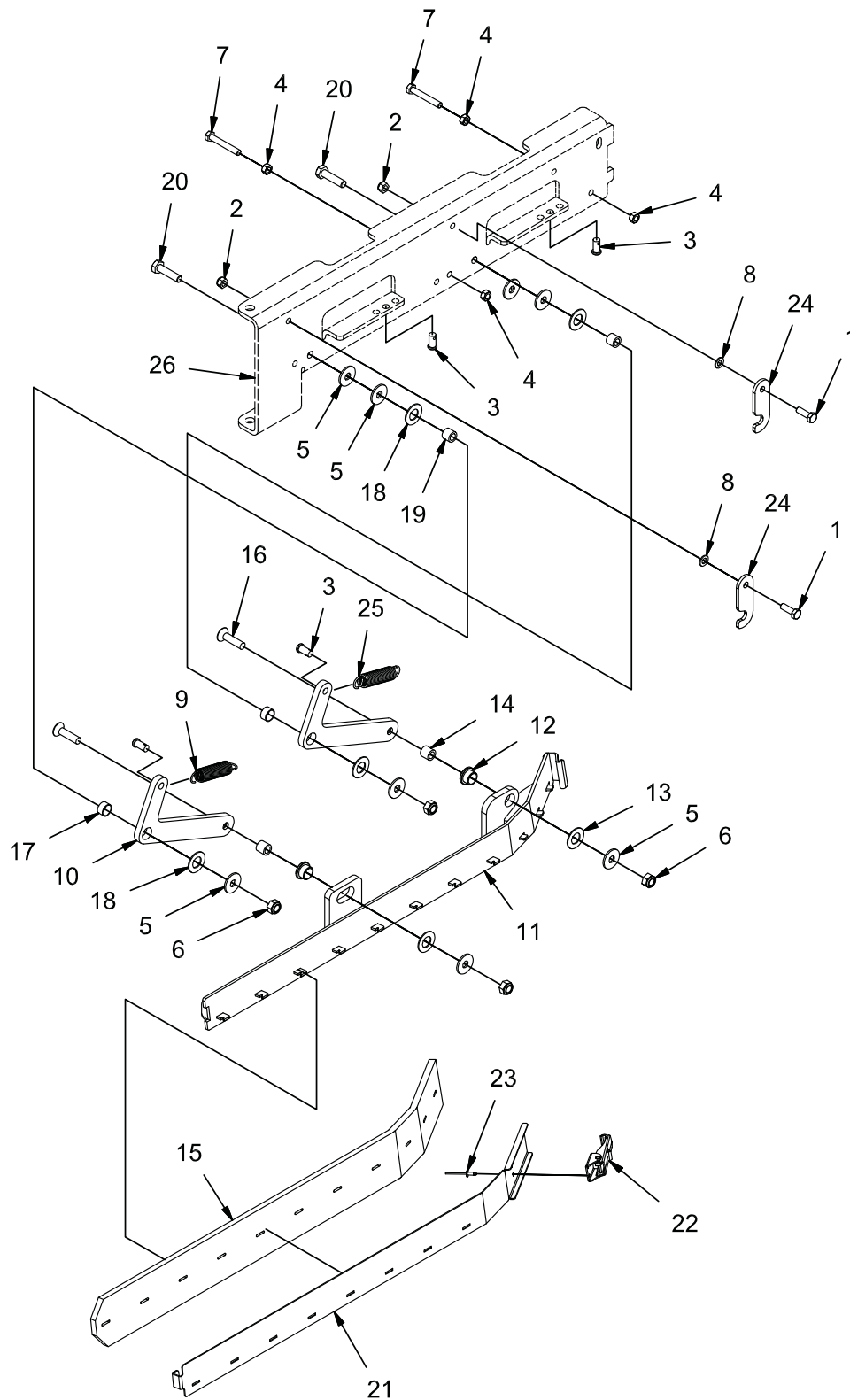

REV B

SIDE SQUEEGEE GROUP - LH (730157)

Parts List 730157			
ITEM	PART NUMBER	QTY	DESCRIPTION
1	11039567	2	BOLT, M8-1.25 X 25 HH SS
2	12040259	2	NUT, M8-1.25 ESN SS
3	711679	4	PIN, CLEVIS, .375 X .75
4	717029	4	NUT, M8-1.25 SS
5	717040	8	WASHER, FENDER, .413 B 1.18 OD .098 T SS
6	730339	4	NUT, M10-1.50 ESN SS
7	730507	2	BOLT, M8-1.25 X 55 HH SS
8	730609	2	WASHER, M8 SS
9	730619	1	SPRING, EXT, .07 W .75 OD 3.50 L SS
10	730620	2	ARM, SIDE SQU, LH
11	730637	1	WELDMENT, SQU MNT, LH
12	730640	2	BUSHING, BRONZE FLANGED, .62 B .75 OD .50T
13	730641	2	WASHER, BACKED THRUST .66 B 1.25 OD .06 T
14	730643	2	SPACER, .406 B .623 OD .570 T SS
15	730644	1	SQUEEGEE, SIDE
16	730645	2	SCREW, M10-1.50 X 40 FLAT HD SOC HD SS
17	730646	2	BEARING, DU, .63 B .72 OD .38 T
18	730647	4	WASHER, THRUST, .66 B 1.25 OD .06 T
19	730648	2	SPACER, .406 B .624 OD .515 T SS
20	730649	2	BOLT, M10-1.50 X 40 HH SS
21	730651	1	STRAP, LH SQU
22	730652	1	LATCH, UNDER CENTER
23	730654	2	RIVET,BLIND, .156 D X .062 - .125 GRIP SS
24	730990	2	LATCH, DOUBLE SCRUB
25	731183	1	SPRING, EXT, .09 W .75 OD 3.50 L SS
26	REF	-	SQU MNT CHANNEL, LH

SOLUTION TANK GROUP (730121)

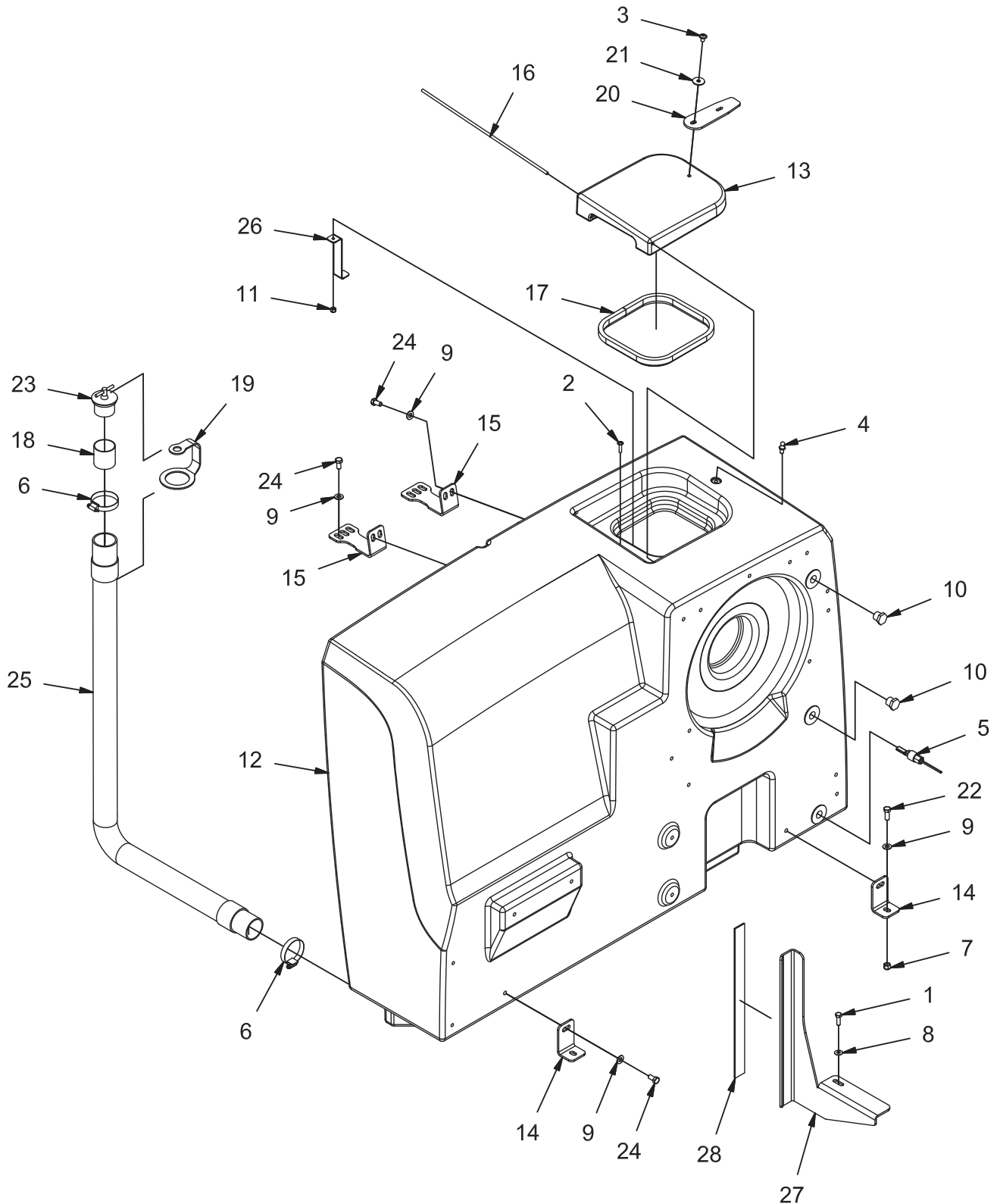

REV F

SOLUTION TANK GROUP (730121)

Parts List 730121			
ITEM	PART NUMBER	QTY	DESCRIPTION
1	11038247	1	BLT-HH M8-1.25 X 25 STL ZINC
2	11177161	1	SCREW, M6-1.00 X 25 BUTTON HD CAP W/FLANGE SS
3	11177253	1	SC BHCS W/ FLANGE M8-1.25 X 12 SS
4	3300376	1	STUD, 10MM BALL
5	3302737-1	1	WIRE ASSY, SWITCH - LEVEL LS7
6	3312189	2	CLAMP, HOSE, 2.00
7	3400340	2	NUT, 3/8-16 ESN SS
8	3400384	1	WASHER, 5/16 BELLEVILLE
9	3400385	8	WASHER, 3/8, BELLEVILLE
10	500122	2	1/2 NPT PLASTIC PLUG
11	600933	1	NUT, M6-1.00 ESN SS
12	730458	1	TANK, SOLUTION
13	730480	1	COVER, ACCESS, SOL TANK
14	730491	2	BRACKET, TANK MNT
15	730492	2	BRACKET, TANK MNT
16	730493	1	ROD, SOL COVER
17	730494	1	SEAL, SOL COVER
18	730518	1	TUBE, SS
19	730520	1	LANYARD, CAP
20	730525	1	RETAINER, COVER
21	730526	1	WASHER, M8 FENDER SS
22	730529	2	SCREW, 3/8-16 X 1.00 HH SS
23	730531	1	PLUG, EXPANSION, 1.88
24	730959	6	SCREW, 3/8-16 X .750 HHC SS
25	730987	1	ASSEMBLY, SOL DRAIN HOSE
26	731184	1	INDICATOR, FULL TANK
27	731273-1	1	BRACKET, SUPPORT
28	PART OF 731273-1	1	FRICITION STRIP 281470-1

SOLUTION CONTROL GROUP (730123)

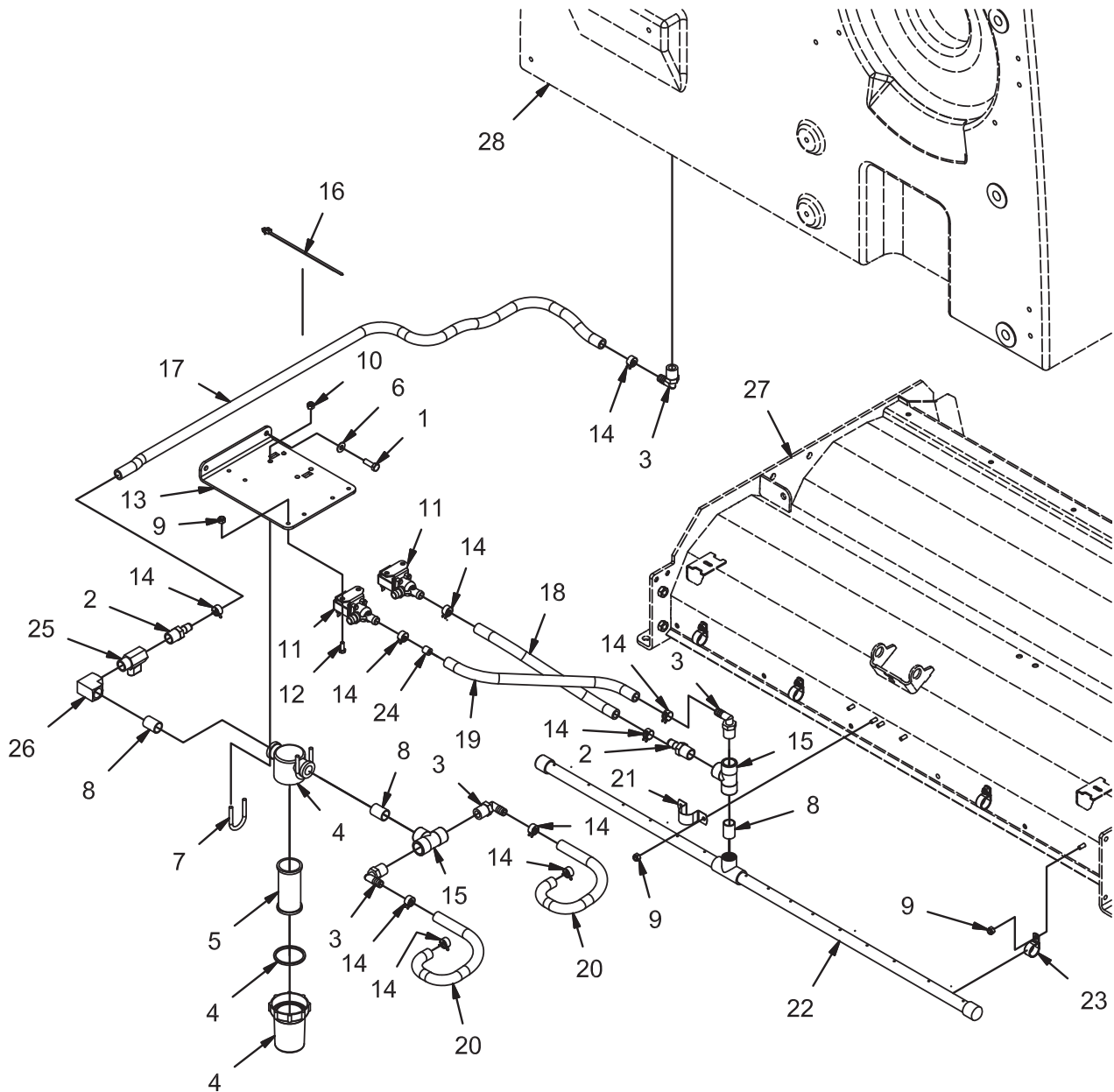

REV G

SOLUTION CONTROL GROUP (730123)

Parts List 730123			
ITEM	PART NUMBER	QTY	DESCRIPTION
1	11038247	2	BLT-HH M8-1.25 X 25 STL ZINC
2	3315534	2	FITTING, PLASTIC, STR, .50 NPT .50 BARB
3	3315535	4	FITTING, PLASTIC, 90, .50 NPT .50 BARB
4	3323501	1	FILTER ASSEMBLY
5	3332264	1	FILTER ELEMENT - SERVICE
6	3400384	2	WASHER, 5/16 BELLEVILLE
7	3401981	2	CLAMP
8	383465	3	1/2 NPT CLOSE PIPE NIPPLE, BRASS
9	600933	10	NUT, M6-1.00 ESN SS
10	712667	4	NUT, FIBER INSERT 1/4-20 SS
11	730899	2	VALVE, SOLENOID, 12-V W/.406 DIA. ORIFICE
12	730934	4	BOLT, M6-1.00 X 16 HH SS
13	730955	1	BRACKET, FILTER MNT
14	730962	10	CLAMP, WIRE HOSE
15	730966	2	FITTING, PVC TEE, FEMALE 1/2 NPT
16	730968	4	TIE, MOUNTED CABLE
17	730970	1	TUBING, .50 ID X 48.00 VINYL
18	730971	1	TUBING, .50 ID X 18.50 VINYL
19	730972	1	TUBING, .50 ID X 20.75 VINYL
20	730973	2	TUBING, .50 ID X 14.00 VINYL
21	730974	1	CLAMP, CONDUIT, 1"
22	731389	1	SOLUTION DELIVERY BAR
23	731218	4	CLAMP, .88 HOSE
24	731244	1	ORIFICE, SOLUTION
25	731378	1	BALL VALVE, 1/2" NPT, BRASS
26	731380	1	FITTING, ELBOW, 1/2" FNPT, BRASS
27	REF.	-	SCRUB HEAD
28	REF.	-	SOLUTION TANK

RECOVERY TANK GROUP (730122)

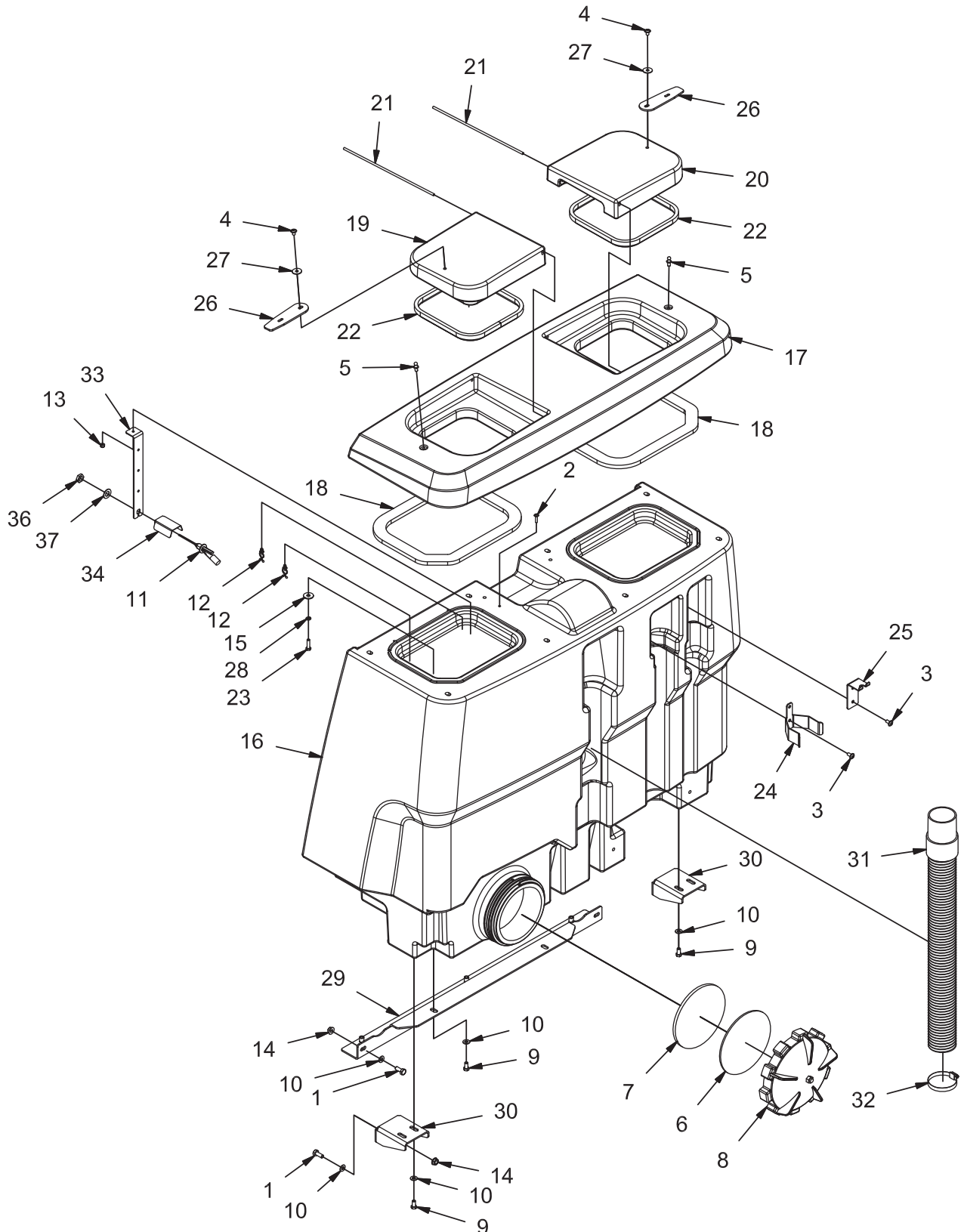

REV G

RECOVERY TANK GROUP (730122)

Parts List 730122			
ITEM	PART NUMBER	QTY	DESCRIPTION
1	11039328	6	BOLT, M10-1.50 X 25 HH SS
2	11177161	1	SCREW, M6-1.00 X 25 BUTTON HD CAP W/FLANGE SS
3	11177187	4	SC-BHCS W/ FLANGE M8 X 1.25 X 16 SS
4	11177253	2	SC BHCS W/ FLANGE M8-1.25 X 12 SS
5	3300376	2	STUD, 10MM BALL
6	3309098	1	PLATE, BACKING FOR 9" CAP GASKET
7	3315258	1	SEAL, CAP
8	3336811	1	ASSEMBLY, CLEAN OUT CAP
9	3400335	4	SCREW, 3/8-16 X .750 HH SS
10	3400385	10	WASHER, 3/8, BELLEVILLE
11	500133-1	1	WIRE ASSY, SWITCH - FLOAT
12	600581	2	CLAMP, WIRE CLIP
13	600933	1	NUT, M6-1.00 ESN SS
14	600936	6	NUT, M10-1.50 FLNG
15	717040	8	WASHER, FENDER, .413 B 1.18 OD .098 T SS
16	730490	1	TANK, RECOVERY
17	730495	1	DEMISTER
18	730496	2	SEAL, DEMISTER
19	730497	1	COVER, LH REC TANK
20	730503	1	COVER, RH REC TANK
21	730504	2	ROD, REC COVER
22	730505	2	SEAL, REC COVER
23	730506	8	BOLT, M8-125 X 30 HH SS
24	730515	1	RETAINER, HOSE
25	730519	1	RETAINER, SOL HOSE
26	730525	2	RETAINER, COVER
27	730526	2	WASHER, M8 FENDER SS
28	730527	8	LOCK WASHER, M8 SS
29	730803-1	1	ASSEMBLY, SUPPORT BEAM
30	730805	2	WELDMENT, TANK BRACKET
31	730984	1	ASSEMBLY, UPPER SQUEEGEE HOSE
32	731144	1	CLAMP, HOSE, 2.25 - 3.25
33	731185	1	REC TANK FLOAT SW MNT
34	731415	1	GUARD, FLOAT
35	748433	1	WIRE ASSY, SWITCH - FLOAT
36	PART OF 500133	1	NUT
37	PART OF 500133	1	GASKET

RECOVERY TANK DRAIN GROUP (730155)

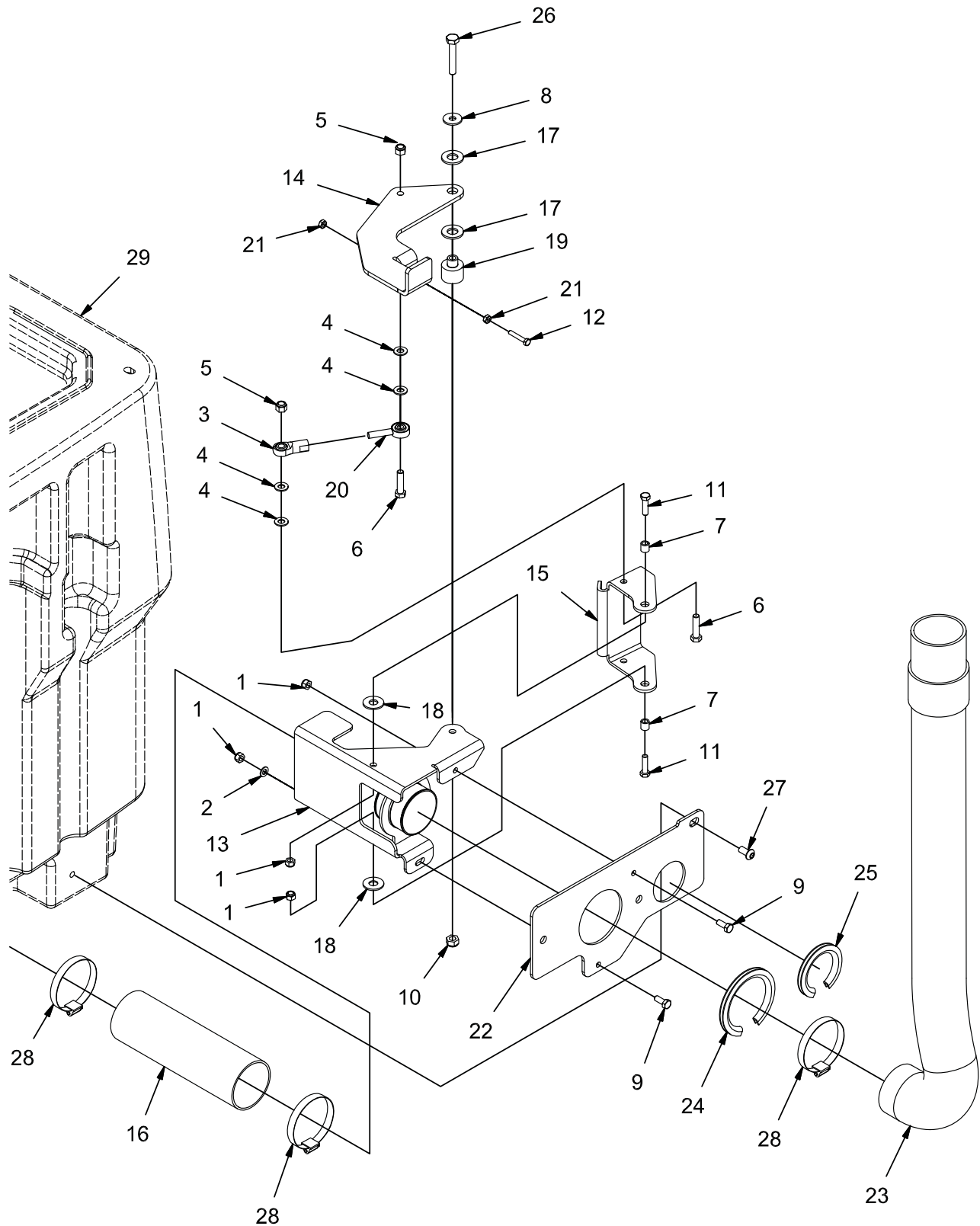

REV C

RECOVERY TANK DRAIN GROUP (730155)

Parts List 730155			
ITEM	PART NUMBER	QTY	DESCRIPTION
1	12040259	4	NUT, M8-1.25 ESN SS
2	12310041	1	WASHER, M8
3	3308762	1	ROD END, 3/8 FEM
4	3400087	4	WASHER, 3/8
5	3400340	2	NUT, 3/8-16 ESN SS
6	3400455	2	SCREW, 3/8-16 X 1.50 HH SS
7	600114	2	SPACER, .328 B .498 OD .500 T
8	600363	1	WASHER, ISOLATOR
9	717030	2	BOLT, M8-1.25 X 20 HH SS
10	730339	1	NUT, M10-1.50 ESN SS
11	730506	2	BOLT, M8-125 X 30 HH SS
12	730508	1	BOLT, M6-1.00 X 35 HH full thread SS
13	730509	1	WELDMENT, VALVE BODY
14	730513	1	HANDLE, VALVE
15	730514	1	GATE, VALVE
16	730517	1	TUBE, DRAIN VALVE
17	730521	2	WASHER, NYLON, 5/8
18	730522	2	WASHER, NYLON, 1/2
19	730523	1	BAR, LEVER PIVOT
20	730524	1	ROD END, 3/8, MALE
21	730653	2	NUT, M6-1.00 SS
22	730716	1	MOUNT PLT, VALVE
23	730986	1	ASSEMBLY, DRAIN HOSE
24	731140	1	EDGING, 3/16 X 12.0"
25	731141	1	EDGING, 3/16 X 8.44"
26	731142	1	BOLT, M10-1.50 X 60 HH SS
27	731143	2	BOLT, 3/8-16 X .75 BUTTON HD CAP SS
28	731144	3	CLAMP, HOSE, 2.25 - 3.25
29	REF.	-	TANK, RECOVERY

PLASTIC HOPPER GROUP (730173)

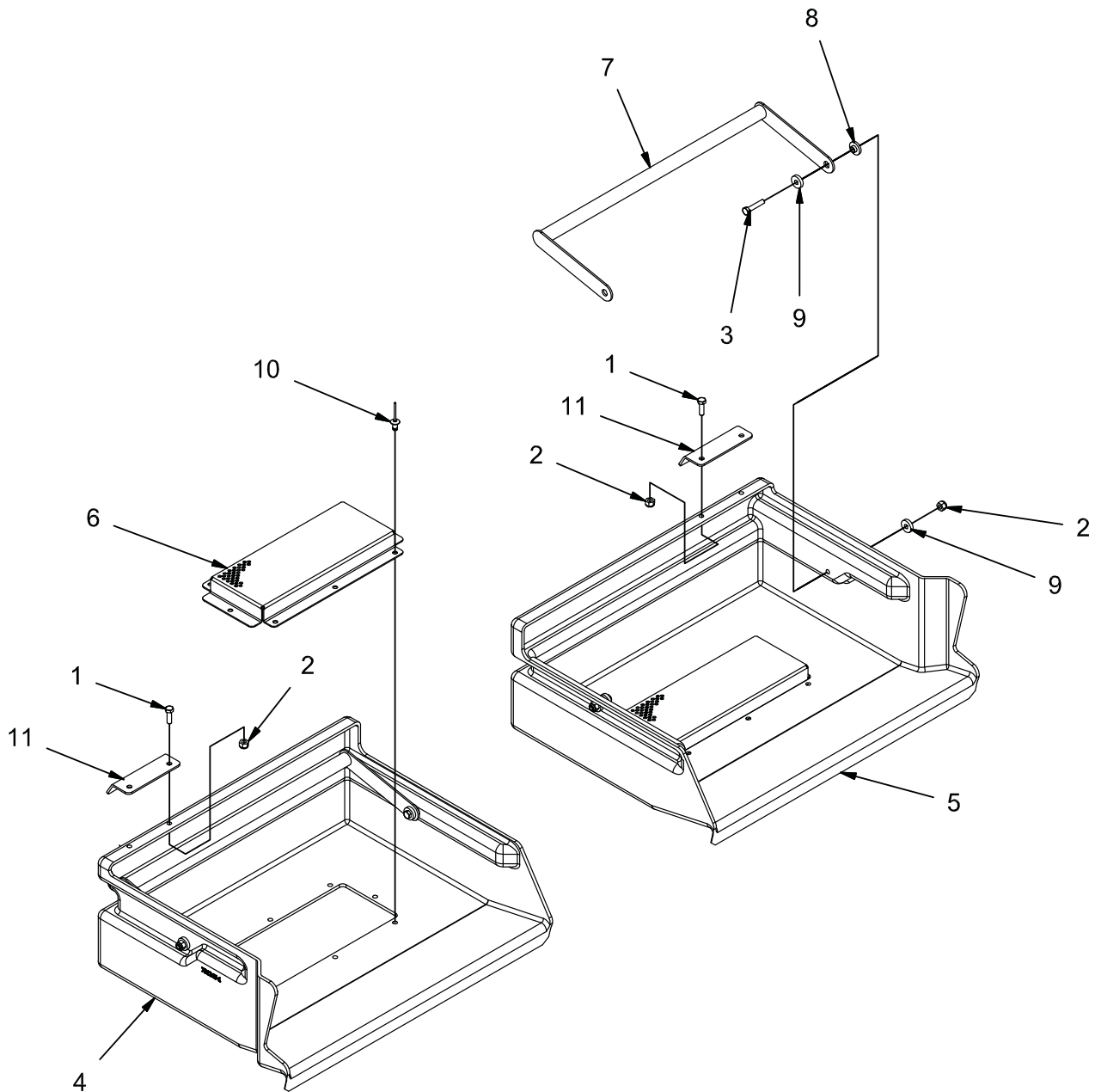

REV A

PLASTIC HOPPER GROUP (730173)

Parts List 730173			
ITEM	PART NUMBER	QTY	DESCRIPTION
1	600913	4	BOLT, M6-1.00 X 20 HH SS
2	600933	8	NUT, M6-1.00 ESN SS
3	731050	4	BOLT, M6-100 X 30 HH SS
4	731245-1	1	HOPPER, RIGHT
5	731246-1	1	HOPPER, LEFT
6	731247	2	SCREEN, HOPPER
7	731248	2	WELDMENT, HANDLE
8	731251	4	SPACER, PIVOT
9	731252	8	WASHER, THICK FENDER, M6, SS
10	731253	16	RIVET, BLIND, .25 D X .062 - .250 GRIP ALU
11	731368	2	RETAINER, HOPPER

HOPPER CRADLE GROUP (730174)

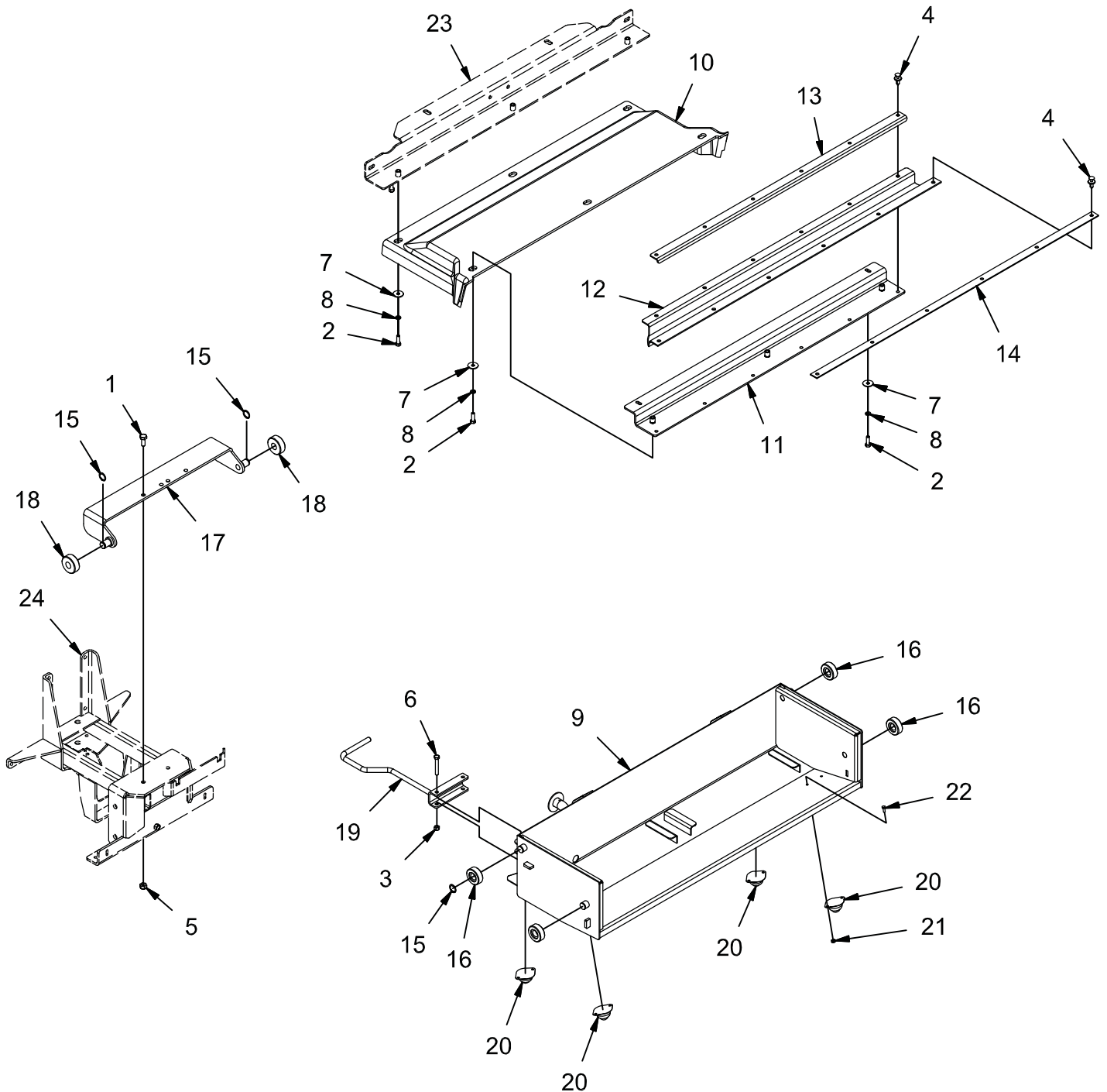

REV *

HOPPER CRADLE GROUP (730174)

Parts List 730124			
ITEM	PART NUMBER	QTY	DESCRIPTION
1	11038346	2	BOLT, M10-1.50 X 25 HH
2	11039567	8	BOLT, M8-1.25 X 25 HH SS
3	12040259	2	NUT, M8-1.25 ESN SS
4	600965	12	FASTENER, PRESS-IN
5	730339	2	NUT, M10-1.50 ESN SS
6	730507	2	BOLT, M8-1.25 X 55 HH SS
7	730526	8	WASHER, M8 FENDER SS
8	730527	8	LOCK WASHER, M8, SS
9	730807	1	WELDMENT, CRADLE
10	730825-1	1	COVER, HOPPER
11	730826-1	1	ASSEMBLY, COVER SUPPORT
12	730828	1	SEAL, HOPPER
13	730829	1	RETAINER, SEAL
14	730830	1	RETAINER, SEAL
15	730841	6	RETAINING RING, .75
16	730842	4	WHEEL
17	731133	1	WELDMENT, PUSH BRACKET
18	731136	2	ROLLER
19	731156-1	1	WELDMENT, CRADLE HANDLE
20	731239	4	BALL, ROLLER, 1" SS
21	731242	8	NUT, 10-32 ESN SS
22	731243	8	SCREW,#10-32 X .50 HH SS
23	REF	-	SUPPORT BEAM
24	REF.	-	SQUEEGEE LIFT

REAR BUMPER GROUP (730125)

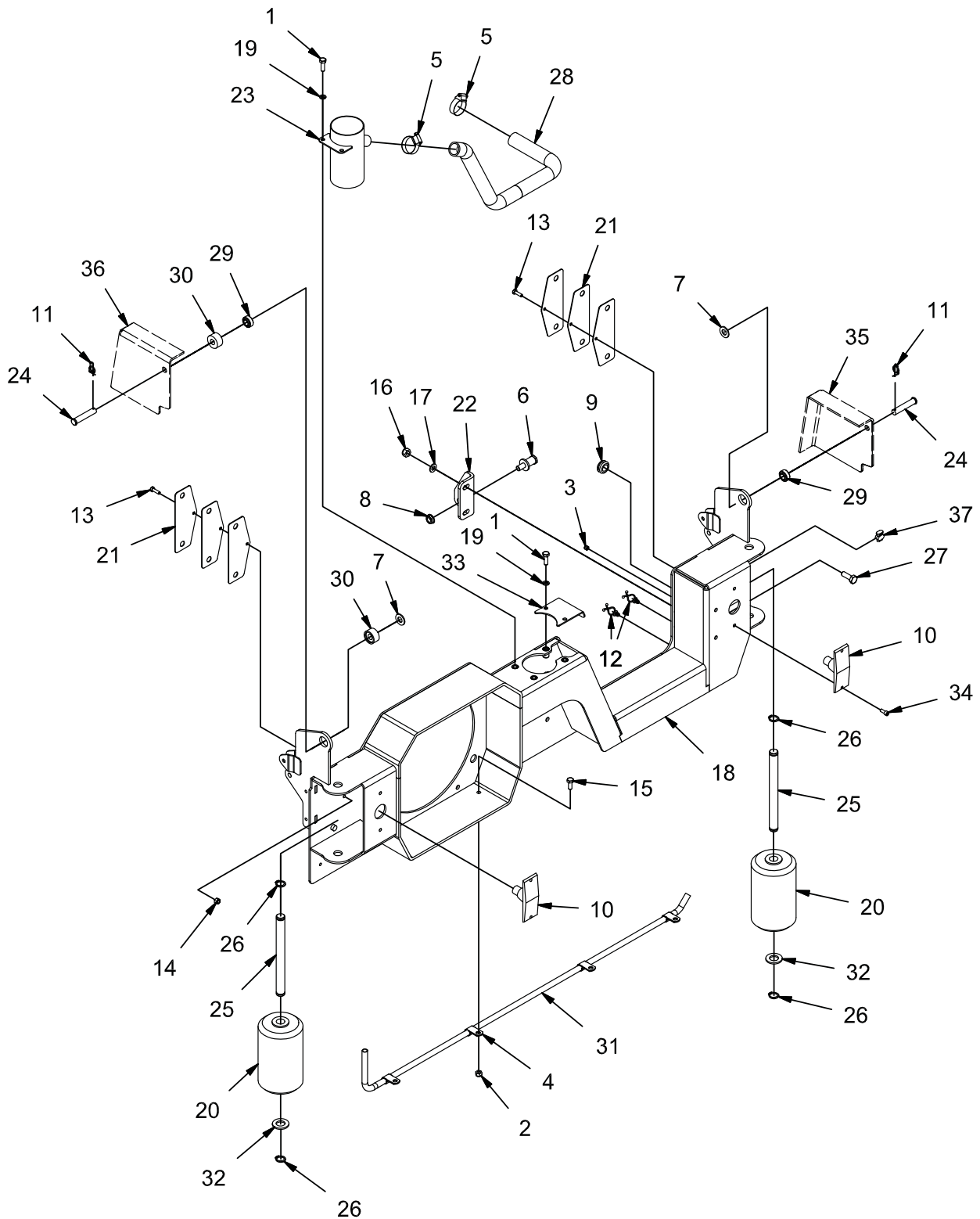

REV L

REAR BUMPER GROUP (730125)

Parts List 730125			
ITEM	PART NUMBER	QTY	DESCRIPTION
1	11039567	4	BOLT, M8-1.25 X 25 HH SS
2	12040259	4	NUT, M8-1.25 ESN SS
3	12040283	4	NUT, M5 - 0.8 ESN SS
4	3301158	4	CLAMP, .50 HOSE
5	3302193	2	CLAMP, HOSE, .75 - 1.25
6	3307248	1	STRIKER-LATCH
7	3400086	2	WASHER, 1/2, 1.063 X .531 X .094
8	3400394	1	NUT, 7/16-14 FLNG
9	600151	1	GROMMET, .63 ID .88 OD .25 T
10	600514-6	2	WIRE ASSY, TAIL LIGHT
11	600578	2	RUE-RING, .50
12	600581	2	CLAMP, WIRE CLIP
13	600913	2	BOLT, M6-1.00 X 20 HH SS
14	600933	2	NUT, M6-1.00 ESN SS
15	717030	4	BOLT, M8-1.25 X 20 HH SS
16	730339	2	NUT, M10-1.50 ESN SS
17	730344	2	WASHER, M10 SS
18	730360-1	1	ASSEMBLY, BUMPER
19	730527	4	LOCK WASHER, M8, SS
20	730719	2	ROLLER
21	730778	6	SHIM PLT
22	730789	1	STRIKER MNT LH
23	730868	1	WELDMENT, SQU TUBE
24	730875	2	PIN, CLEVIS 1/2 X 2.50 ZP
25	730876	2	PIN, ROLLER
26	730877	4	RETAINING RING, EXT, .750
27	730878	2	BOLT, M10-1.50 X 30 HH SS
28	730879	1	TUBING, HOPPER VAC
29	730882	2	BEARING, SPHERICAL
30	730883	2	SPACER, BUMPER
31	730885	1	TUBE, WIRE
32	730886	2	FLAT WASHER, .75 ZP
33	731189	1	COVER, HOSE PORT
34	831206	4	SCREW, M5-0.8 X 16 SHCS ZP
35	REF	-	FRAME
36	REF	-	FRAME
-	748982	1	HARNESS, LEFT TAIL LIGHT
-	748983	1	HARNESS, RIGHT TAIL LIGHT
37	742934	2	GROUND CONNECTOR, SEALED

BUMPER LIFT GROUP (730159)

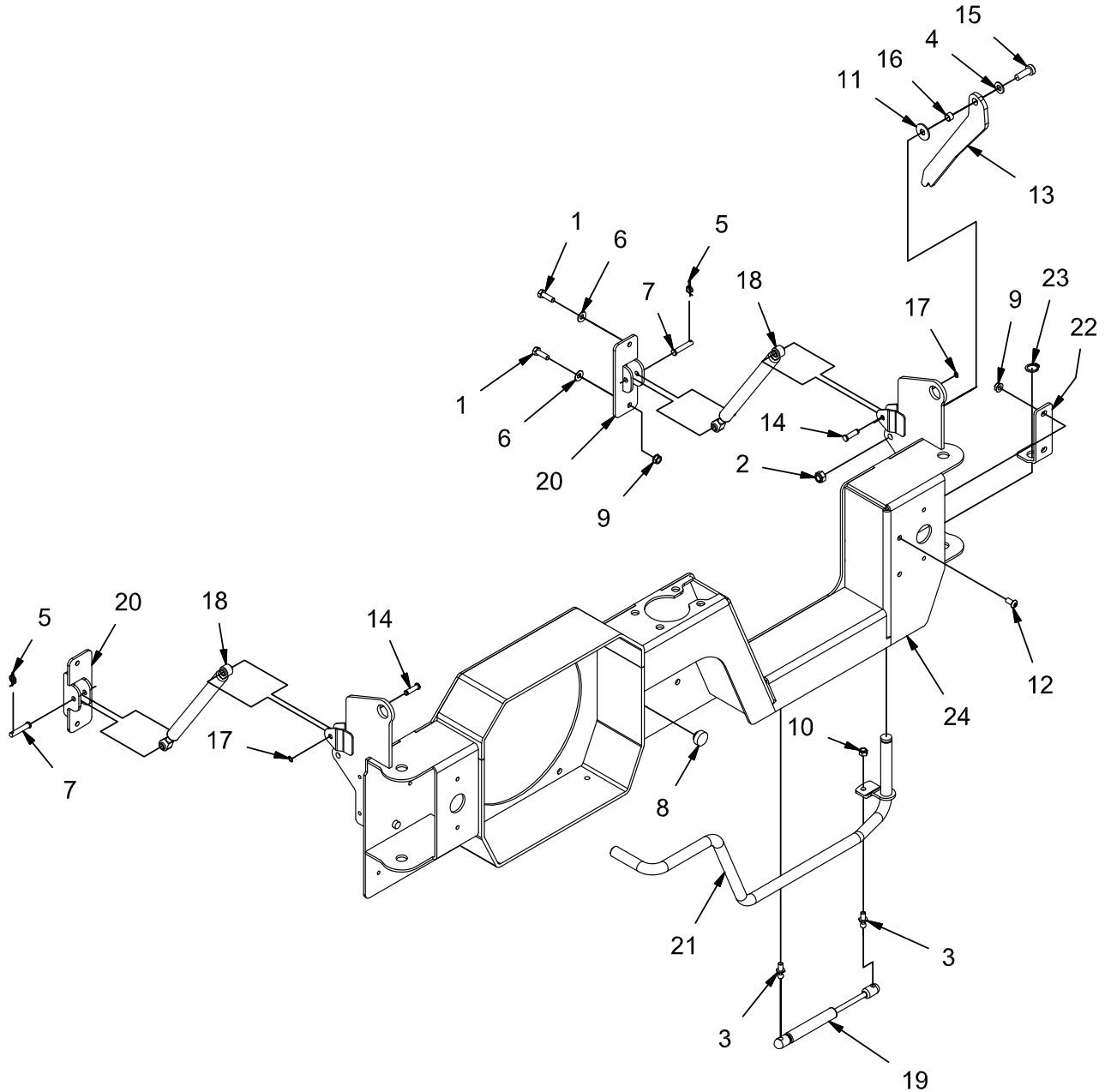

REV E

BUMPER LIFT GROUP (730159)

Parts List 730159			
ITEM	PART NUMBER	QTY	DESCRIPTION
1	11038247	4	BLT-HH M8-1.25 X 25 STL ZINC
2	12040069	1	NUT, M10-1.50 ESN
3	3300376	2	STUD, 10MM BALL
4	3400087	1	WASHER, 3/8
5	3400125	2	RUE-RING, .375
6	3400384	4	WASHER, 5/16 BELLEVILLE
7	3401982	2	PIN, CLEVIS, .313 X 1.625
8	600117	1	BUMPER, 1.00 X .339 T
9	600934	4	NUT, M8-1.25 FLNG
10	711374	2	NUT, FIBER INSERT 5/16-18
11	717040	1	WASHER, FENDER, .413 B 1.18 OD .098 T SS
12	730399	2	SCREW, M8-1.25 X 16 BUTTON HD CAP CZP
13	730758	1	SAFETY ARM
14	730779	2	PIN, BUMPER
15	730872	1	SCREW, M10-1.50 X 30 LOW PROFILE CAP SS
16	730873	1	SPACER, .406 B .498 OD .325 T
17	730874	2	RETAINING RING, EXT, .313
18	730887	2	GAS STRUT, 17.01 EXT 6.89 STK
19	730902	1	GAS STRUT, 8.8 EXT, 3.0 STK, 200N
20	730935	2	WELDMENT, STRUT MOUNT
21	731205	1	WELDMENT, BUMPER LEVER
22	731209	1	W/D, BUMPER, LEVER PIVOT
23	731212	1	RETAINING RING, EXT, HD .750
24	REF	-	REAR BUMPER

IMPELLER GROUP (730126)

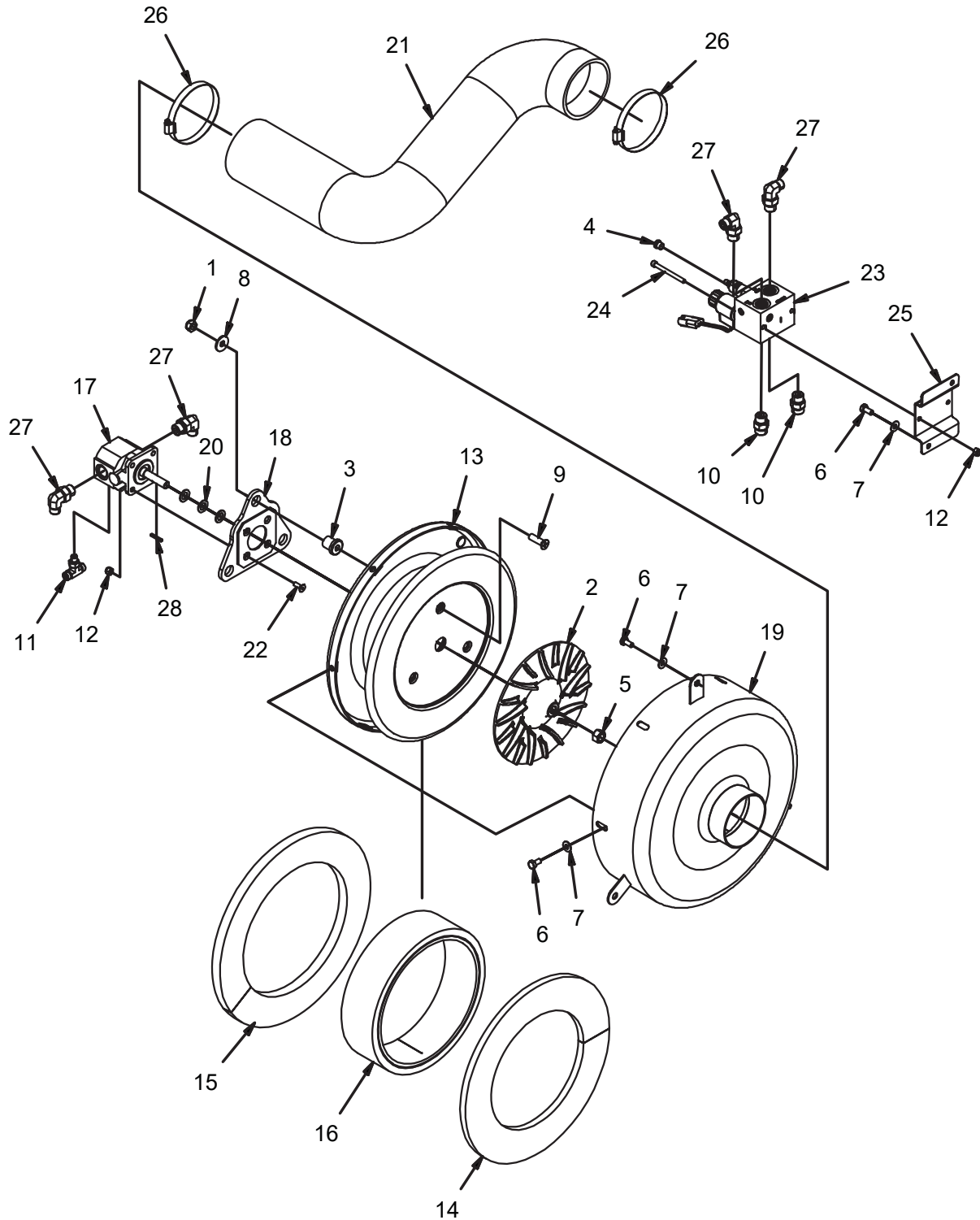

REV E

IMPELLER GROUP (730126)

Parts List 730126			
ITEM	PART NUMBER	QTY	DESCRIPTION
1	12040069	3	NUT, M10-1.50 ESN
2	3300133	1	IMPELLER
3	3300465	3	ISOLATOR, VIB
4	3331436	1	FITTING, PLUG, 4 O-RING
5	3400064	1	NUT, 1/2-20 UNF ZP
6	3400291	11	BOLT, M8-1.25 X 16 HH
7	3400384	11	WASHER, 5/16 BELLEVILLE
8	600363	3	WASHER, ISOLATOR
9	600954	3	SCREW, M10-1.50 X 35 FHMS
10	675524	2	FITTING, STR, -8 ORFS - 8 SAE
11	675556	1	FITTING, TEE, 4 ORFS - 4 SAE
12	711373	6	NUT, FIBER INSERT 1/4-20
13	730463-1	1	IMPELLER HOUSING, MACHINED
14	730466	1	INSULATION, SOUND
15	730467	1	INSULATION, SOUND
16	730468	1	INSULATION, SOUND
17	730470	1	MOTOR, HYD, GEAR
18	730471	1	WELDMENT, MOTOR MNT
19	730474	1	WELDMENT, IMPELLER SHROUD
20	730479	3	PRECISION WASHER, .88 D .51 B .060 T
21	730501	1	HOSE, VACUUM FAN
22	730562	4	SCREW, 1/4-20 X .750 FHMS ZP
23	730790	1	MANIFOLD, IMPELLER
24	730889	2	BOLT, 1/4-20 X 2.75 SOC HD ZP
25	730891	1	BRACKET, MANIFOLD
26	731166	2	CLAMP, HOSE, 3" - 4"
27	675520	4	FITTING, 90, 6 ORFS - 6 O-RING
28	PART OF 730470	1	KEY, .125 SQ X 1.00

IMPELLER HYDRAULIC MANIFOLD GROUP (730172)

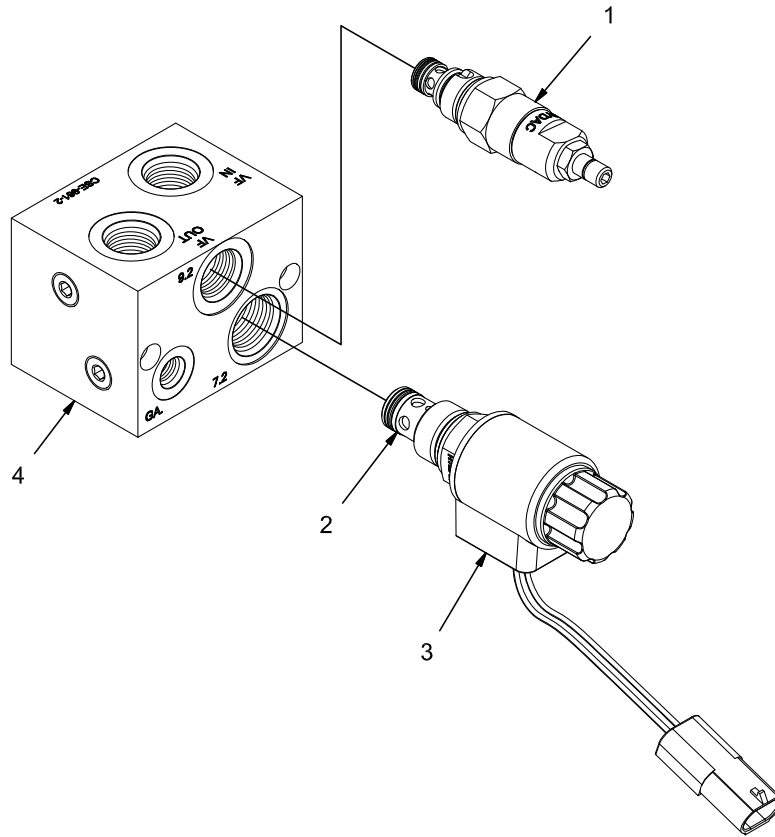

IMPELLER HYDRAULIC MANIFOLD GROUP (730172)

Parts List 730712			
ITEM	PART NUMBER	QTY	DESCRIPTION
1	730701	1	RELIEF VALVE, DB08P-01-C-N-330-V-250
2	730709	1	SOL. VALVE, WS10Y-01-C-N-0
3	731122	1	COIL, 12V, 3003124
4	731124	1	MANIFOLD BLOCK, IMP

HYDRAULIC RESERVOIR GROUP (730127)

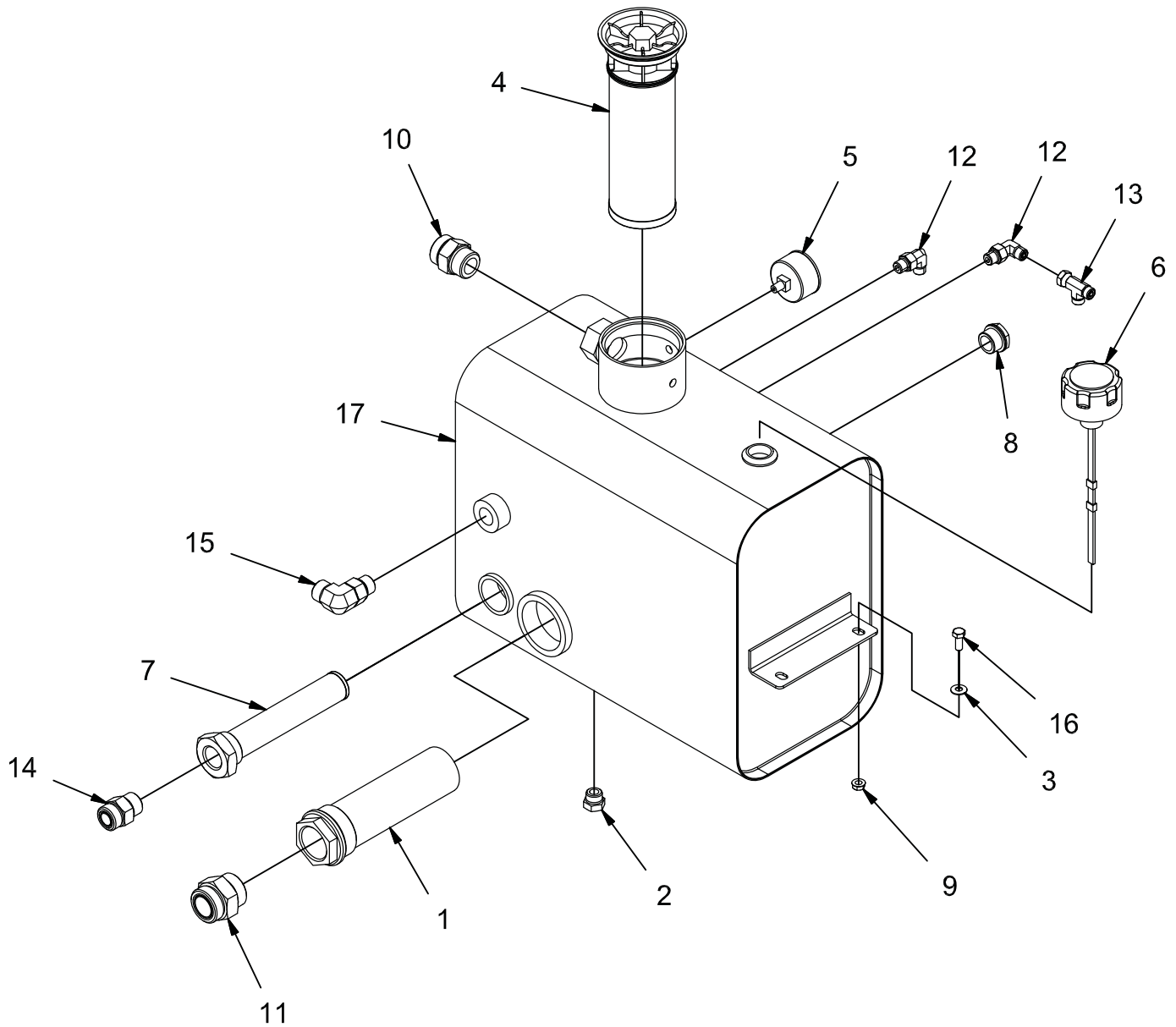

REV *

HYDRAULIC RESERVOIR GROUP (730127)

Parts List 730127			
ITEM	PART NUMBER	QTY	DESCRIPTION
1	3343836	1	STRAINER, HYDRAULIC, 20
2	3400164	1	FITTING, PLUG, 8 O-RING
3	3400384	4	WASHER, 5/16 BELLEVILLE
4	600182	1	FILTER ELEMENT, 10 MIC
5	600183	1	GAUGE, 0-60 PSI
6	600184	1	FILLER-BREATHER, 10 MIC
7	600185	1	STRAINER, 12
8	600531	1	SIGHT GAUGE
9	600934	4	NUT, M8-1.25 FLNG
10	675505	1	FITTING, STR, 16 ORFS - 16 SAE
11	675539	1	FITTING, STR, 20 ORFS - 20 SAE
12	675546	2	FITTING, 90, 4 ORFS - 6 SAE
13	675549	1	FITTING, RUN TEE, 4 ORFS - 4 SAE
14	675551	1	FITTING, STR, 12 ORFS - 12 SAE
15	675557	1	FITTING, 90, 10 ORFS - 10 SAE
16	717024	4	BOLT, M8-1.25 X 20 HH
17	730309	1	TANK, HYD RESERVOIR

HYDRAULIC PUMP GROUP (730136)

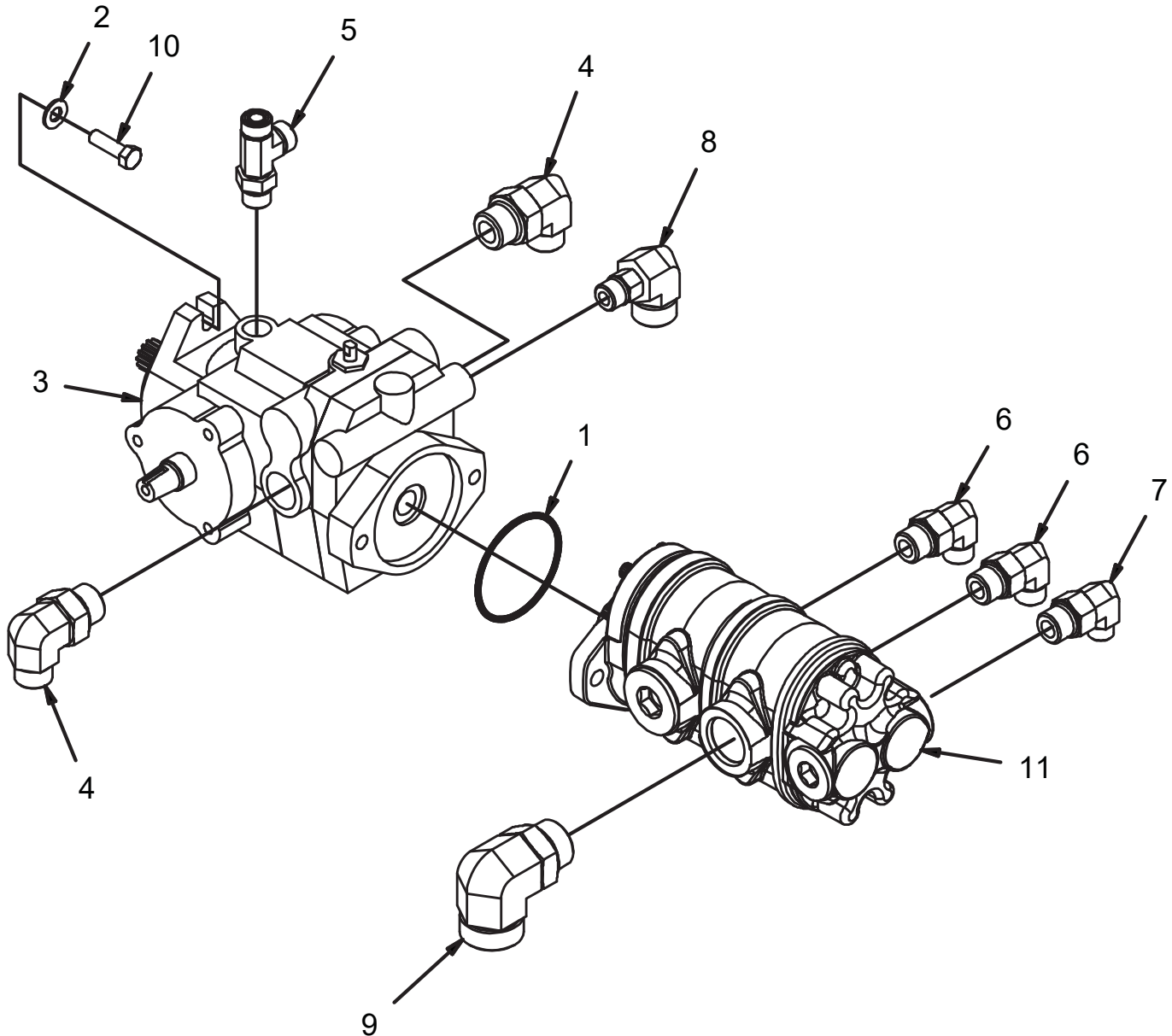

REV A

HYDRAULIC PUMP GROUP (730136)

Parts List - 730136			
ITEM	PART NUMBER	QTY	DESCRIPTION
1	3303711	1	O-RING
2	3400385	2	WASHER, 3/8, BELLEVILLE
3	600215	1	PUMP, PROPULSION
4	675500	2	FTG - ELBOW -10 ORFS TO -12 SAE
5	675525	1	FITTING, RUN TEE, 8 ORFS - 8 ORFS - 8 SAE
6	675528	2	FITTING, 90, -8 ORFS - 10 SAE
7	675532	1	FITTING, 90, 6 ORFS - 10 SAE
8	675543	1	FITTING, 90, 12 ORFS - 8 SAE
9	675553	1	FTG-STR THD 90 -20 ORFC TO -16 SAE
10	713043	2	SCREW, 3/8-16 X 1.25 HH
11	730310	1	PUMP, AUX

HYDRAULIC VALVE GROUP (730137)

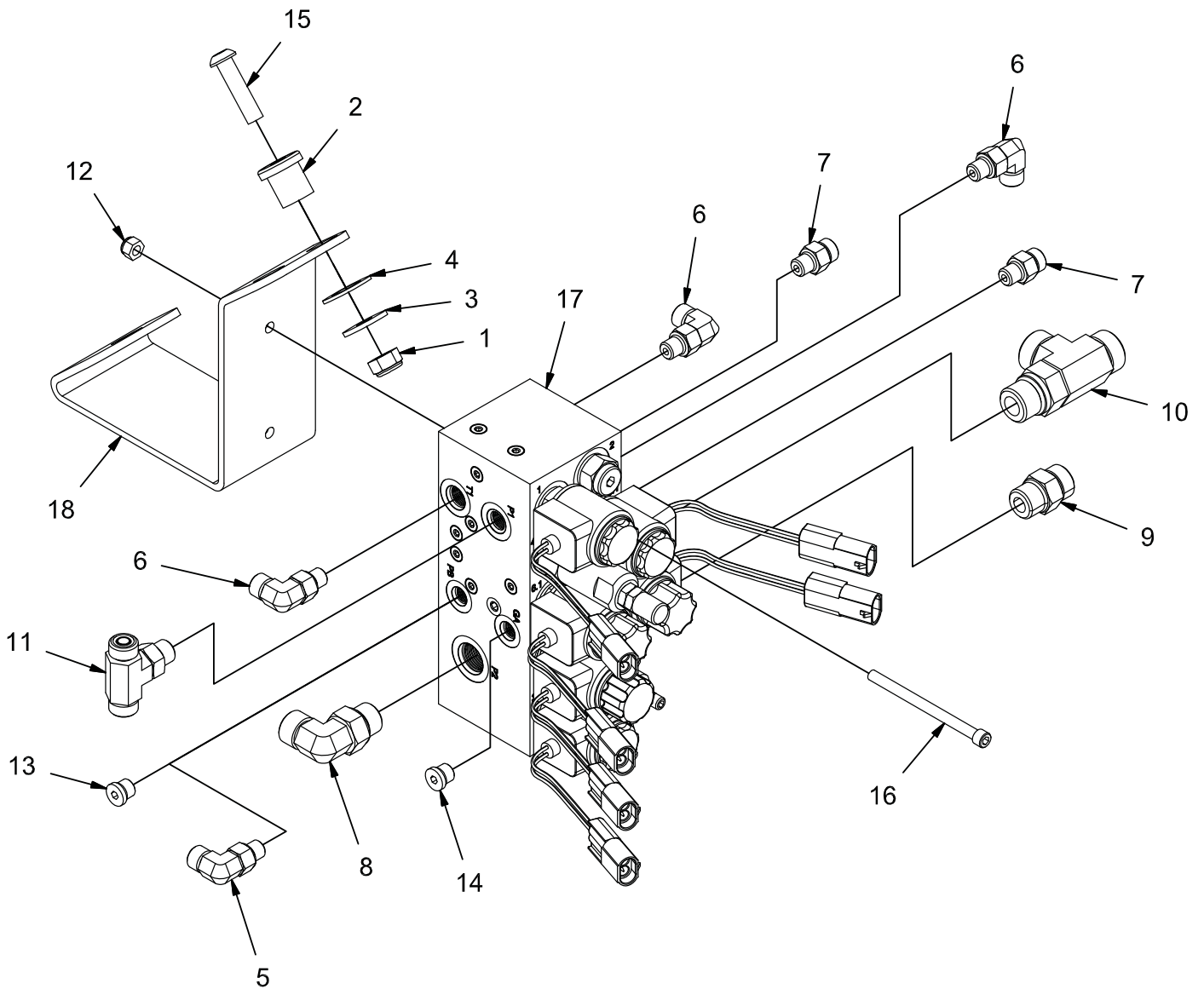

REV *

HYDRAULIC VALVE GROUP (730137)

Parts List 730137			
ITEM	PART NUMBER	QTY	DESCRIPTION
1	12040069	3	NUT, M10-1.50 ESN
2	3300465	3	ISOLATOR, VIB
3	600363	3	WASHER, ISOLATOR
4	66-431-A	3	WASHER, .77 B 1.25 OD .075 T
5	675507	1	FITTING, 90, 4 ORFS - 4 SAE (W/ OPT SIDE BRUSH)
6	675507	3	FITTING, 90, 4 ORFS - 4 SAE
7	675508	2	FITTING, STR, 4 ORFS - 4-SAE
8	675523	1	FITTING, 90, 8 ORFS - 8 SAE
9	675524	1	FITTING, STR, 8 ORFS - 8 SAE
10	675540	1	FITTING, RUN TEE, 10 ORFS - 10 SAE
11	675555	1	FITTING, TEE 6 ORFS - 6 SAE
12	711373	2	NUT, FIBER INSERT 1/4-20
13	3331436	1	FITTING, PLUG 4 O-RING (W/O OPT SIDE BRUSH)
14	3331436	1	FITTING, PLUG, 4 O-RING (GAUGE PORT)
15	730698	3	BOLT, M10-1.50 X 40 BUTTON HD CAP
16	730699	2	BOLT, 1/4-20 X 3.50 SOC HD CAP
17	730700	1	HYDRAULIC MANIFOLD ASSEMBLY
18	730711	1	MOUNT, MANIFOLD

HYDRAULIC MANIFOLD COMPONENTS GROUP (730170)

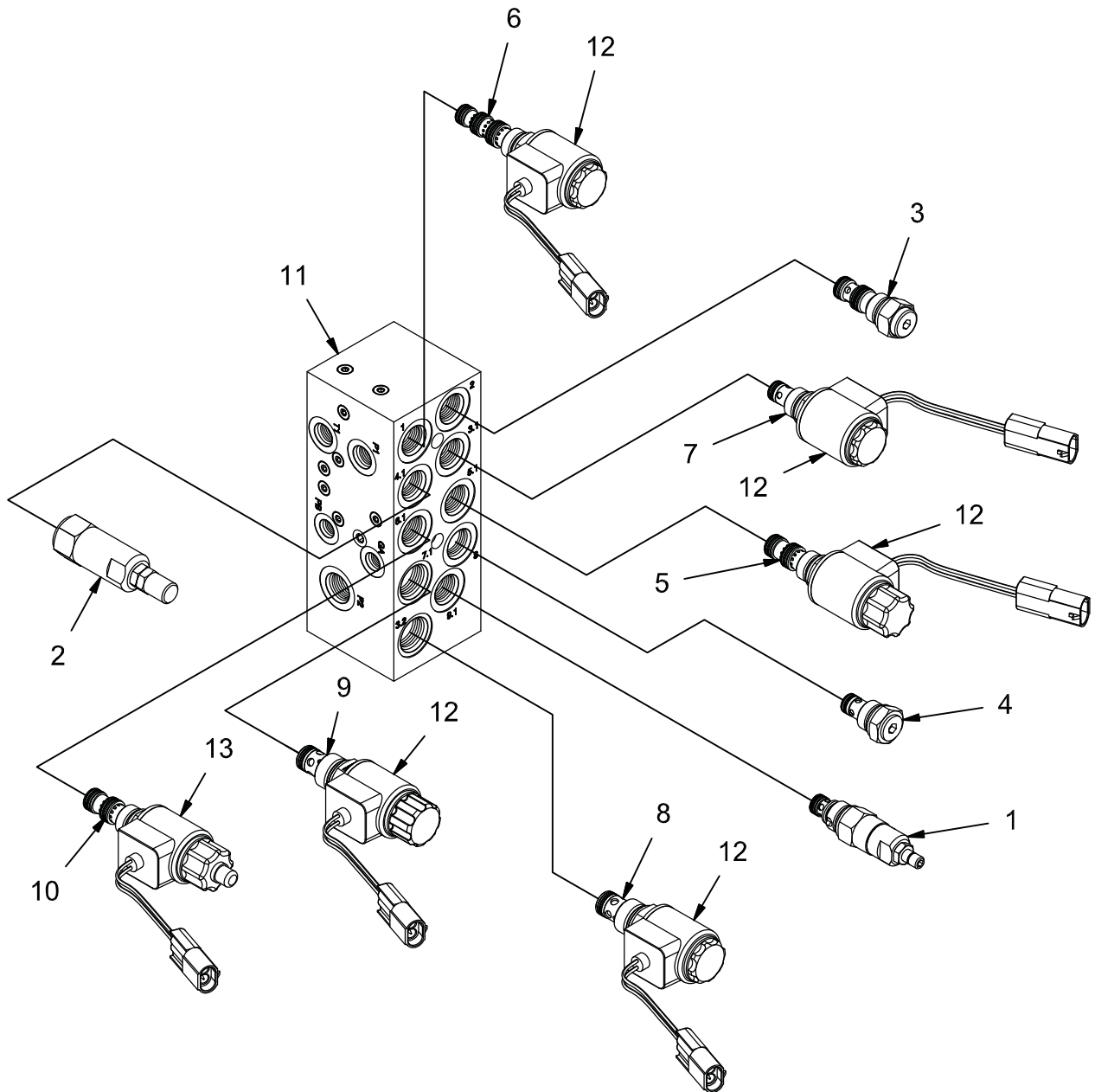

REV B

HYDRAULIC MANIFOLD COMPONENTS GROUP (730170)

Parts List 730170			
ITEM	PART NUMBER	QTY	DESCRIPTION
1	730701	1	PORT 9.1 - RV2 - RELIEF VALVE RELIEF VALVE, DB08P-01-C-N-330-V-250
2	730702	1	PORT 4.1 - RV3 - PRESSURE REDUCTION VALVE SOL. RED. VALVE, DR08-01-C-N-050-V-45
3	730703	1	PORT 2 - CV2 - P.O. CHECK VALVE P.O. CHECK VALVE, RP08A-01-C-N-15-4
4	730704	1	PORT 8 - CV1 - CHECK VALVE CHECK VALVE, RV08A-01-C-N-05
5	730705	1	PORT 5.1 - SV5 - MAIN BRUSHES DOWN SOL. VALVE, WK08L-01-C-N-0
6	730706	1	PORT 1 - SV7 - SQUEEGEE UP-DN SOL. VALVE, WK08X-01-C-N-0
7	730707	1	PORT 3.1 - SV6 - MAIN BRUSHES UP-LOCK SOL. VALVE, WS08ZR-01-C-N-0
8	730708	1	PORT 3.2 - SV3 - MAIN BRUSHES ON-OFF SOL. VALVE, WS10ZR-01-C-N-0
9	730709	1	PORT 7.1 - SV2 - ALL OFF SOL. VALVE, WS10Y-01-C-N-0
10	730710	1	PORT 6.1 - SV4 - BRUSH FORCE PROP. RED. VALVE, PDR08-01-M-C-N-070
11	731121	1	MANIFOLD BLOCK, MAIN C961-1
12	731122	5	COIL, 12V, 3003124
13	731226	1	COIL, PROPORTIONAL, 12PL-2.2-40-1836

ENGINE MOUNT GROUP - DIESEL (730128)

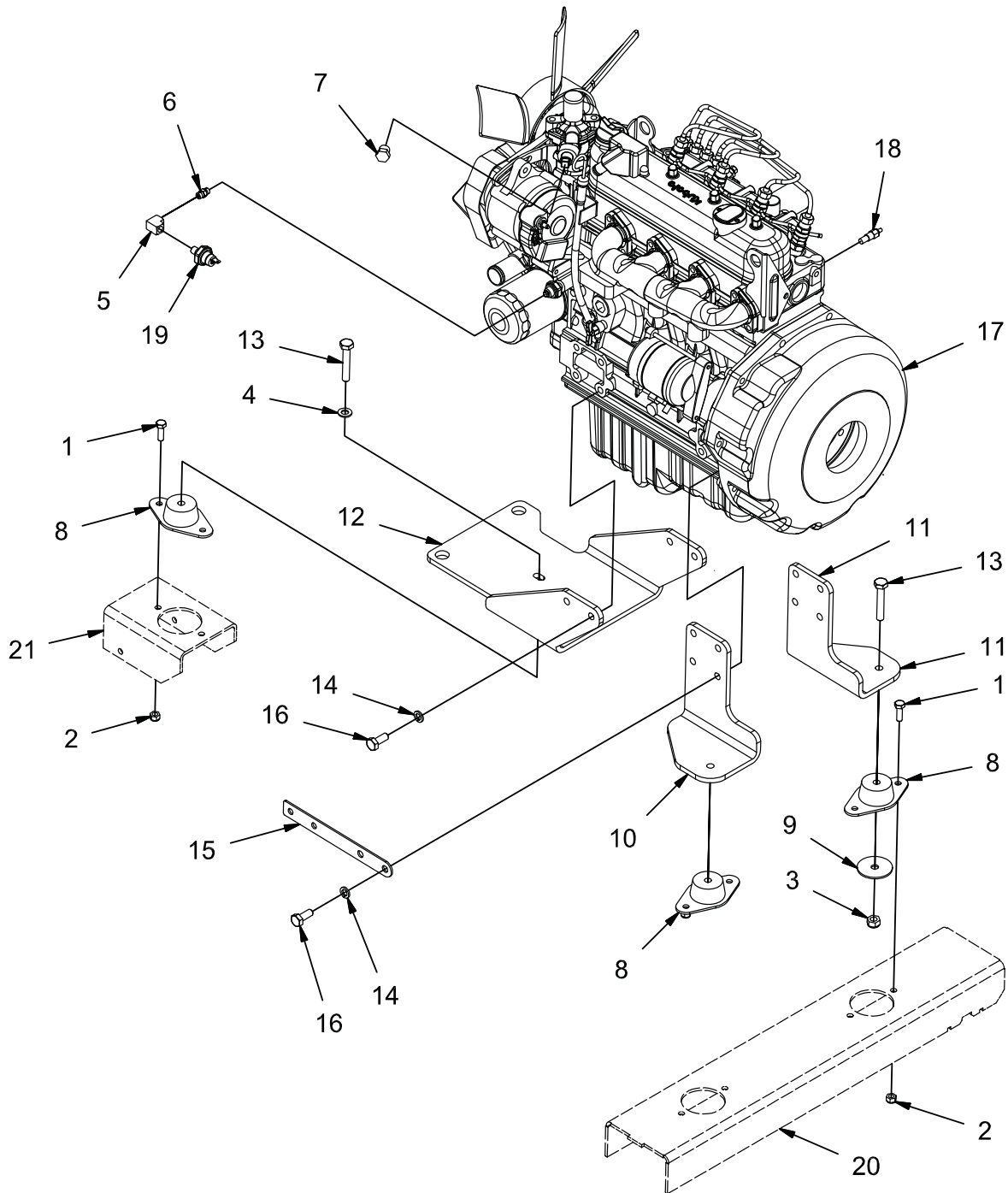

REV *

ENGINE MOUNT GROUP - DIESEL (730128)

Parts List 730128			
ITEM	PART NUMBER	QTY	DESCRIPTION
1	11038247	6	BLT-HH M8-1.25 X 25 STL ZINC
2	12040051	6	NUT, M8-1.25 ESN
3	12040069	3	NUT, M10-1.50 ESN
4	12310058	1	WASHER, M10
5	3301720	1	FTG, BRASS ELBOW, 1/8 FEMALE NPT
6	3305640	1	FITTING, NIPPLE
7	3400194	1	PIPE PLUG, BRASS, 3/8
8	600212	3	ISOLATOR, VIBRATION
9	600333	3	WASHER, SAFETY
10	600881	1	MOUNT, REAR OUTER DIESEL ENG
11	600882	1	MOUNT, REAR INNER DIESEL ENG
12	600899	1	MOUNT, FRONT DIESEL ENG
13	600925	3	BOLT, M10-1.50 X 60 HH
14	600945	12	LOCK WASHER, M10
15	620081	1	MOUNT, HARNESS
16	620082	12	BOLT, M10-1.25 X 25 HH ZP
17	620234	1	ENGINE, DSL, KUBOTA V1505
18	PART OF 620234	1	SWITCH, WATER TEMP (603000)
19	PART OF 620234	1	SWITCH, OIL PRESSURE (603001)
20	REF.	-	FRAME
21	REF.	-	FRAME

ENGINE MOUNT GROUP - GAS (730164)

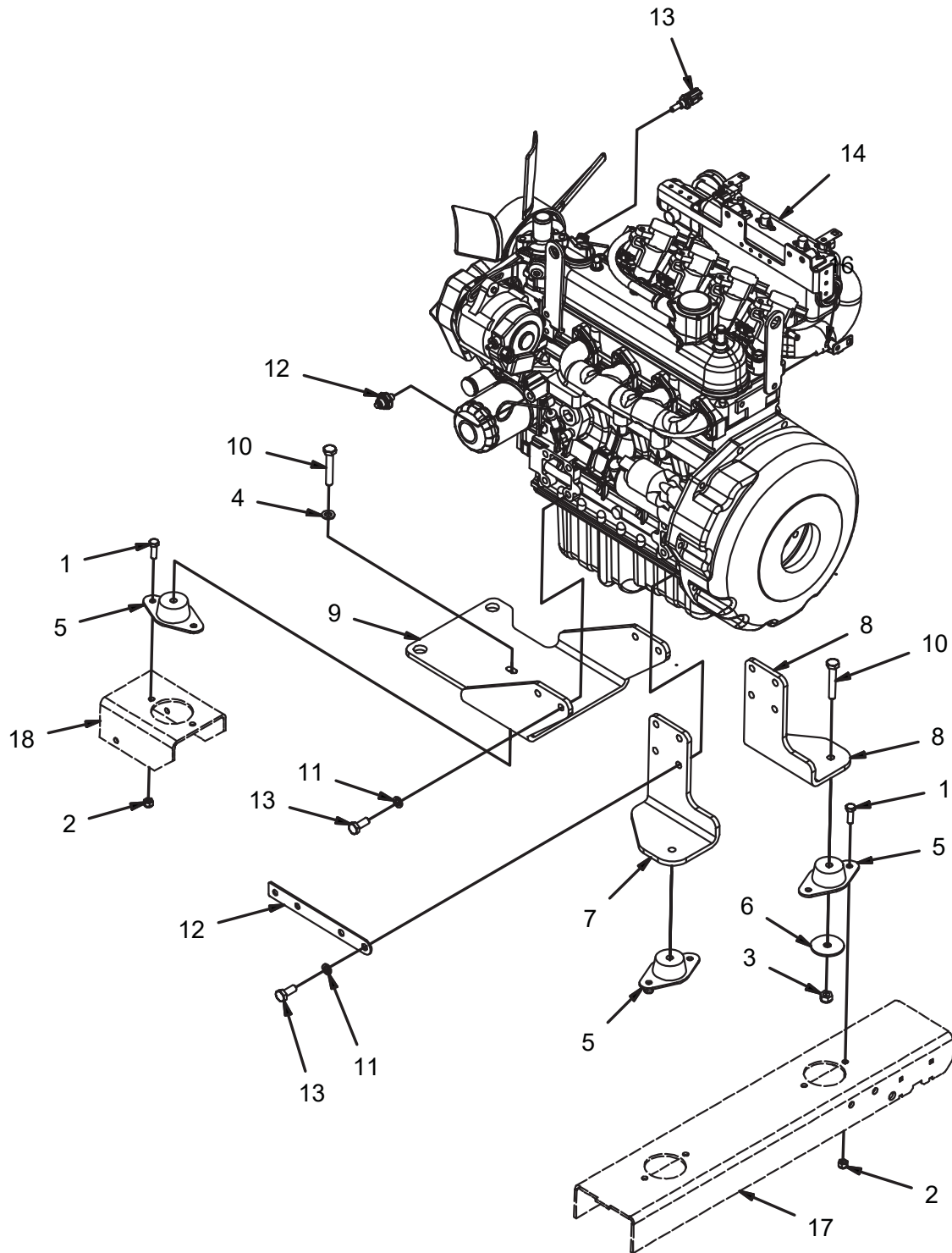

REV A

ENGINE MOUNT GROUP - GAS (730164)

Parts List 730164			
ITEM	PART NUMBER	QTY	DESCRIPTION
1	11038247	6	BLT-HH M8-1.25 X 25 STL ZINC
2	12040051	6	NUT, M8-1.25 ESN
3	12040069	3	NUT, M10-1.50 ESN
4	12310058	1	WASHER, M10
5	600212	3	ISOLATOR, VIBRATION
6	600333	3	WASHER, SAFETY
7	600881	1	MOUNT, REAR OUTER DIESEL ENG
8	600882	1	MOUNT, REAR INNER DIESEL ENG
9	600899	1	MOUNT, FRONT DIESEL ENG
10	600925	3	BOLT, M10-1.50 X 60 HH
11	600945	12	LOCK WASHER, M10
12	620081	1	MOUNT, HARNESS
13	620082	12	BOLT, M10-1.25 X 25 HH ZP
14	620700	1	KUBOTA GAS ENGINE
15	PART OF 620236	1	SWITCH, OIL PRESSURE (603001)
16	PART OF 620236	1	SWITCH, WATER TEMP (603000)
17	REF.	-	FRAME
18	REF.	-	FRAME

ENGINE MOUNT GROUP - LPG (730163)

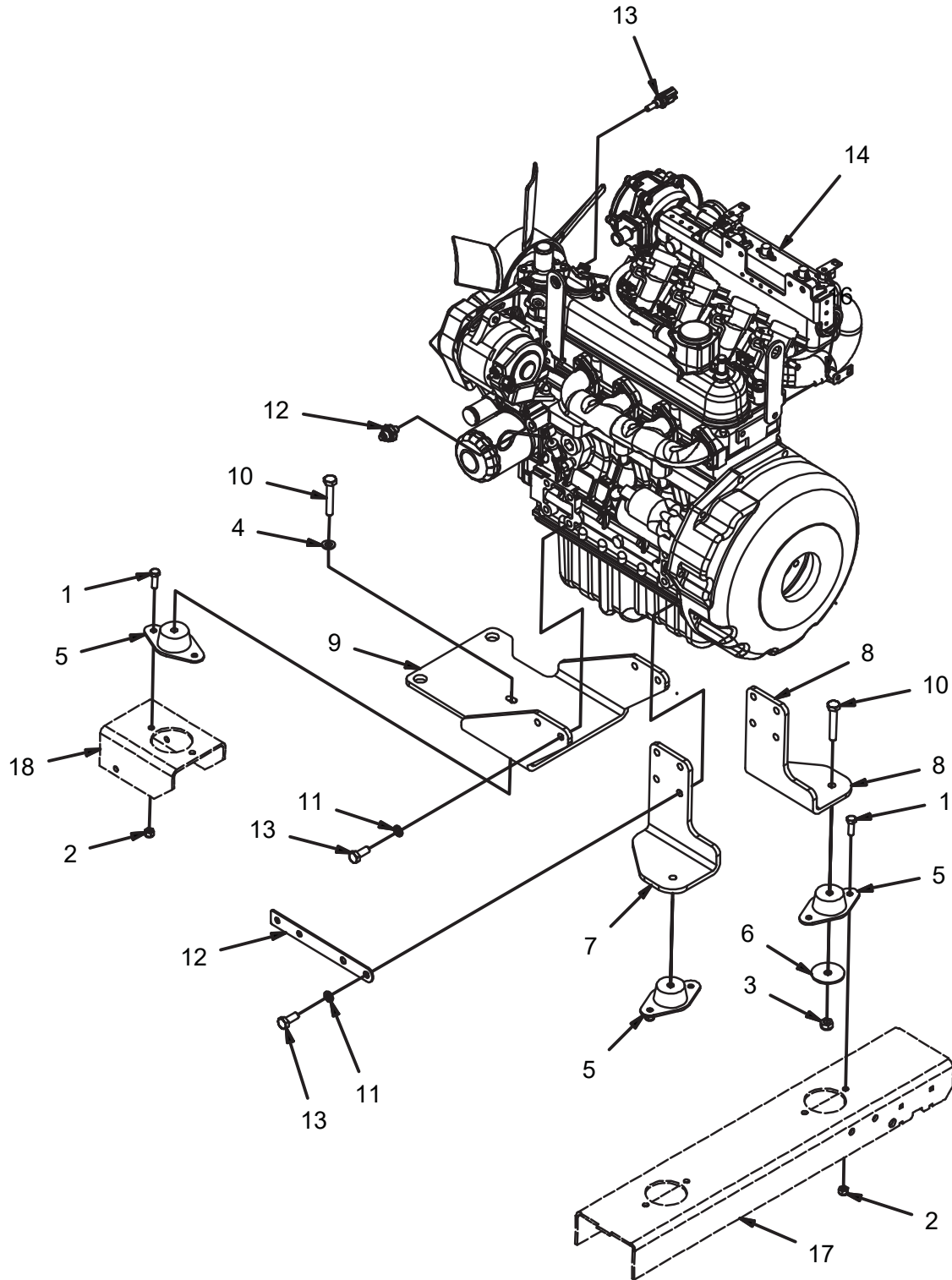

REV A

ENGINE MOUNT GROUP - LPG (730163)

Parts List 730163			
ITEM	PART NUMBER	QTY	DESCRIPTION
1	11038247	6	BLT-HH M8-1.25 X 25 STL ZINC
2	12040051	6	NUT, M8-1.25 ESN
3	12040069	3	NUT, M10-1.50 ESN
4	12310058	1	WASHER, M10
5	600212	3	ISOLATOR, VIBRATION
6	600333	3	WASHER, SAFETY
7	600881	1	MOUNT, REAR OUTER DIESEL ENG
8	600882	1	MOUNT, REAR INNER DIESEL ENG
9	600899	1	MOUNT, FRONT DIESEL ENG
10	600925	3	BOLT, M10-1.50 X 60 HH
11	600945	12	LOCK WASHER, M10
12	620081	1	MOUNT, HARNESS
13	620082	12	BOLT, M10-1.25 X 25 HH ZP
14	620699	1	KUBOTA ENGINE - LPG A/N (CAT MUFFLER)
15	PART OF 620235	1	SWITCH, OIL PRESSURE (603001)
16	PART OF 620235	1	SWITCH, WATER TEMP (603000)
17	REF.	-	FRAME
18	REF.	-	FRAME

AIR CLEANER GROUP - DIESEL (730131)

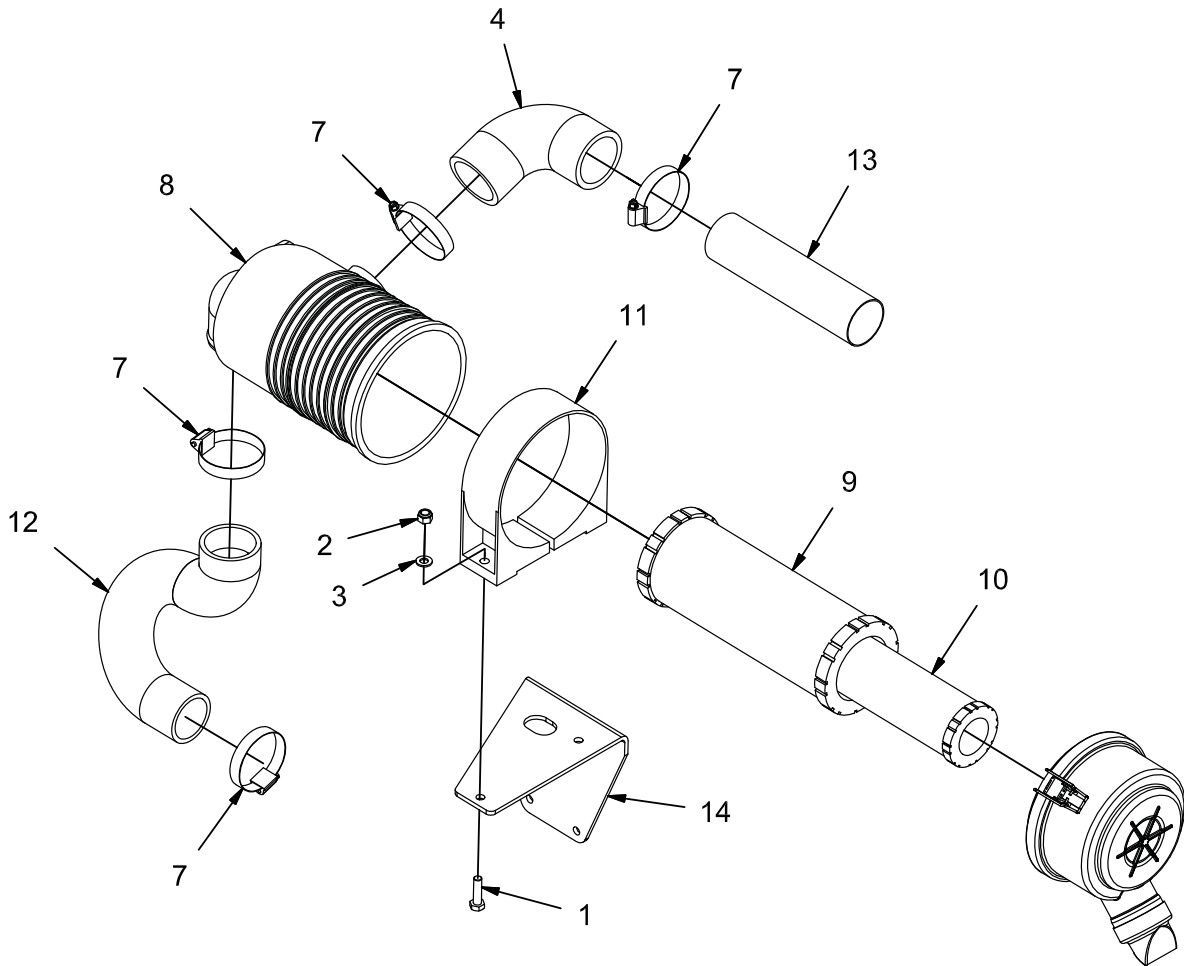

REV A

AIR CLEANER GROUP - DIESEL (730131)

Parts List 730131			
ITEM	PART NUMBER	QTY	DESCRIPTION
1	11038254	2	BOLT, M8-125 X 30 HH
2	12040051	2	NUT, M8-1.25 ESN
3	12310041	2	WASHER, M8
4	3300396	1	ADAPTER, 2" 90
5	3303991	1	INDICATOR, FLTR SERVICE
6	3305640	1	FITTING, NIPPLE
7	3312189	4	CLAMP, HOSE, 2.00
8	3317917	1	HOUSING, AIR FLTR
9	3321143	1	ELEMENT, FLTR, PRIMARY
10	3322572	1	ELEMENT, FLTR, SAFETY
11	600385	1	MOUNTING BAND, AIR CLEANER
12	730319	1	HOSE, AIR INTAKE, DIESEL
13	730393	1	TUBE, AIR CLEANER INTAKE
14	731188	1	MOUNT, AIR CLEANER

AIR CLEANER GROUP - GAS (730129)

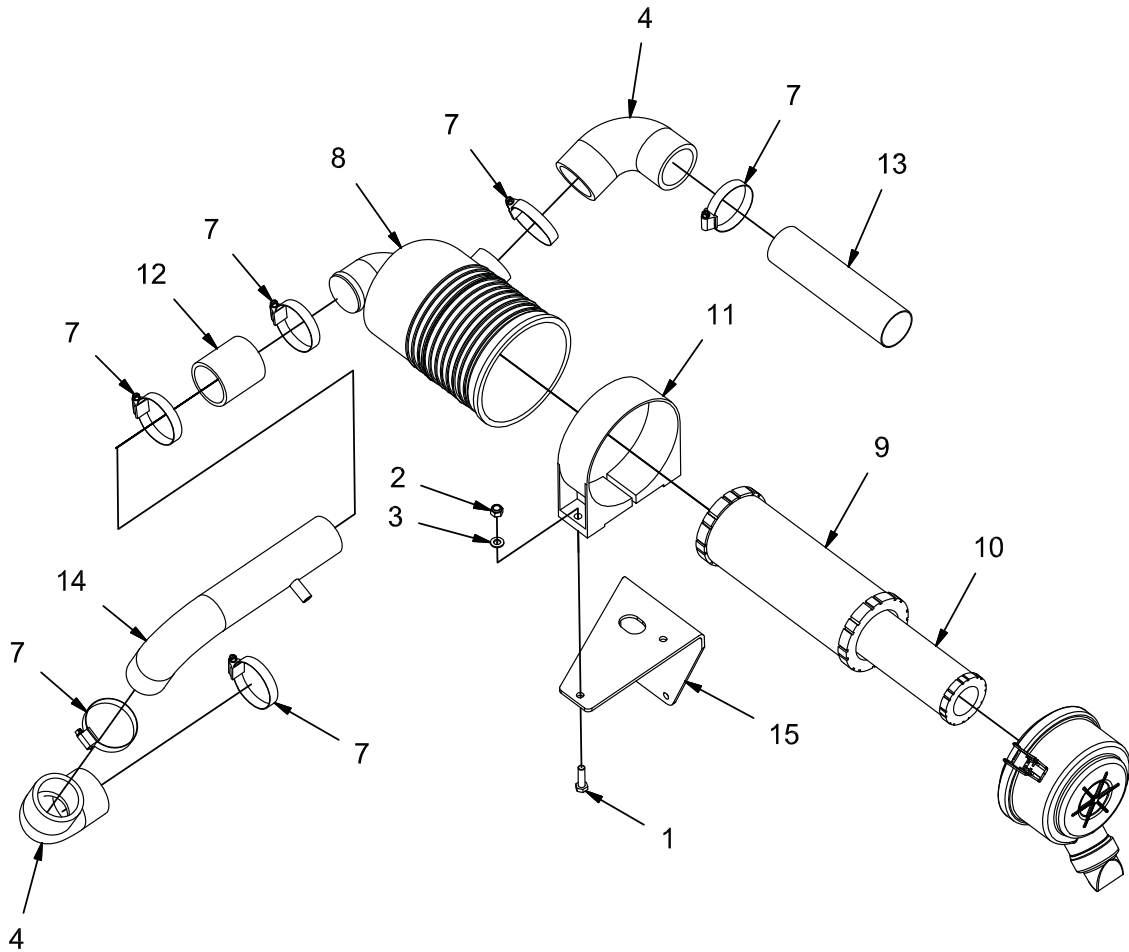

REV B

AIR CLEANER GROUP - GAS (730129)

Parts List 730129			
ITEM	PART NUMBER	QTY	DESCRIPTION
1	11038254	2	BOLT, M8-125 X 30 HH
2	12040051	2	NUT, M8-1.25 ESN
3	12310041	2	WASHER, M8
4	3300396	2	ADAPTER, 2" 90
5	3303991	1	INDICATOR, FLTR SERVICE
6	3305640	1	FITTING, NIPPLE
7	3312189	6	CLAMP, HOSE, 2.00
8	3317917	1	HOUSING, AIR FLTR
9	3321143	1	ELEMENT, FLTR, PRIMARY
10	3322572	1	ELEMENT, FLTR, SAFETY
11	600385	1	MOUNTING BAND, AIR CLEANER
12	600580	1	HOSE, 2.00 X 2.50
13	730393	1	TUBE, AIR CLEANER INTAKE
14	731110	1	WELDMENT, GAS AIR INTAKE
15	731188	1	MOUNT, AIR CLEANER

AIR CLEANER GROUP - LPG (730130)

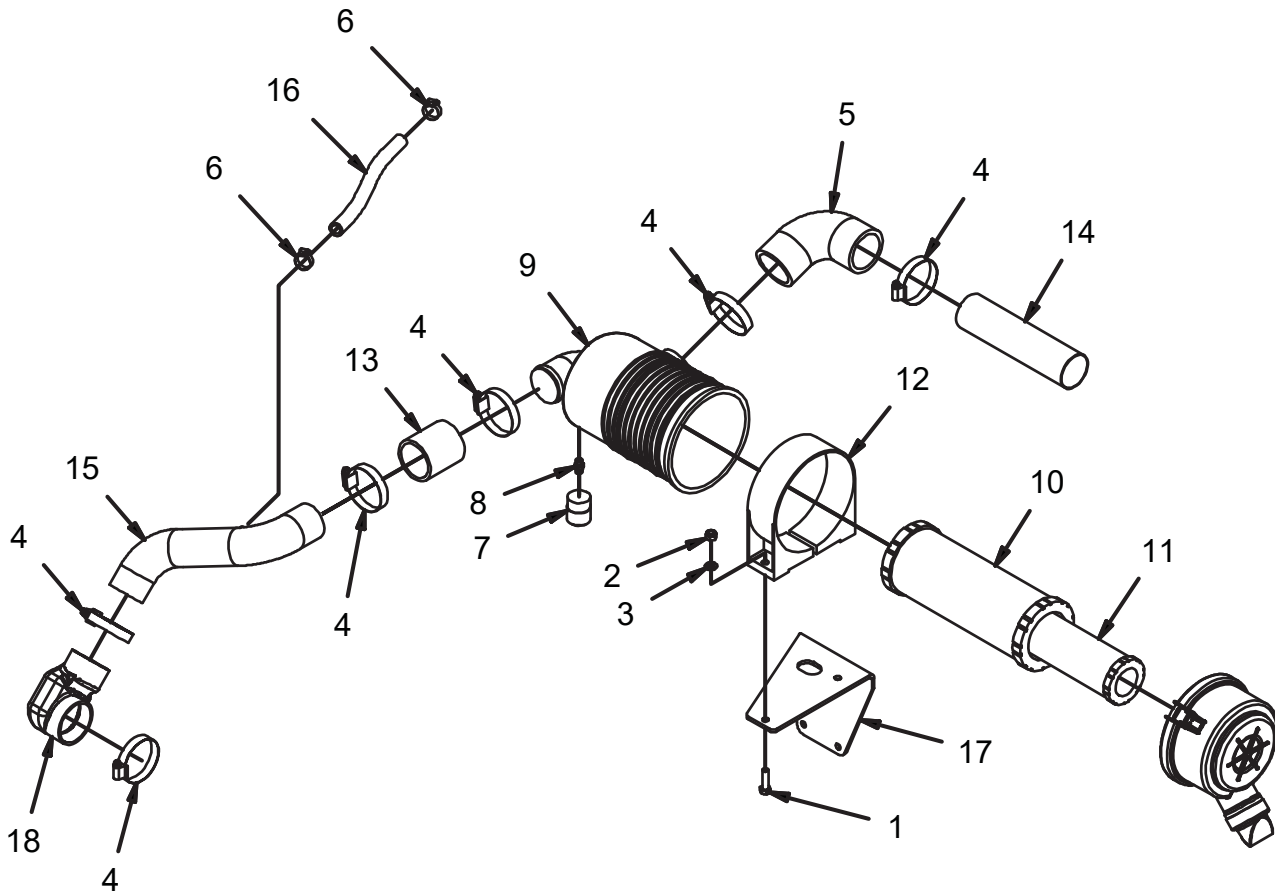

REV C

AIR CLEANER GROUP - LPG (730130)

Parts List 730130			
ITEM	PART NUMBER	QTY	DESCRIPTION
1	11038254	2	BOLT, M8-125 X 30 HH
2	12040051	2	NUT, M8-1.25 ESN
3	12310041	2	WASHER, M8
4	3044112	6	CLAMP, HOSE
5	3300396	1	ADAPTER, 2" 90
6	3300535	2	CLAMP, HOSE, .50
7	3303991	1	INDICATOR, FLTR SERVICE (INCLUDES 3305640)
8	3305640	1	FITTING, NIPPLE (SERVICE PART)
9	3317917	1	HOUSING, AIR FLTR (INCLUDES FILTER ELEMENTS)
10	3321143	1	ELEMENT, FLTR, PRIMARY (SERVICE PART)
11	3322572	1	ELEMENT, FLTR, SAFETY (SERVICE PART)
12	600385	1	MOUNTING BAND, AIR CLEANER
13	600580	1	HOSE, 2.00 X 2.50
14	730393	1	TUBE, AIR CLEANER INTAKE
15	731128	1	WELDMENT, LPG AIR INTAKE
16	731175	1	PCV HOSE
17	731188	1	MOUNT, AIR CLEANER
18	PART OF ENGINE	1	COBRA AIR CUFF

RADIATOR GROUP (730132)

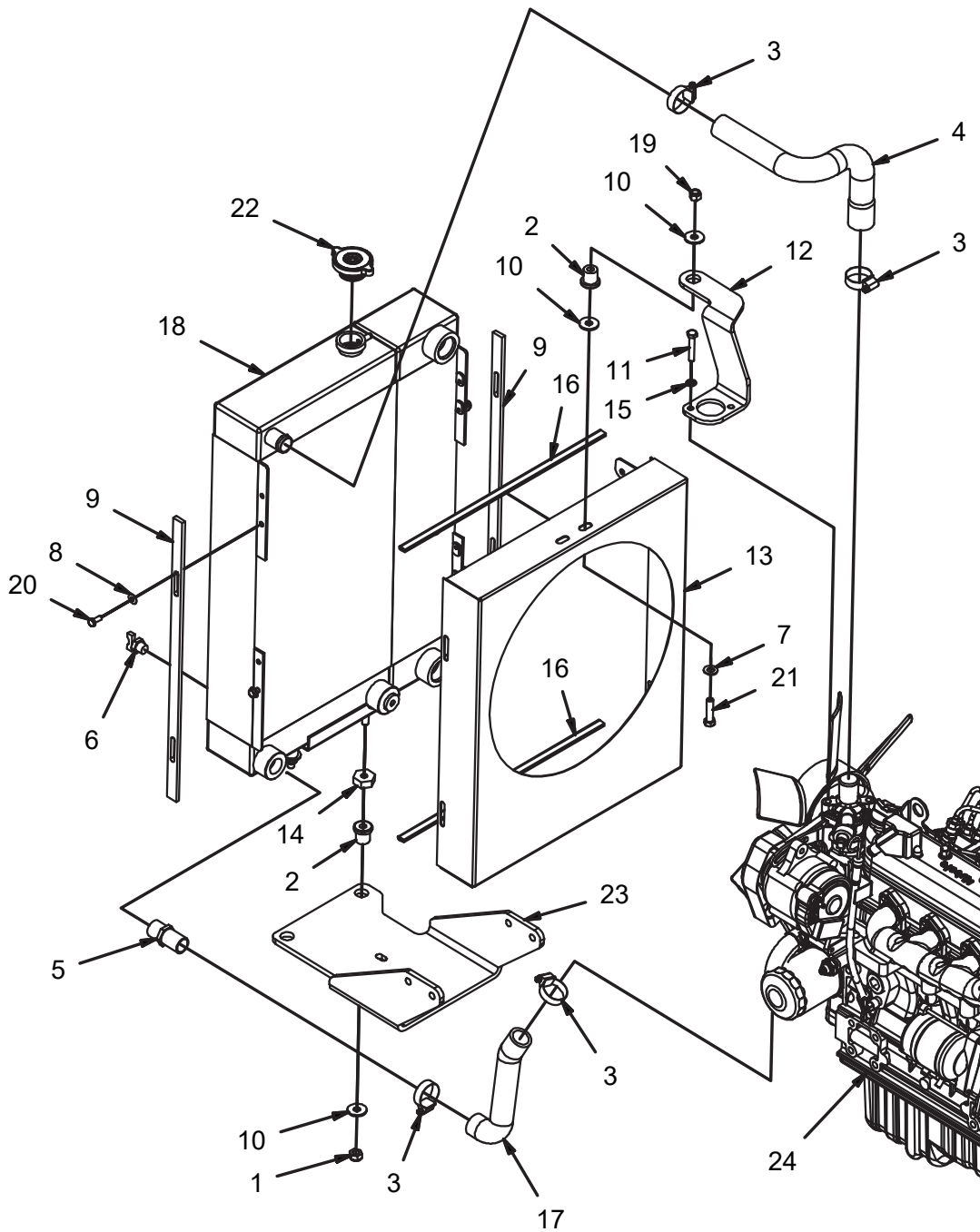

REV C

RADIATOR GROUP (730132)

Parts List 730132			
ITEM	PART NUMBER	QTY	DESCRIPTION
1	12040069	2	NUT, M10-1.50 ESN
2	3300465	3	ISOLATOR, VIB
3	3302193	4	CLAMP, HOSE, .75 - 1.25
4	3332643	1	HOSE, UPPER RAD, DIESEL
5	3333489	1	FTG-RAD (HOSE PORT 3336103)
6	3344232	1	PETCOCK
7	3400087	1	WASHER, 3/8
8	3400383	4	WASHER, 1/4 BELLEVILLE
9	600198	2	SPACER, SHROUD
10	600363	4	WASHER, ISOLATOR
11	600820	2	BOLT, M8-1.25 X 45 HH
12	600867	1	MOUNT, UPPER SHROUD, DIESEL
13	600875	1	WELDMENT, FAN SHROUD, DIESEL
14	600884	2	SPACER, ISOLATOR
15	600959	2	LOCK WASHER, M8
16	620064	2	SEAL, SHROUD
17	690020	1	HOSE, LOWER RADIATOR
18	690125	1	RADIATOR - OIL COOLER
19	711380	1	NUT, FIBER INSERT 3/8-16
20	713001	4	SCREW, 1/4-20 X .625 HHC
21	713044	1	SCREW, 3/8-16 X 1.50 HHC
22	PART OF 3336679	1	RADIATOR CAP
23	REF	-	FRONT ENGINE MOUNT
24	REF.	-	ENGINE, DIESEL

RADIATOR OVERFLOW BOTTLE GROUP (730133)

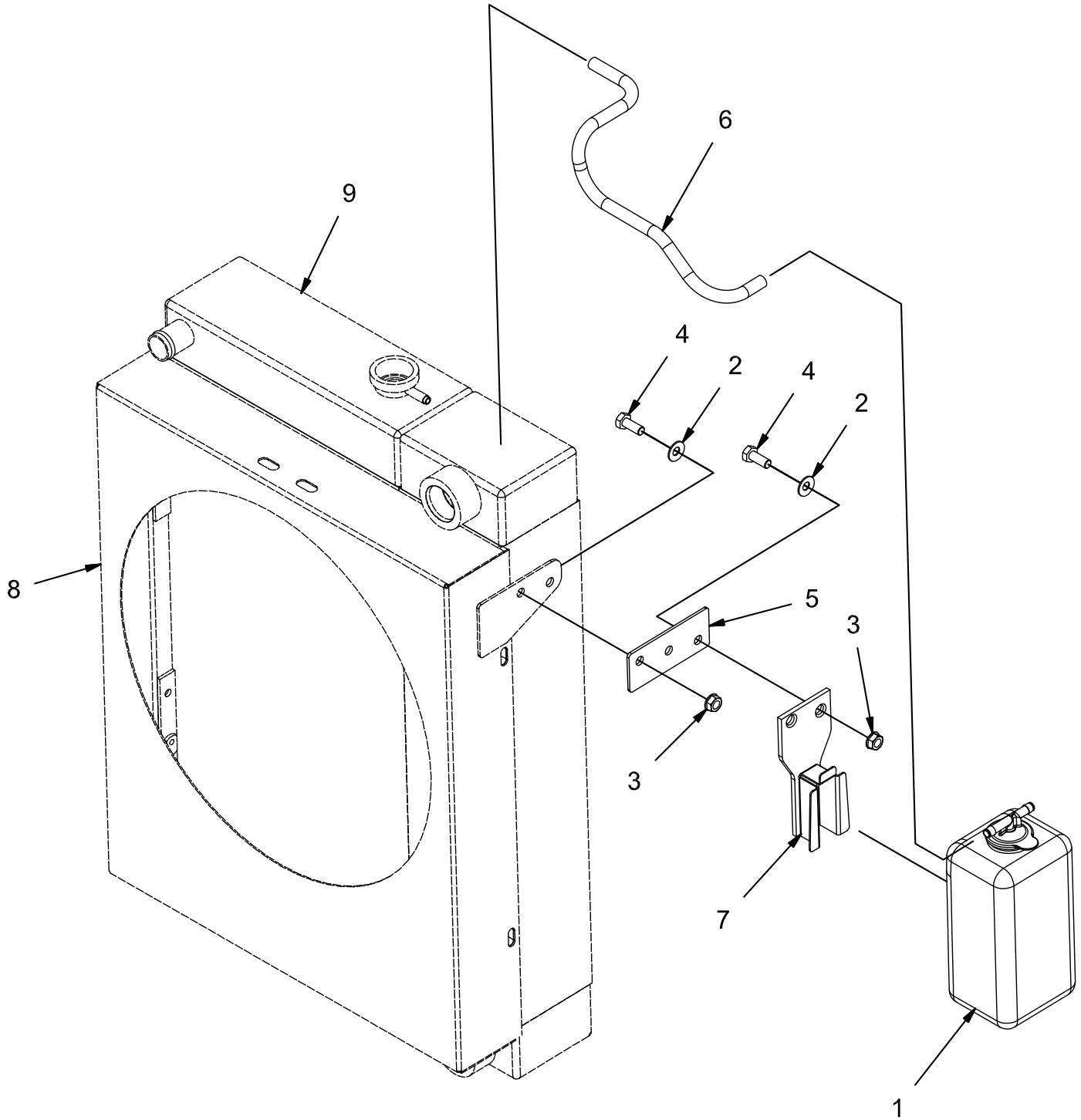

REV A

RADIATOR OVERFLOW BOTTLE GROUP (730133)

Parts List 730133			
ITEM	PART NUMBER	QTY	DESCRIPTION
1	3318752	1	OVERFLOW BOTTLE
2	3400384	3	WASHER, 5/16 BELLEVILLE
3	600934	3	NUT, M8-1.25 FLNG
4	717024	3	BOLT, M8-1.25 X 20 HH
5	731165	1	MOUNT, OVERFLOW BOTTLE
6	PART OF 3318752	1	HOSE, OVERFLOW
7	PART OF 3318752	1	BRACKET, BOTTLE
8	REF.	-	FAN SHROUD, DIESEL
9	REF.	-	RADIATOR

OIL COOLER GROUP (730134)

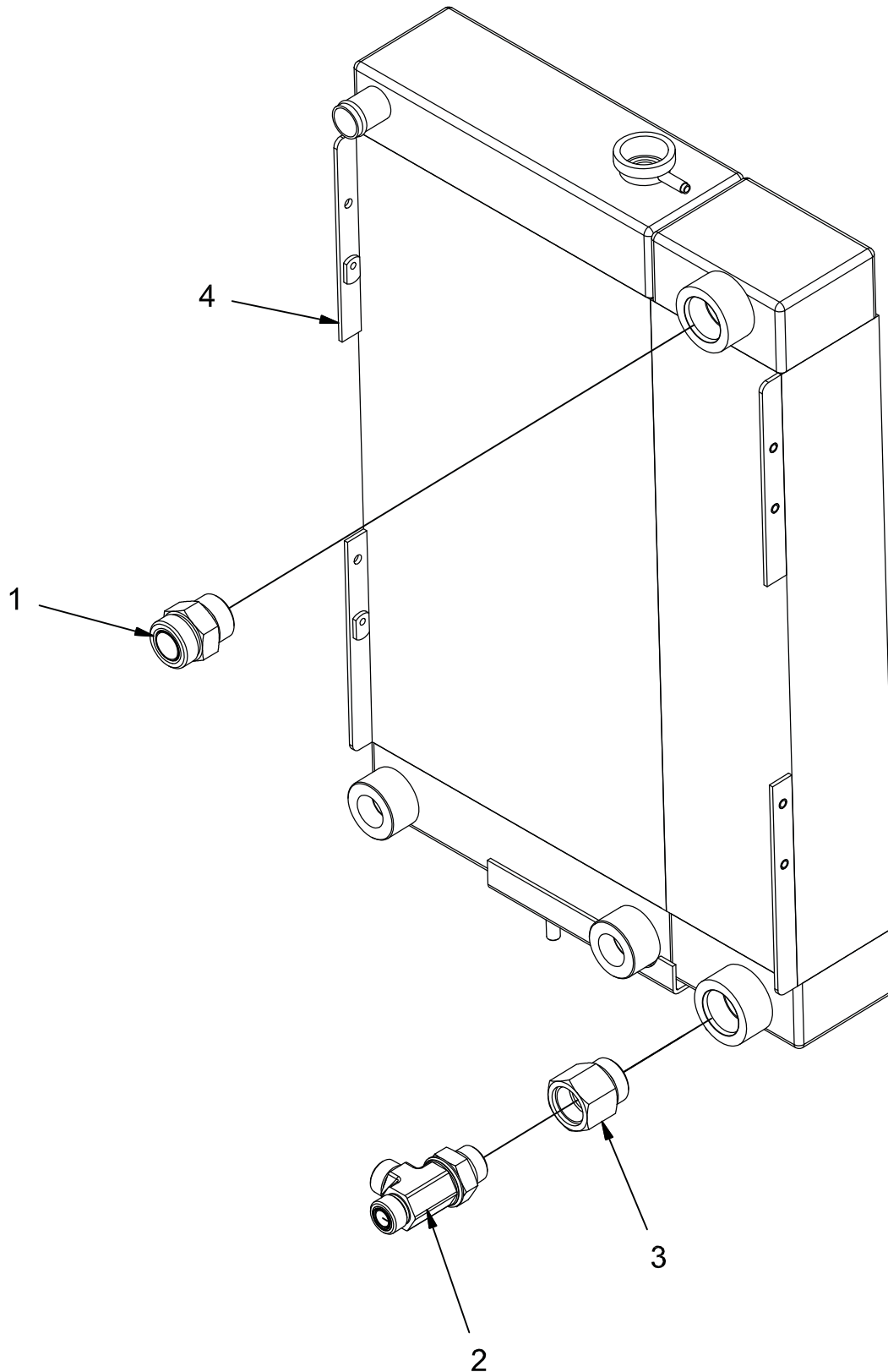

REV *

OIL COOLER GROUP (730134)

Parts List			
ITEM	PART NUMBER	QTY	DESCRIPTION
1	675505	1	FITTING, STR, 16 ORFS - 16 SAE
2	675554	1	FITTING, TEE, 10 ORFS - 12 SAE
3	675558	1	FITTING, REDUCER, 16 O-RING TO 12 O-RING
4	REF	-	RADIATOR - OIL COOLER

EXHAUST GROUP - DIESEL (730154)

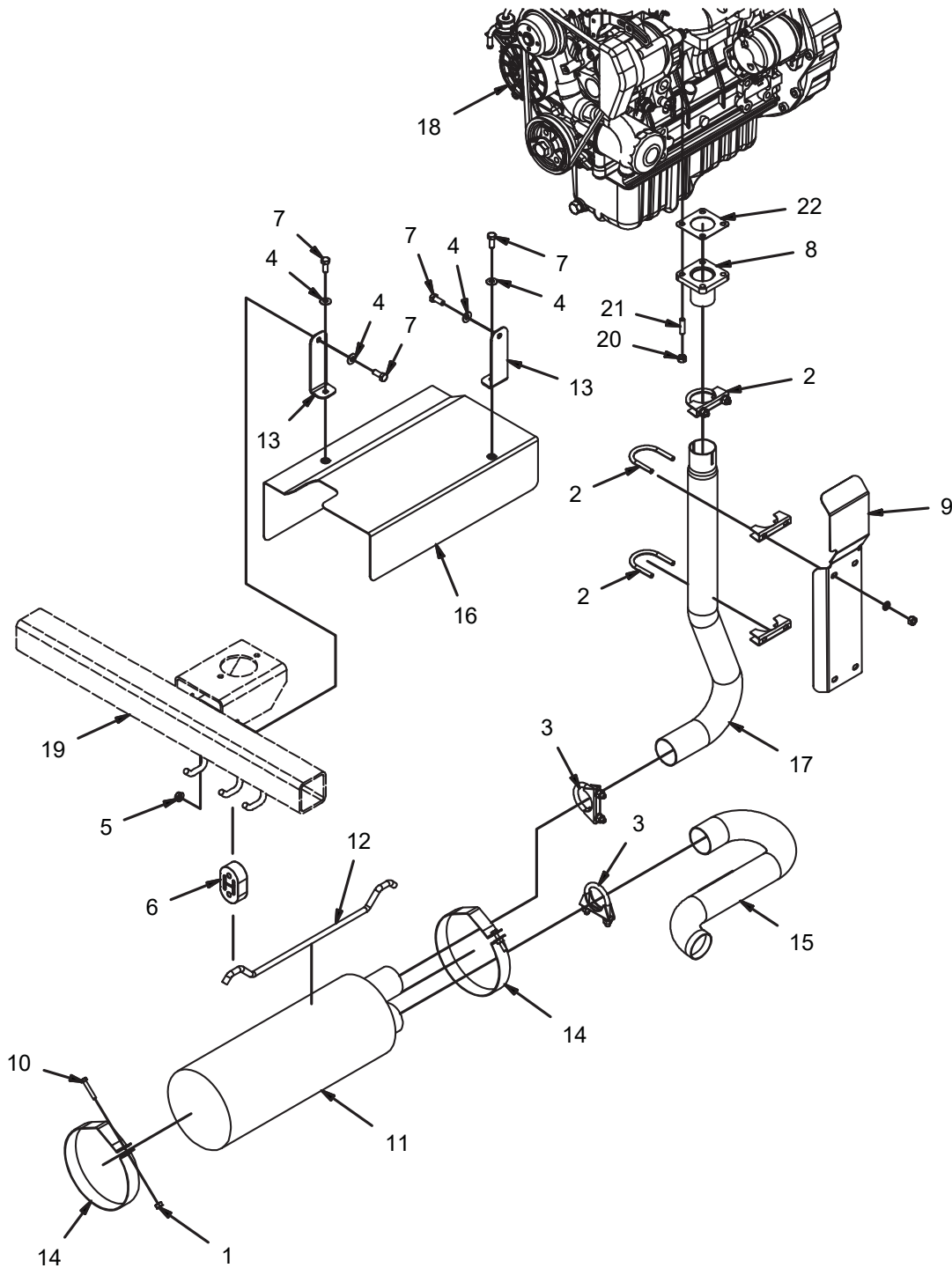

REV D

EXHAUST GROUP - DIESEL (730154)

Parts List - 730154			
ITEM	PART NUMBER	QTY	DESCRIPTION
1	12022042	2	NUT, M6-1.00 HEX
2	3301640	3	CLAMP, 1.75
3	3302917	2	CLAMP, EXHAUST, 2 IN
4	3400384	4	WASHER, 5/16 BELLEVILLE
5	600934	1	NUT, M8-1.25 FLNG
6	620205	1	EXHAUST ISOLATOR
7	717024	4	BOLT, M8-1.25 X 20 HH
8	730409	1	WELDMENT, EXHAUST STUB
9	730419	1	HEAT SHIELD
10	730508	2	BOLT, M6-1.00 X 35 HH FULL THREAD SS
11	731177	1	MUFFLER
12	731178	1	HANGER, MUFFLER
13	731179	2	MOUNT, HEAT SHIELD
14	731180	2	STRAP, MUFFLER
15	731219	1	TAIL PIPE
16	731220-1	1	ASSEMBLY, HEAT SHIELD - DIESEL
17	731222	1	EXHAUST PIPE - DIESEL
18	REF.	-	ENGINE
19	REF.	-	FRAME
20	WITH ENGINE	4	NUT, M8-1.25 SS
21	WITH ENGINE	4	STUD, M8-1.25
22	WITH ENGINE	1	GASKET, EXHAUST

EXHAUST GROUP - GAS / LP (730178)

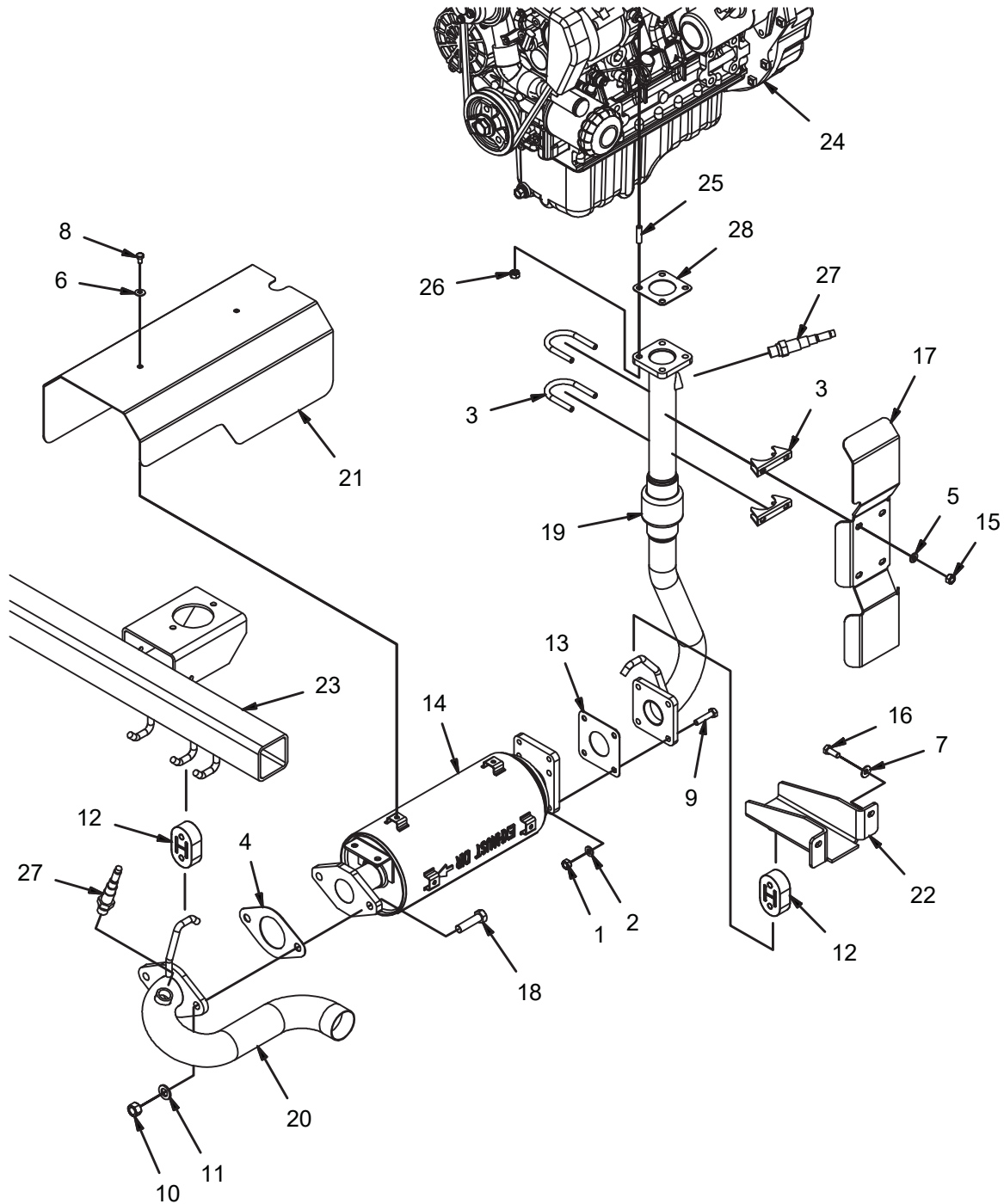

REV *

EXHAUST GROUP - GAS / LP (730178)

Parts List 730178			
ITEM	PART NUMBER	QTY	DESCRIPTION
1	12022059	4	NUT, M8-1.25
2	12310041	4	WASHER, M8
3	3301641	2	CLAMP, EXHAUST
4	3345028	1	GASKET - CAT 3605
5	3400102	4	LOCK WASHER, 5/16 HS MED
6	3400383	2	WASHER, 1/4 BELLEVILLE
7	3400384	2	WASHER, 5/16 BELLEVILLE
8	361255	2	BOLT, M6-1.00 X 10 HH ZP
9	600918	4	BOLT, M8-125 X 35 HH
10	600949	2	NUT, M12-1.75
11	600950	2	WASHER, M12
12	620205	2	EXHAUST ISOLATOR
13	690190	1	GASKET, CATALYST, 4-BOLT
14	690191	1	CATALYTIC CONVERTER, LPG - GAS
15	711319	4	NUT, HEX 5/16-18
16	717024	2	BOLT, M8-1.25 X 20 HH
17	730665	1	HEAT SHIELD
18	730667	2	BOLT, M12-1.75 X 45 HH
19	731327	1	WELDMENT, EXHAUST PIPE, GAS - LPG
20	731328	1	WELDMENT, EXHAUST PIPE
21	731432	1	HEAT SHIELD
22	731465	1	WELDMENT, EXHAUST HANGER
23	REF.	-	FRAME, ENG TUBE
24	REF.	-	ENGINE
25	WITH ENGINE	4	STUD, M8-1.25
26	WITH ENGINE	4	NUT, M8-1.25 SS
27	WITH ENGINE	2	O2 SENSOR
28	WITH ENGINE	1	GASKET, EXHAUST

FUEL TANK MOUNT GROUP - DIESEL (730140)

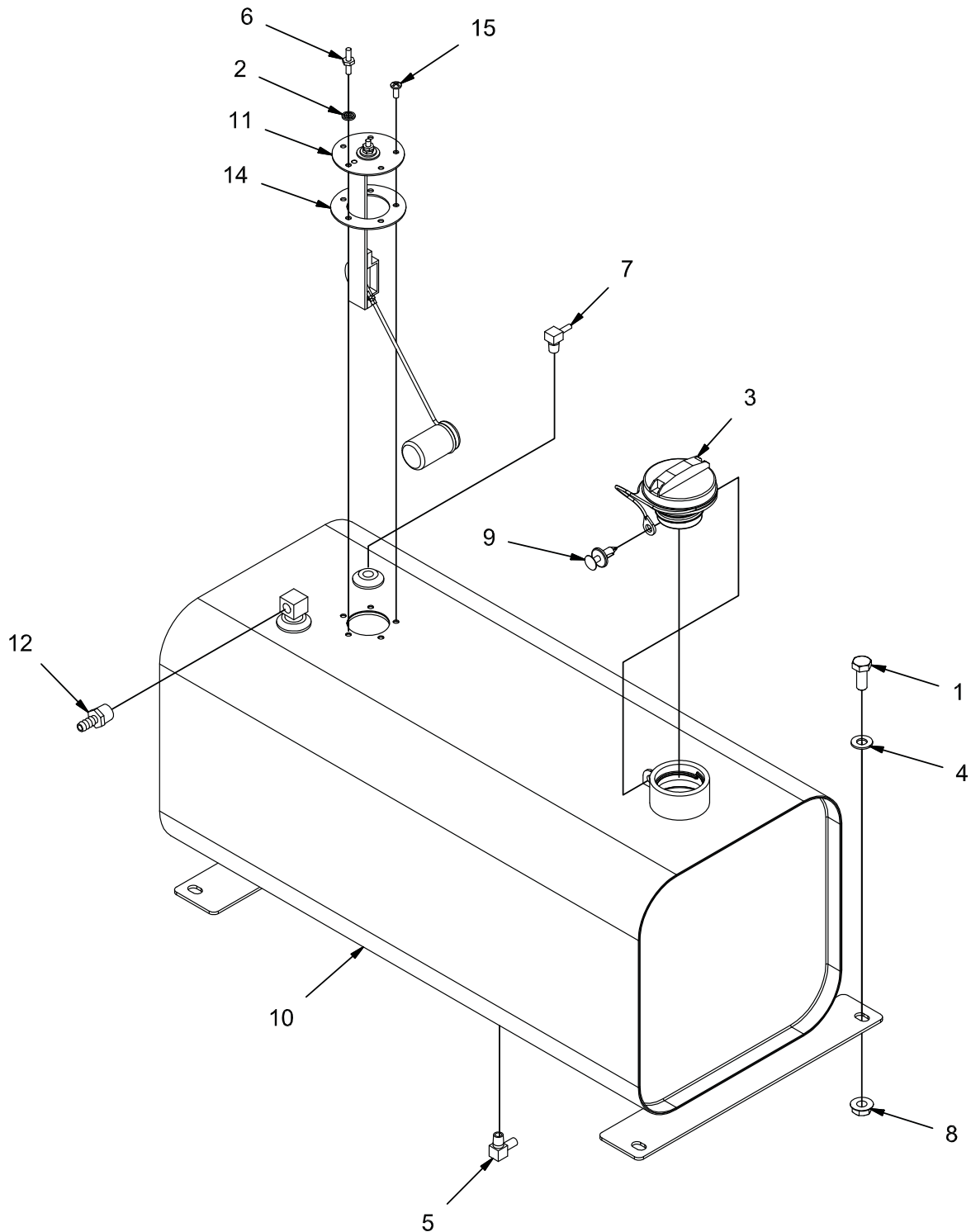

REV B

FUEL TANK MOUNT GROUP - DIESEL (730140)

Parts List 730140			
ITEM	PART NUMBER	QTY	DESCRIPTION
1	11038346	4	BOLT, M10-1.50 X 25 HH
2	3337019	1	SEAL, #10
3	3343413	1	CAP, FUEL TANK
4	3400385	4	WASHER, 3/8, BELLEVILLE
5	3401445	1	FITTING, 90, 1/4 NPT X 5/16 BARB
6	3401579	1	SCREW, HEX, STANDOFF, 2X #10-32 X .50
7	3402022	1	FITTING, 90, 1/4 NPT X .184 BARB
8	600936	4	NUT, M10-1.50 FLNG
9	600965	1	FASTENER, PRESS-IN
10	730313	1	TANK, FUEL
11	730322	1	SENDING UNIT, FUEL LEVEL
12	731387	1	FITTING, 3/8 NPT TO 5/16 HOSE BARB, BRASS
13	748990-1	1	HARNESS, FUEL PUMP
14	PART OF 730322	1	GASKET
15	PART OF 730322	4	SCREW #10-32 X .50

FUEL TANK MOUNT GROUP - GAS (730139)

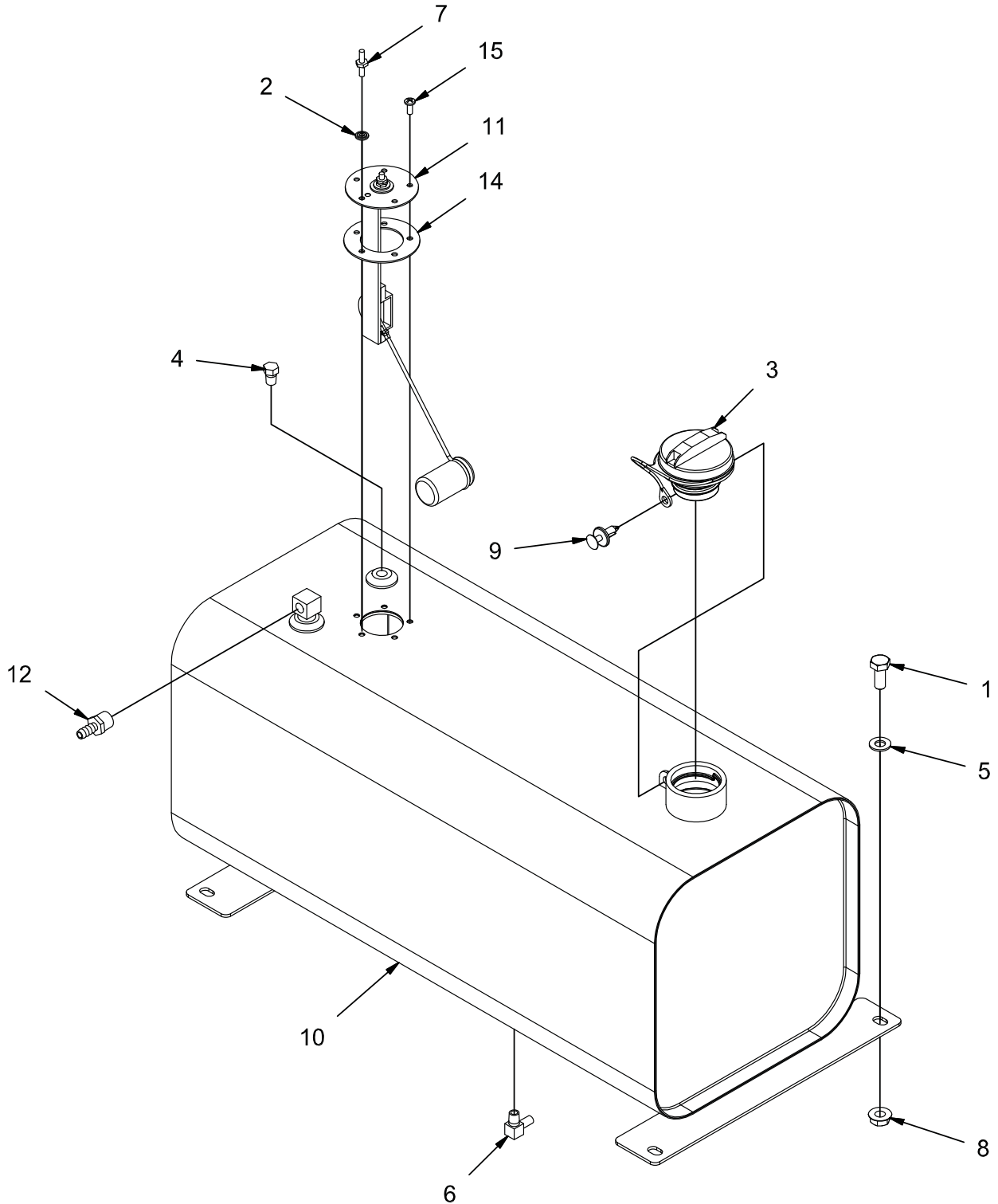

REV C

FUEL TANK MOUNT GROUP - GAS (730139)

Parts List 730139			
ITEM	PART NUMBER	QTY	DESCRIPTION
1	11038346	4	BOLT, M10-1.50 X 25 HH
2	3337019	1	SEAL, #10
3	3343413	1	CAP, FUEL TANK
4	3400256	1	PLUG, 1/4 NPT
5	3400385	4	WASHER, 3/8, BELLEVILLE
6	3401445	1	FITTING, 90, 1/4 NPT X 5/16 BARB
7	3401579	1	SCREW, HEX, STANDOFF, 2X #10-32 X .50
8	600936	4	NUT, M10-1.50 FLNG
9	600965	1	FASTENER, PRESS-IN
10	730313	1	TANK, FUEL
11	730322	1	SENDING UNIT, FUEL LEVEL
12	731387	1	FITTING, 3/8 NPT - 5/16 HOSE BARB
13	748990-1	1	HARNESS, FUEL PUMP
14	PART OF 730322	1	GASKET
15	PART OF 730322	4	SCREW #10-32 X .50

LPG TANK MOUNT GROUP (730138)

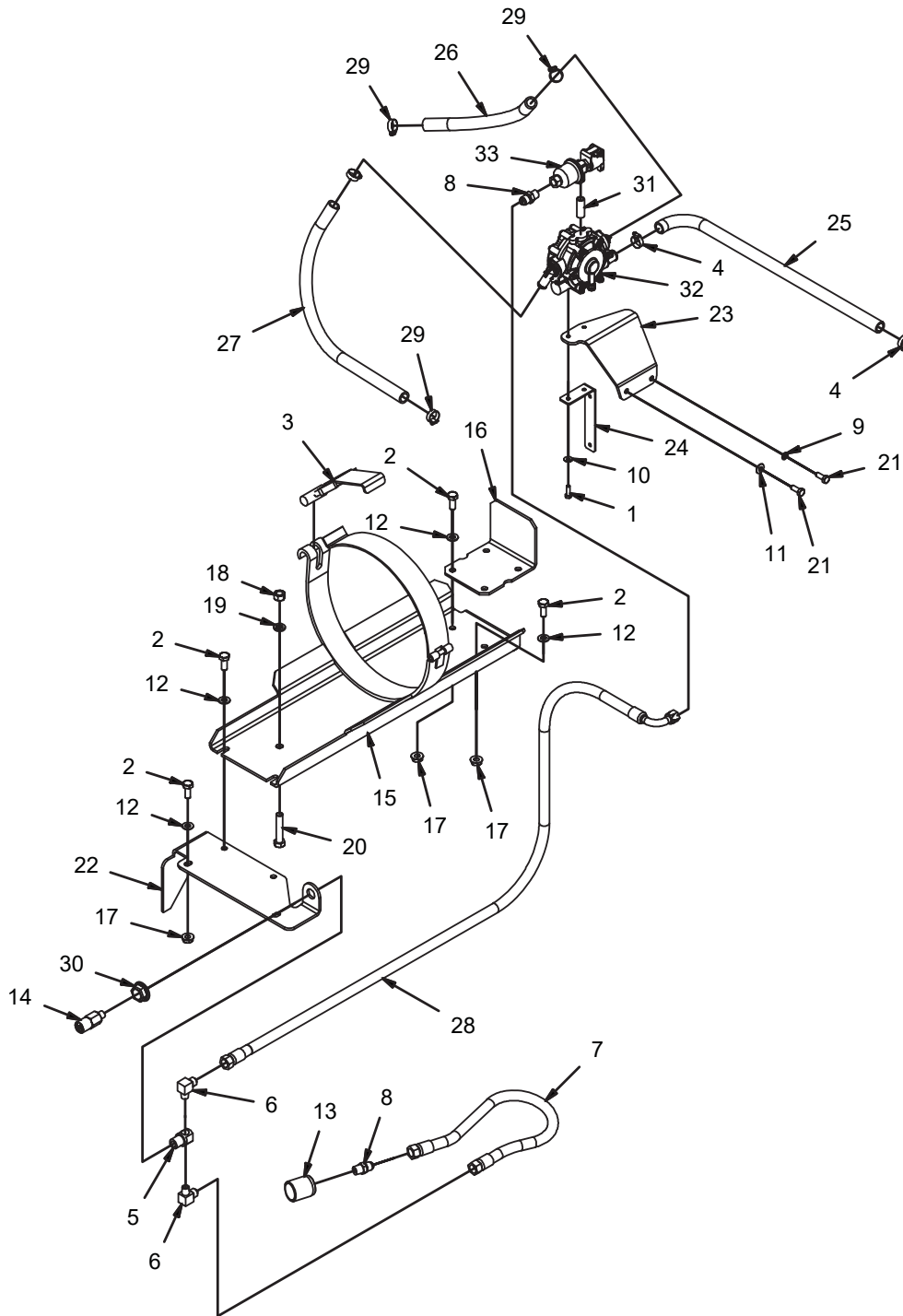

REV F

LPG TANK MOUNT GROUP (730138)

Parts List - 730138			
ITEM	PART NUMBER	QTY	DESCRIPTION
1	11038098	2	BOLT, M6-100 X 20 HH
2	11038346	8	BOLT, M10-1.50 X 25 HH
3	220131	1	BUCKLE
4	3300535	2	CLAMP, HOSE, .50
5	3316511	1	BODY, VALVE MOUNT
6	3334037	2	FITTING, 90, BRASS, LPG
7	3335375	1	HOSE, LPG, TO TANK
8	3342097	2	FTG SAE 5/8-18 45 DEGREE FLARE
9	3400273	1	WASHER, STAR, .31, INT. ZP
10	3400383	2	WASHER, 1/4 BELLEVILLE
11	3400384	1	WASHER, 5/16 BELLEVILLE
12	3400385	8	WASHER, 3/8, BELLEVILLE
13	3400860	1	FTG-LP TANK CONNECT
14	3400862	1	LPG RELIEF VALVE
15	600459-1	1	WELDMENT, LPG MNT
16	600461-1	1	ANGLE, LPG STOP
17	600936	8	NUT, M10-1.50 FLNG
18	600949	1	NUT, M12-1.75
19	600961	1	LOCK WASHER, M12
20	620036	1	BOLT, M12-1.75 X 60 HH FULL THREAD
21	717024	2	BOLT, M8-1.25 X 20 HH
22	730533	1	MOUNT, LPG VALVE
23	730890	1	BRACKET, VAPORIZER
24	731164	1	MOUNT, FUSE BOX
25	731167	1	HOSE, VAPORIZER TO CARB
26	731173	1	HOSE, COOLANT, 5/8" ID X 15.0" LG
27	731174	1	HOSE, COOLANT, 5/8" ID X 43.0" LG
28	731186	1	HOSE, LPG TANK TO VAPORIZER
29	829129	4	CLAMP, HOSE
30	PART OF 3316511	1	NUT, VALVE MOUNT
31	PART OF ENGINE	1	FITTING, NIPPLE
32	PART OF ENGINE	1	VAPORIZER (13098-62401)
33	PART OF ENGINE	1	SOLENOID AND LOCK OFF (EG523-46951)

FUEL LINE GROUP - DIESEL (730153)

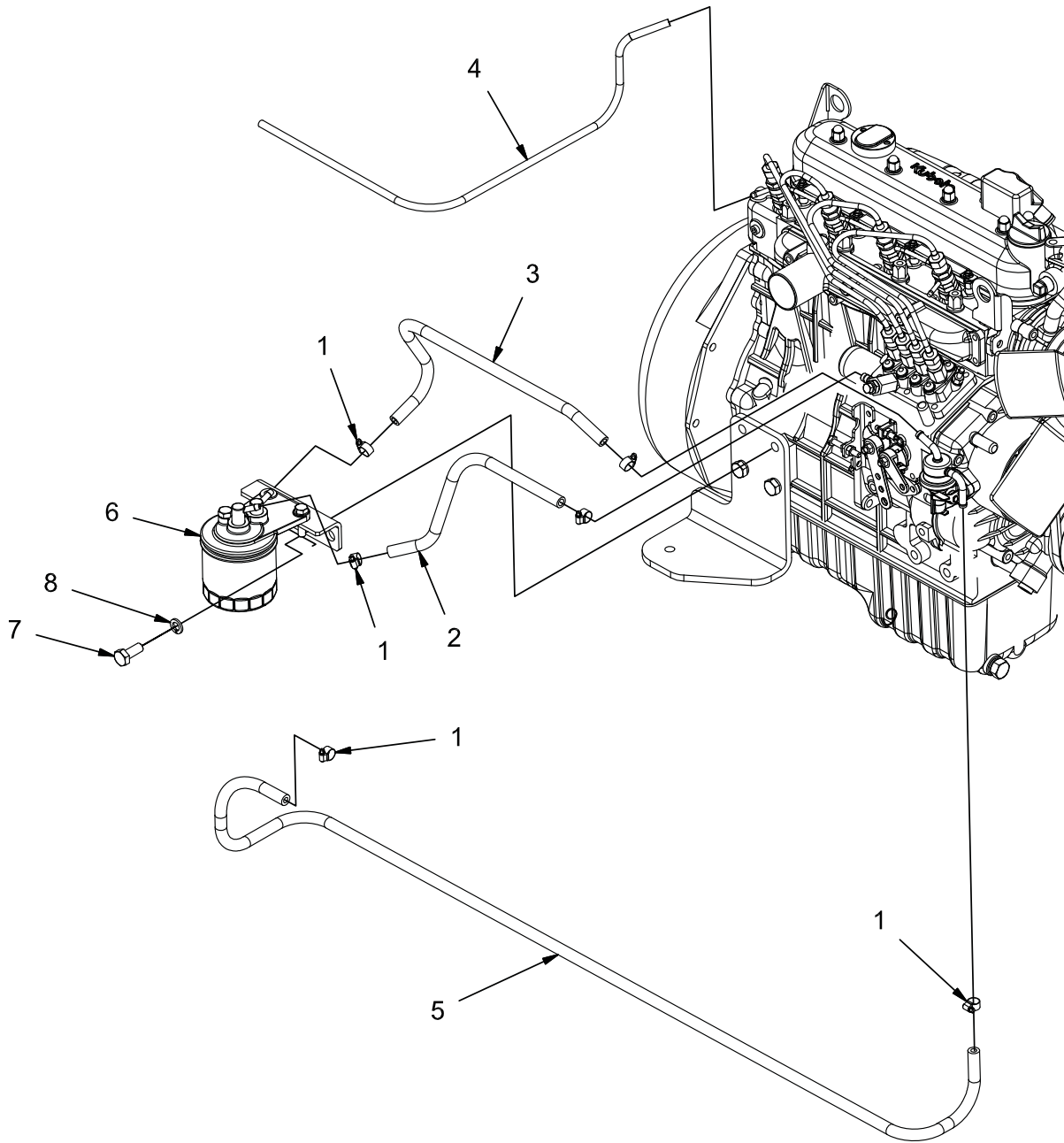

REV *

FUEL LINE GROUP - DIESEL (730153)

Parts List - 730153			
ITEM	PART NUMBER	QTY	DESCRIPTION
1	3302338	6	CLAMP, HOSE, .50
2	620001	1	HOSE,FUEL, 5/16 ID 12.00 LG, SAE30R7
3	620061	1	HOSE,FUEL, 5/16 ID 18.00 LG, SAE30R7
4	NO DWG	1	HOSE, FUEL, 1/8 ID SAE30R7
5	NO DWG	1	HOSE, FUEL, 5/16 ID SAE30R7
6	PART OF ENGINE	-	FUEL FILTER ASSEMBLY
7	REF.	-	BOLT, M10-1.50 X 25 HH
8	REF.	-	LOCK WASHER, M10
9	REF.	-	ENGINE, DIESEL

FUEL COMPONENT GROUP - GAS (730141)

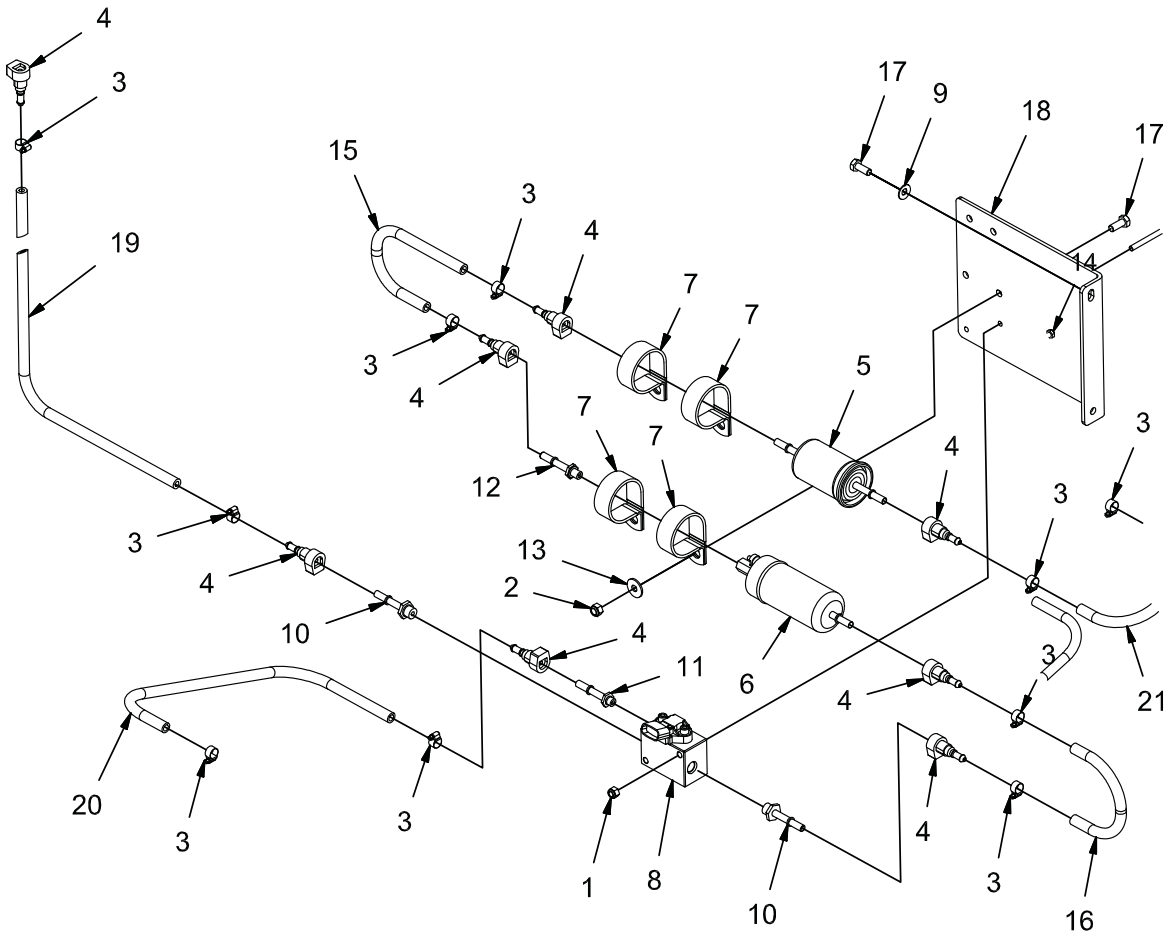

REV *

FUEL COMPONENT GROUP - GAS (730141)

Parts List 730141			
ITEM	PART NUMBER	QTY	DESCRIPTION
1	12040044	2	NUT, M6-1.00 ESN
2	12040051	4	NUT, M8-1.25 ESN
3	3302338	10	CLAMP, HOSE, .50
4	3342207	8	FITTING, ADAPTER, FUEL
5	3342209	1	FILTER, FUEL
6	3343536	1	PUMP, FUEL
7	3343539	4	CLAMP, 2"
8	3343617	1	MANIFOLD, FUEL PRESS/TEMP
9	3400384	2	WASHER, 5/16 BELLEVILLE
10	3401088	2	FTG-ADAPTER, FUEL 1/2-20 W/O-RING
11	3401089	1	FTG-ADAPTER, FUEL 3/8-24 W/O-RING
12	3401090	1	FITTING & GASKET FOR FUEL PUMP
13	600940	4	WASHER, M8 FENDER
14	600953	2	BOLT, M6-1.00 X 50 HH
15	620001	1	HOSE,FUEL, 5/16 ID X 12.00 LG, SAE30R7
16	620002	1	HOSE,FUEL, 5/16 ID X 10.00 LG, SAE30R7
17	717024	6	BOLT, M8-1.25 X 20 HH
18	730311	1	MOUNT, FUEL FILTER
19	TBD	1	HOSE,FUEL, 5/16 ID SAE30R7 (TO ENGINE)
20	TBD	1	HOSE,FUEL, 5/16 ID SAE30R7 (FUEL RETURN)
21	TBD	1	HOSE,FUEL, 5/16 ID SAE30R7 (FROM TANK)

THROTTLE SOLENOID GROUP - DIESEL (730151)

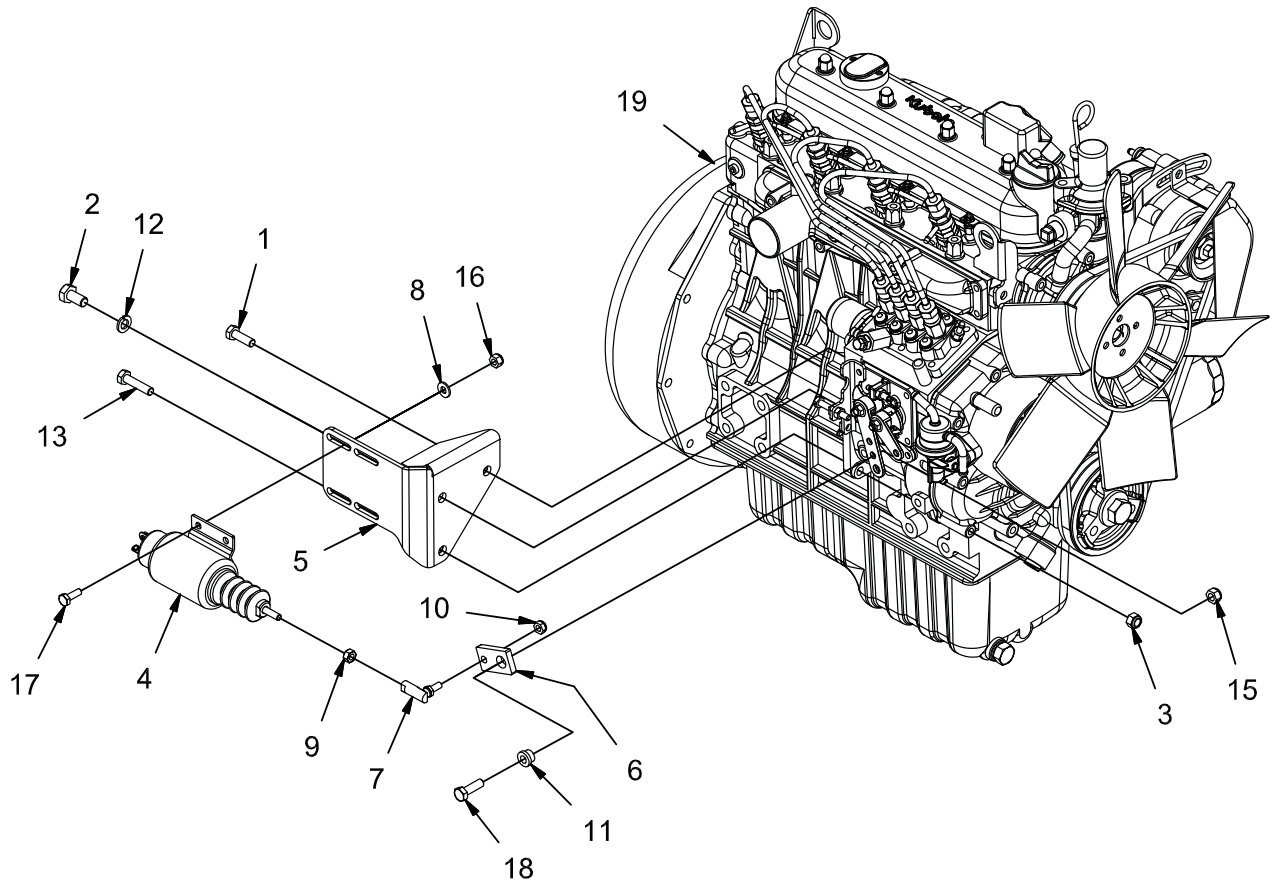

REV A

THROTTLE SOLENOID GROUP - DIESEL (730151)

Parts List - 730151			
ITEM	PART NUMBER	QTY	DESCRIPTION
1	11038247	1	BLT-HH M8-1.25 X 25 STL ZINC
2	11038353	1	BOLT, M10-1.50 X 20 HH
3	12040051	1	NUT, M8-1.25 ESN
4	3335303	1	SOLENOID, THROTTLE
5	3335358	1	BRACKET, THROTTLE SOLENOID
6	3335364	1	PLT, KBA V1505 DSL SOLENOID THROTTLE
7	3342225	1	BALL JOINT, 1/4-28 STD LG
8	3400089	4	WASHER, 1/4 .625 X .281 X .063
9	3400180	1	NUT, 1/4-28
10	3400373	1	NUT, LOW HEIGHT 1/4-28 ESN
11	3401071	1	BUSHING, FLNG, .312 ID X .50 OD X .375
12	3401458	1	LOCK WASHER, M10
13	600918	1	BOLT, M8-125 X 35 HH
14	600959	2	LOCK WASHER, M8
15	711374	1	NUT, FIBER INSERT 5/16-18
16	711373	4	NUT, FIBER INSERT 1/4-20
17	713002	4	SCREW, 1/4-20 X .750 HHC
18	713027	1	SCREW, 5/16-18 X 1.000 HHM
19	REF.	-	ENGINE, DIESEL

BATTERY GROUP (730142)

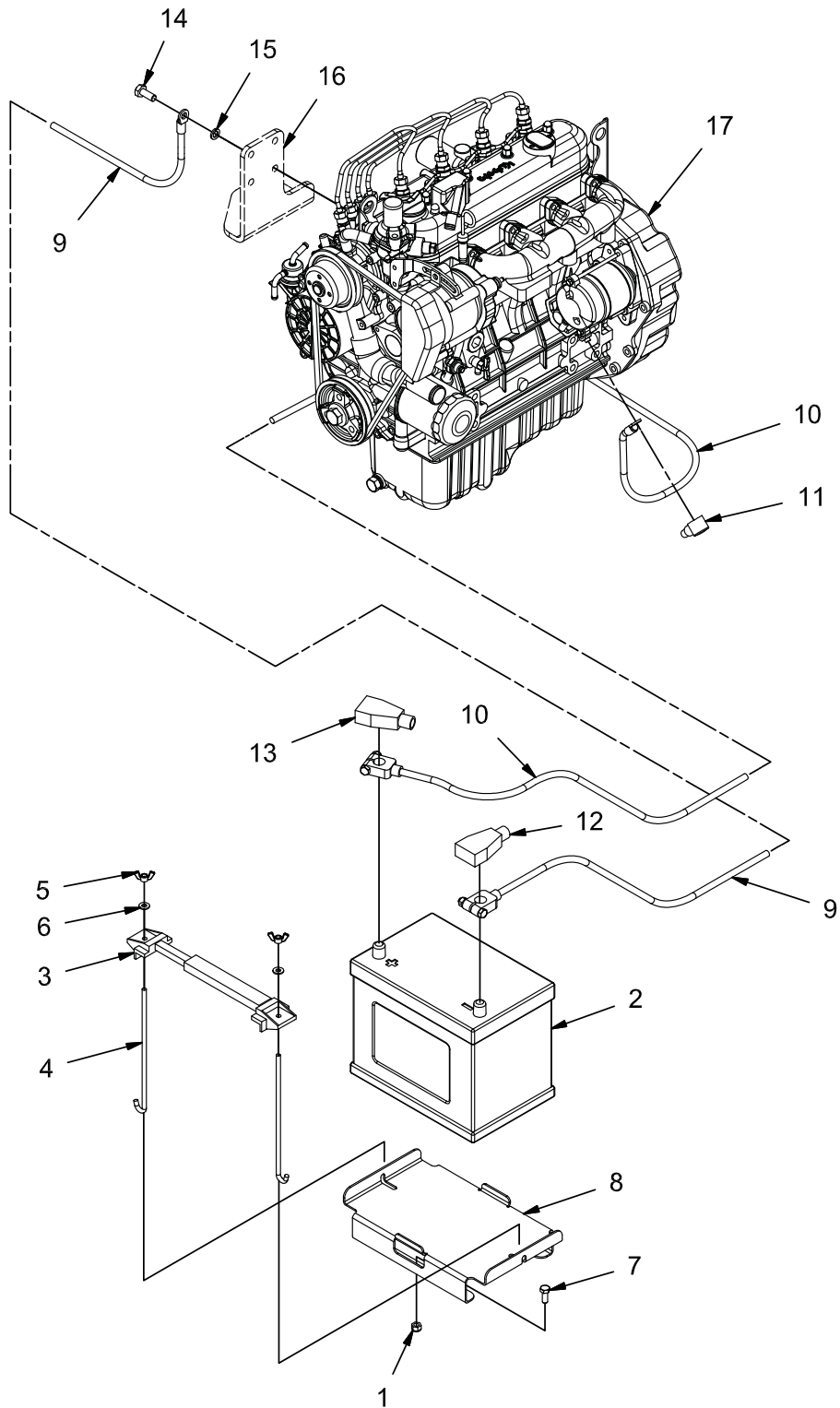

REV A

BATTERY GROUP (730142)

Parts List 730142			
ITEM	PART NUMBER	QTY	DESCRIPTION
1	12040051	2	NUT, M8-1.25 ESN
2	3300440	1	BATTERY, 12V
3	3301076	1	HOLD DOWN, BATTERY
4	3301079	2	ROD, BATTERY TIE DOWN
5	3400085	2	WING NUT, 1/4-20 ZP
6	3400089	2	WASHER, 1/4 .625 X .281 X .063
7	717024	2	BOLT, M8-1.25 X 20 HH
8	730390	1	TRAY, BATTERY
9	748993	1	CABLE, BATTERY, NEG
10	748994	1	CABLE, BATTERY, POS
11	742740	1	BOOT, TERM, RED
12	PART OF CABLE	1	BOOT, BATTERY, BLACK
13	PART OF CABLE	1	BOOT, BATTERY, RED
14	REF.	-	BOLT, M10-1.25 X 25 HH ZP
15	REF.	-	LOCK WASHER, M10
16	REF.	-	ENGINE MOUNT
17	REF.	-	ENGINE

FRONT COVER GROUP (730143)

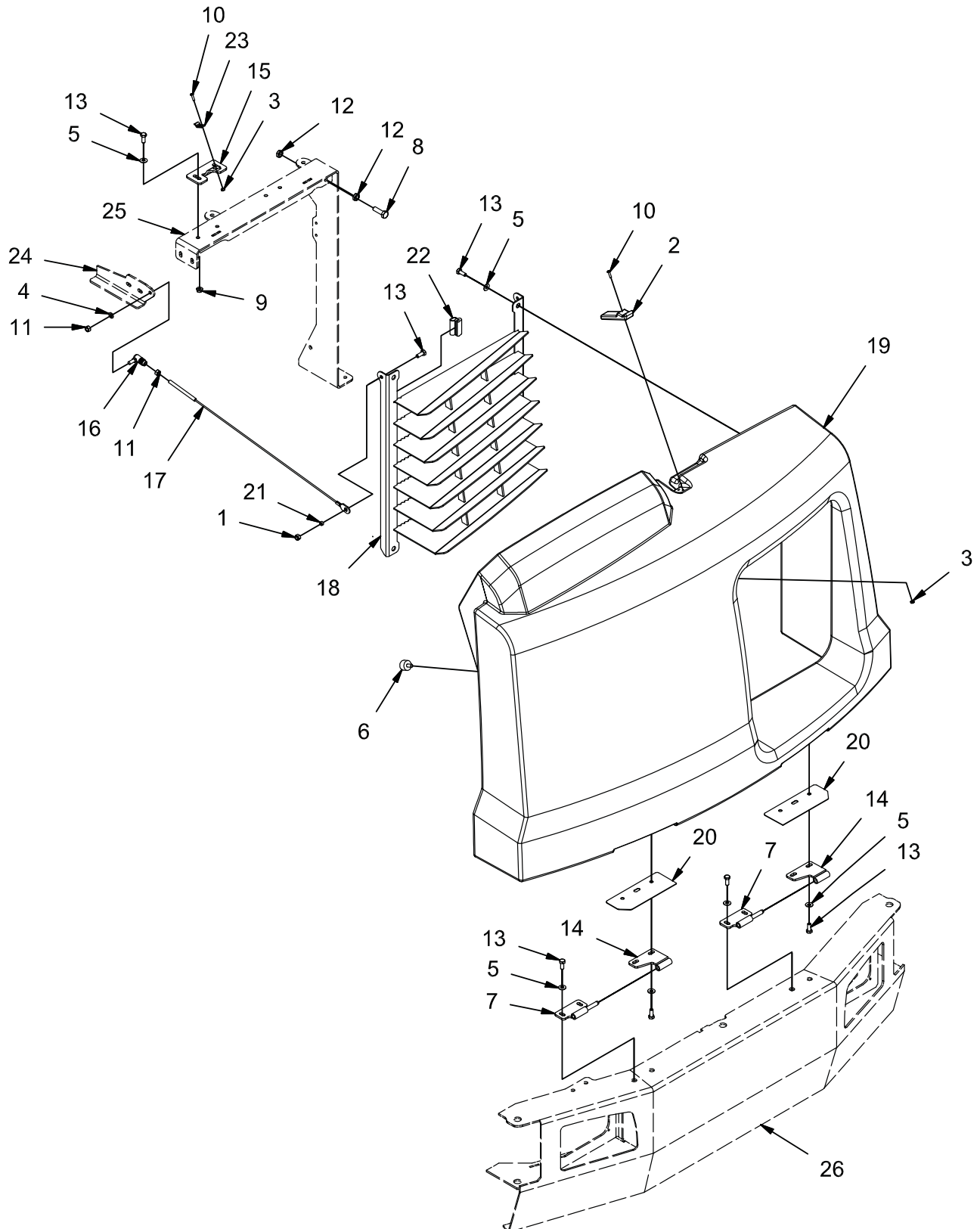

REV C

FRONT COVER GROUP (730143)

Parts List 730143			
ITEM	PART NUMBER	QTY	DESCRIPTION
1	12040051	1	NUT, M8-1.25 ESN
2	3307719	1	DRAW LATCH
3	3400082	4	NUT, FIBER INSERT #8-32
4	3400102	1	LOCK WASHER, 5/16 HS MED
5	3400384	14	WASHER, 5/16 BELLEVILLE
6	600220	1	BUMPER, 1.00 X .625 T
7	600383	2	WELDMENT, HINGE, MALE, LG
8	600924	1	BOLT, M10-1.50 X 35 HH FULL THRD
9	600934	2	NUT, M8-1.25 FLNG
10	710230	4	SCREW, #8-32 X .62 PAN HD
11	711322	2	NUT, HEX 5/16-24 ZP
12	717014	2	NUT, M10-1.50 JAM
13	717024	15	BOLT, M8-1.25 X 20 HH
14	730407	2	WELDMENT, HINGE, FEM
15	730429	1	MOUNT, STRIKER
16	730430	1	BALL JOINT, .312, QUICK RELEASE
17	730431	1	CABLE ASSEMBLY
18	730434	1	WELDMENT, GRILL
19	730446	1	FRONT COVER
20	730447	2	COVER, HINGE
21	730448	1	SPACER, .328 B .375 OD .188 T
22	731265	1	EDGING, GRILL
23	PART OF 3307719	1	KEEPER
24	REF	-	CONSOLE MTG ANGLE
25	REF	-	COVER FRAME
26	REF	-	FRAME

TOP COVER GROUP (730144)

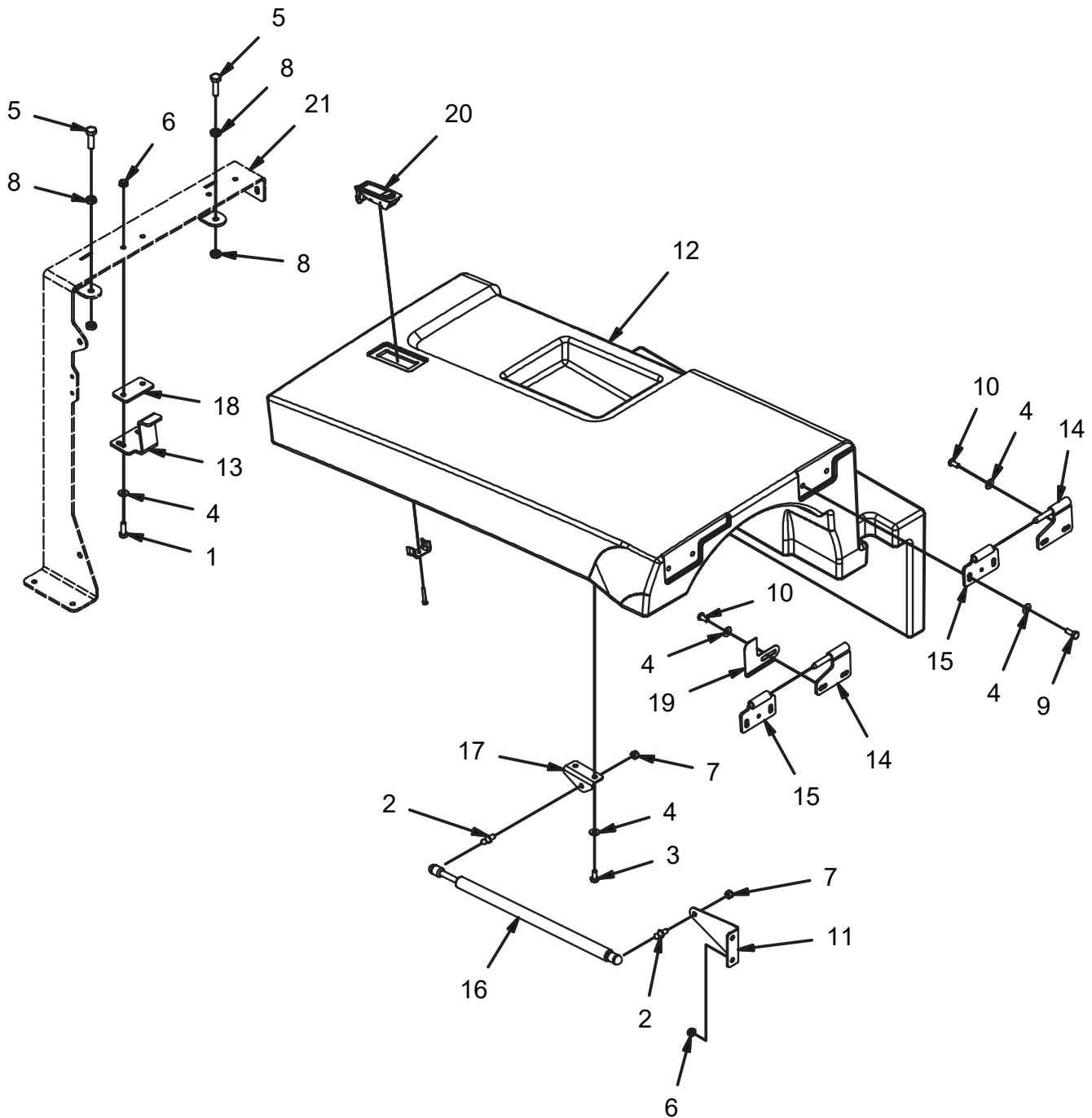

REV D

TOP COVER GROUP (730144)

Parts List 730144			
ITEM	PART NUMBER	QTY	DESCRIPTION
1	11038247	2	BLT-HH M8-1.25 X 25 STL ZINC
2	3300376	2	STUD, 10MM BALL
3	3400291	2	BOLT, M8-1.25 X 16 HH
4	3400384	12	WASHER, 5/16 BELLEVILLE
5	600924	2	BOLT, M10-1.50 X 35 HH FULL THRD
6	600934	4	NUT, M8-1.25 FLNG
7	711374	2	NUT, FIBER INSERT 5/16-18
8	717014	4	NUT, M10-1.50 JAM
9	717024	3	BOLT, M8-1.25 X 20 HH
10	730399	4	SCREW, M8-1.25 X 16 BUTTON HD CAP CZP
11	730433	1	MOUNT, GAS STRUT
12	730450	1	TOP COVER
13	730452	1	STRIKER, TOP COVER
14	730454	2	WELDMENT, HINGE, MALE
15	730456	2	WELDMENT, HINGE, FEM
16	730457	1	GAS STRUT, 30.9 EXT X 13.8 STK
17	730459	1	ANGLE, GAS STRUT MNT
18	730461	1	BAR, SPACER
19	731132	1	RETAINER, COVER
20	731433	1	LATCH
21	REF	-	COVER FRAME

SIDE DOOR GROUP (730145)

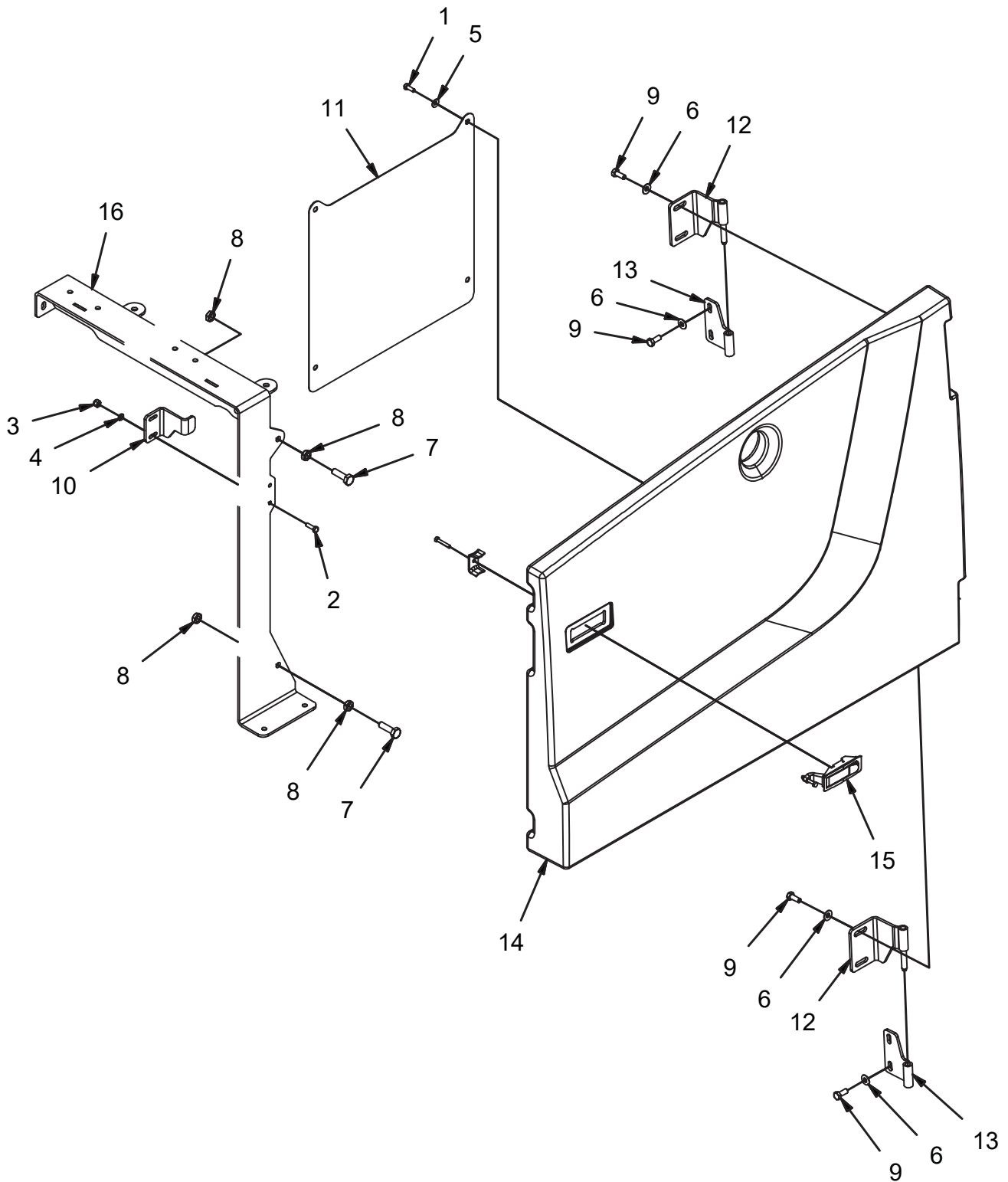

REV B

SIDE DOOR GROUP (730145)

Parts List 730145			
ITEM	PART NUMBER	QTY	DESCRIPTION
1	11038072	4	BOLT, M6-1.00 X 16 HH
2	11038098	2	BOLT, M6-100 X 20 HH
3	12040044	2	NUT, M6-1.00 ESN
4	12310033	2	WASHER, M6
5	3400383	4	WASHER, 1/4 BELLEVILLE
6	3400384	8	WASHER, 5/16 BELLEVILLE
7	600924	2	BOLT, M10-1.50 X 35 HH FULL THRD
8	717014	4	NUT, M10-1.50 JAM
9	717024	8	BOLT, M8-1.25 X 20 HH
10	730403	1	STRIKER, DOOR
11	730404	1	SHIELD, HEAT
12	730405	2	WELDMENT, HINGE, MALE
13	730407	2	WELDMENT, HINGE, FEM
14	730428	1	DOOR, LEFT SIDE
15	731433	1	LATCH
16	REF.	-	COVER FRAME

SEAT DOOR GROUP (730146)

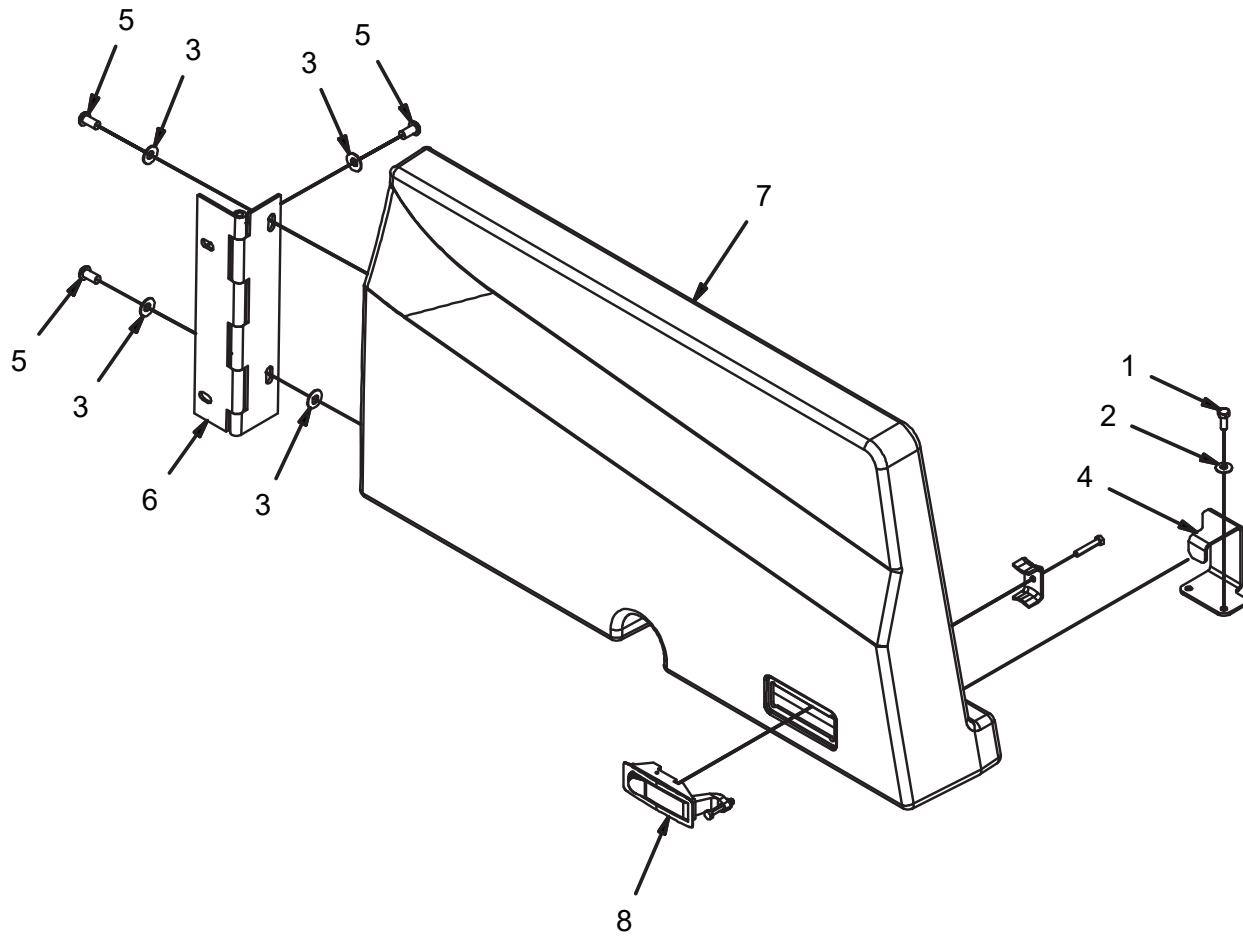

REV B

SEAT DOOR GROUP (730146)

Parts List 730146			
ITEM	PART NUMBER	QTY	DESCRIPTION
1	11038072	2	BOLT, M6-1.00 X 16 HH
2	3400383	2	WASHER, 1/4 BELLEVILLE
3	3400384	5	WASHER, 5/16 BELLEVILLE
4	730398	1	STRIKER, SEAT DOOR
5	730399	4	SCREW, M8-1.25 X 16 BUTTON HD CAP CZP
6	730400	1	HINGE, CONT, 4"
7	730449	1	DOOR, SEAT
8	731433	1	LATCH

SEAT MOUNT GROUP (730147)

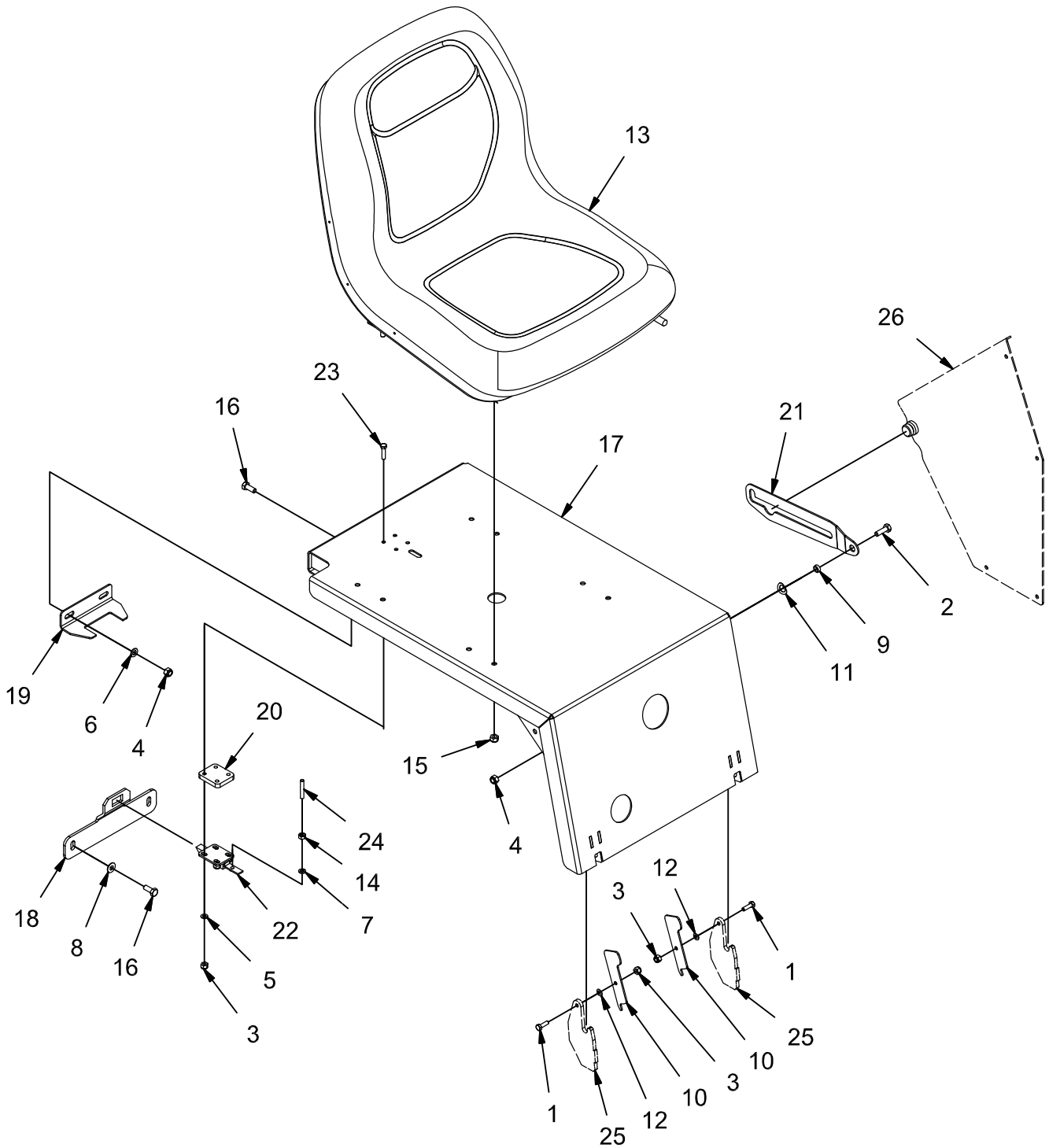

REV C

SEAT MOUNT GROUP (730147)

Parts List 730147			
ITEM	PART NUMBER	QTY	DESCRIPTION
1	11038098	2	BOLT, M6-100 X 20 HH
2	11038247	1	BLT-HH M8-1.25 X 25 STL ZINC
3	12040044	6	NUT, M6-1.00 ESN
4	12040051	3	NUT, M8-1.25 ESN
5	12310033	4	WASHER, M6
6	12310041	2	WASHER, M8
7	3400103	1	LOCK WASHER, 1/4 HS MED
8	3400384	2	WASHER, 5/16 BELLEVILLE
9	600138	1	SPACER, .328 B .500 OD .188 T
10	600194	2	LATCH, COVER
11	600948	1	WASHER, .50 CURVED SPRING
12	600963	2	WASHER, M6, CURVED SPRING
13	620219	1	SEAT
14	711316	1	NUT, HEX 1/4-20 ZINC PL
15	711374	4	NUT, FIBER INSERT 5/16-18
16	717024	4	BOLT, M8-1.25 X 20 HH
17	730320	1	WELDMENT, SEAT MNT
18	730482	1	BRACKET, SEAT STRIKER
19	730484	1	PLATE, SEAT LOCK
20	730486	1	PLT, SPACER
21	730487	1	SUPPORT, SEAT MNT
22	730488	1	SLIDE LATCH
23	731006	4	BOLT, M6-1.00 X 25 HH ZP
24	731163	1	ROD, LATCH
25	REF	-	CONSOLE
26	REF	-	COVER PLATE

HYDRAULIC HOSE GROUP (730148)

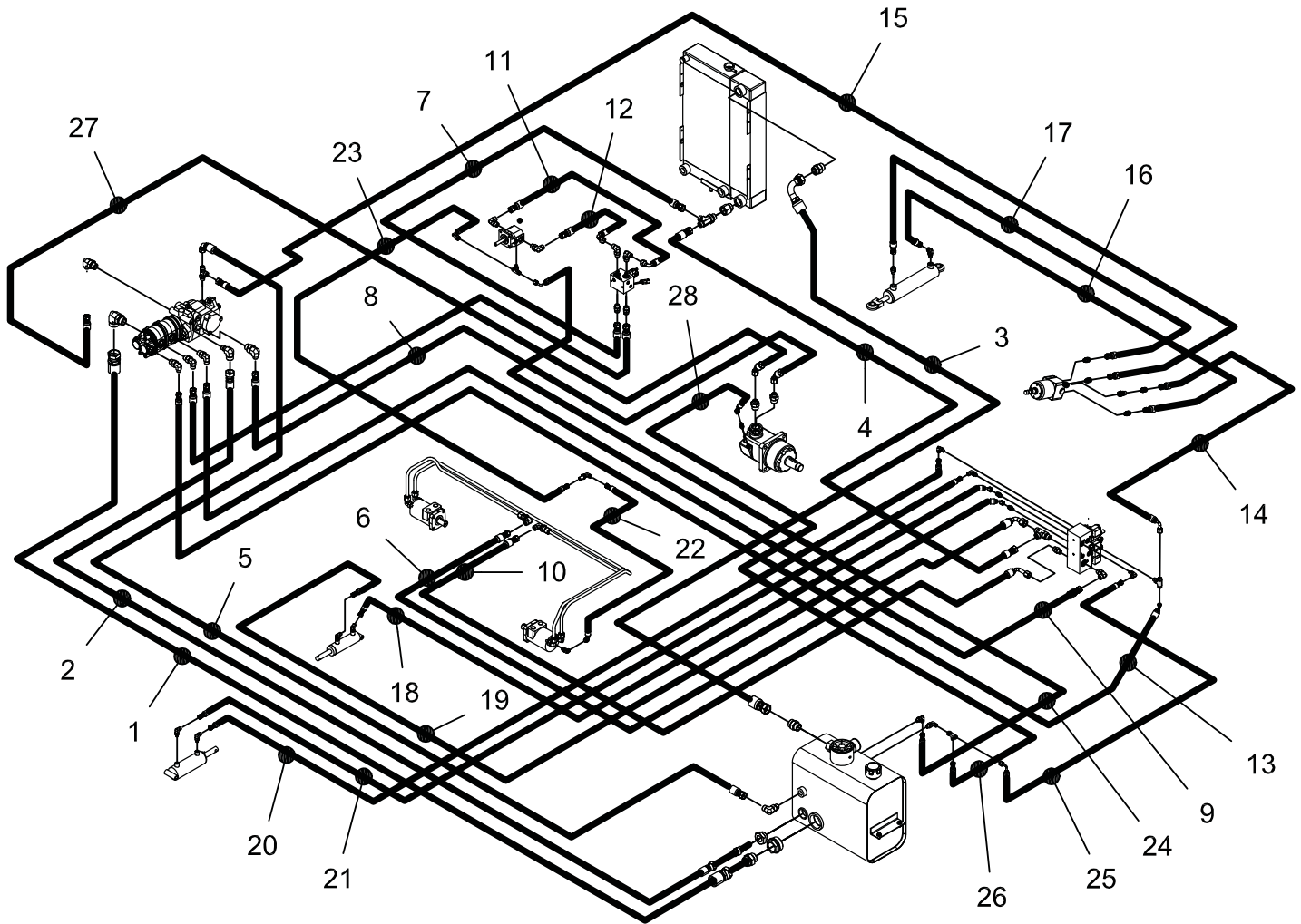

REV C

HYDRAULIC HOSE GROUP (730148)

Parts List 730148			
ITEM	PART NUMBER	QTY	DESCRIPTION
1	731051	1	HOSE, 20 STR - 20 STR SUC (RES TO AUX PUMP IN)
2	731052	1	HOSE, 12 STR - 12 STR SUC (RES TO VDP CASE)
3	731053	1	HOSE, 16 STR - 16 90 RET (COOLER UPPER TO RES)
4	731054	1	HOSE, 10 STR - 10 STR RET (VALVE T2 TO COOLER)
5	731055	1	HOSE, 10 STR - 8 90 RET (VDP CASE TO RES)
6	731056	1	HOSE, 8 STR - 10 90 MED (MB LEFT TO VALVE T2)
7	731057	1	HOSE, 8 STR - 10 STR MED (IMP SOL T TO COOLER)
8	731058	1	HOSE, 8 STR - 8 STR MED (AUX PUMP 2 TO IMP SOL P)
9	731059	1	HOSE, 8 STR - 8 STR MED (AUX PUMP 1 TO VALVE P2)
10	731060	1	HOSE, 8 STR - 8 90 MED (VALVE MB OUT TO MB RIGHT)
11	731061	1	HOSE, 8 STR - 8 90 MED (IMP SOL VF OUT TO IMP LEFT)
12	731062	1	HOSE, 8 STR - 8 90 MED (IMP RIGHT TO IMP SOL VF IN)
13	731063	1	HOSE, 6 STR - 6 45 MED (AUX PUMP 3 TO VALVE P1)
14	731064	1	HOSE, 6 STR - 6 90 MED (VALVE P1 TO STR PRESS)
15	731065	1	HOSE, 6 STR - 8 STR RET (STR TANK TO VDP CASE)
16	731066	1	HOSE, 6 STR - 6 STR MED (STR LEFT TO CYL F)
17	731067	1	HOSE, 6 STR - 6 STR MED (STR RIGHT TO CYL R)
18	731068	1	HOSE, 4 STR - 4 45 MED (VALVE BL A TO SH CYL F)
19	731069	1	HOSE, 4 STR - 4 45 MED (VALVE BL B TO SH CYL R)
20	731070	1	HOSE, 4 STR - 4 STR MED (VALVE SG B TO SQU CYL F)
21	731071	1	HOSE, 4 STR - 4 STR MED (VALVE SG A TO SQU CYL R)
22	731072	1	HOSE, 4 STR - 4 45 MED (MB CASE TO MB MOTOR)
23	731073	1	HOSE, 4 STR - 4 90 MED (MB CASE TO IMP CASE)
24	731074	1	HOSE, 4 STR - 4 90 MED (IMP CASE TO RES)
25	731075	1	HOSE, 4 STR - 4 90 MED (VALVE T1 TO RES)
26	731076	1	HOSE, 4 STR - 4 45 MED (WHEEL DRIVE CASE TO RES)
27	731077	1	HOSE, 8 STR - 8 45 SPCL (VDP L TO WHEEL DRIVE R)
28	731078	1	HOSE, 8 STR - 8 45 SPCL (VDP R TO WHEEL DRIVE F)

HOSE CLAMP GROUP (730149)

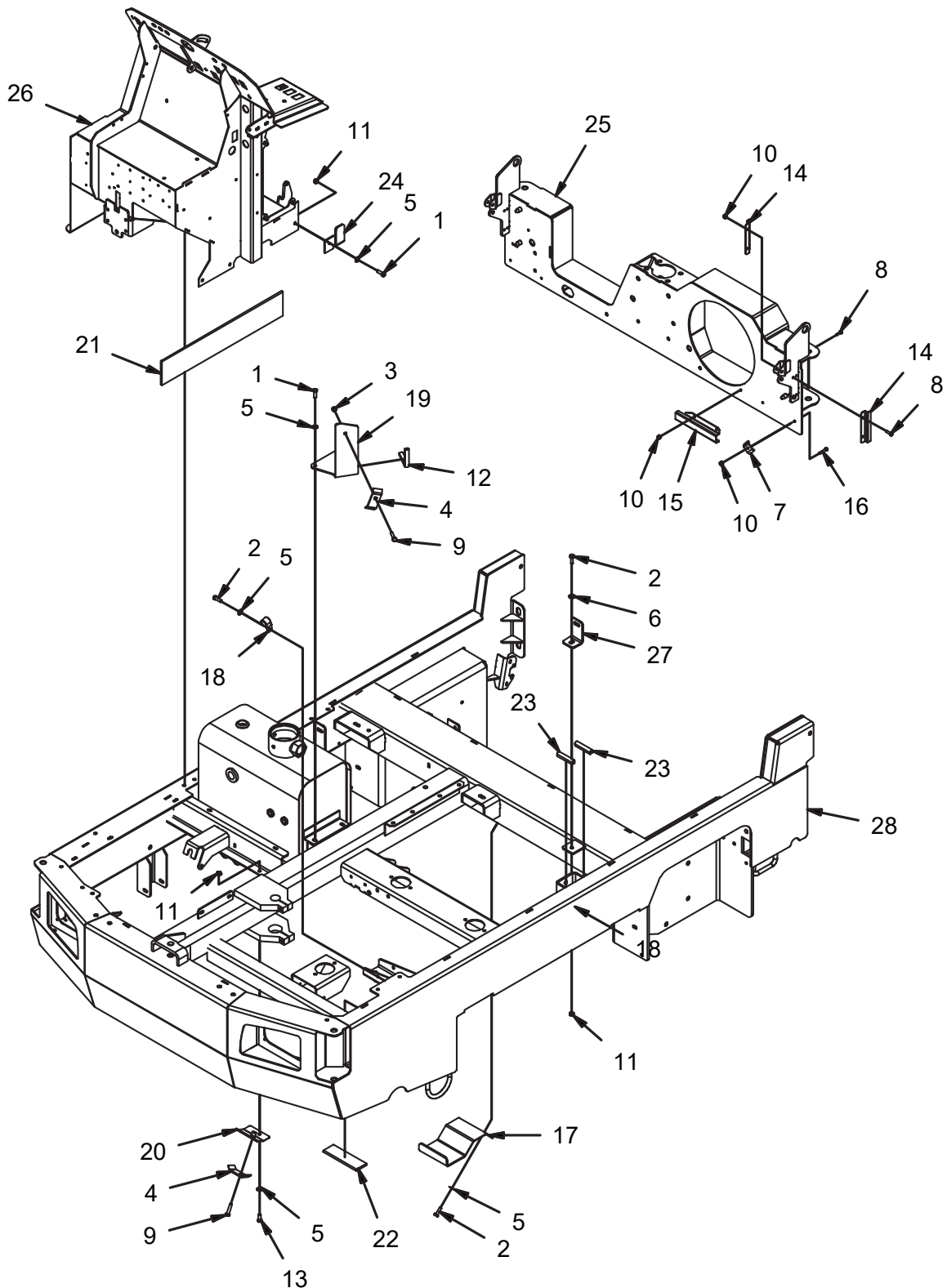

REV B

HOSE CLAMP GROUP (730149)

Parts List			
ITEM	PART NUMBER	QTY	DESCRIPTION
1	11038247	3	BLT-HH M8-1.25 X 25 STL ZINC
2	11039567	4	BOLT, M8-1.25 X 25 HH SS
3	12040259	1	NUT, M8-1.25 ESN SS
4	3305398	2	RETAINER, HOSE, OFFSET, 8
5	3400384	7	WASHER, 5/16 BELLEVILLE
6	3400385	1	WASHER, 3/8, BELLEVILLE
7	600822	1	RETAINER, HOSE, SYM, 6
8	600913	4	BOLT, M6-1.00 X 20 HH SS
9	600918	2	BOLT, M8-1.25 X 35 HH
10	600933	5	NUT, M6-1.00 ESN SS
11	600934	5	NUT, M8-1.25 FLNG
12	620039	1	EDGING, 3/16 X 5.75"
13	717030	1	BOLT, M8-1.25 X 20 HH SS
14	730880	2	HOSE RETAINER, SINGLE
15	730881	1	HOSE RETAINER, DOUBLE
16	731050	1	BOLT, M6-1.00 X 30 HH SS
17	731145	1	BRACKET, HOSE TRAY
18	731146	2	CLAMP, HOSE, .88
19	731147	1	TRAY, REAR HOSE
20	731148-1	1	ASSEMBLY, HOSE CLAMP BRACKET
21	731150	1	SLEEVE, AS-B-37 X 30.0"
22	731151	1	SLEEVE, AS-B-17 X 6.0"
23	731152	2	EDGING, .31 X 2.75"
24	731153	1	BRACKET, CENTER HOSE
25	REF.	-	BUMPER
26	REF.	-	CONSOLE
27	REF.	-	BRACKET, TANK MNT
28	REF.	-	FRAME

DECAL GROUP (730150)

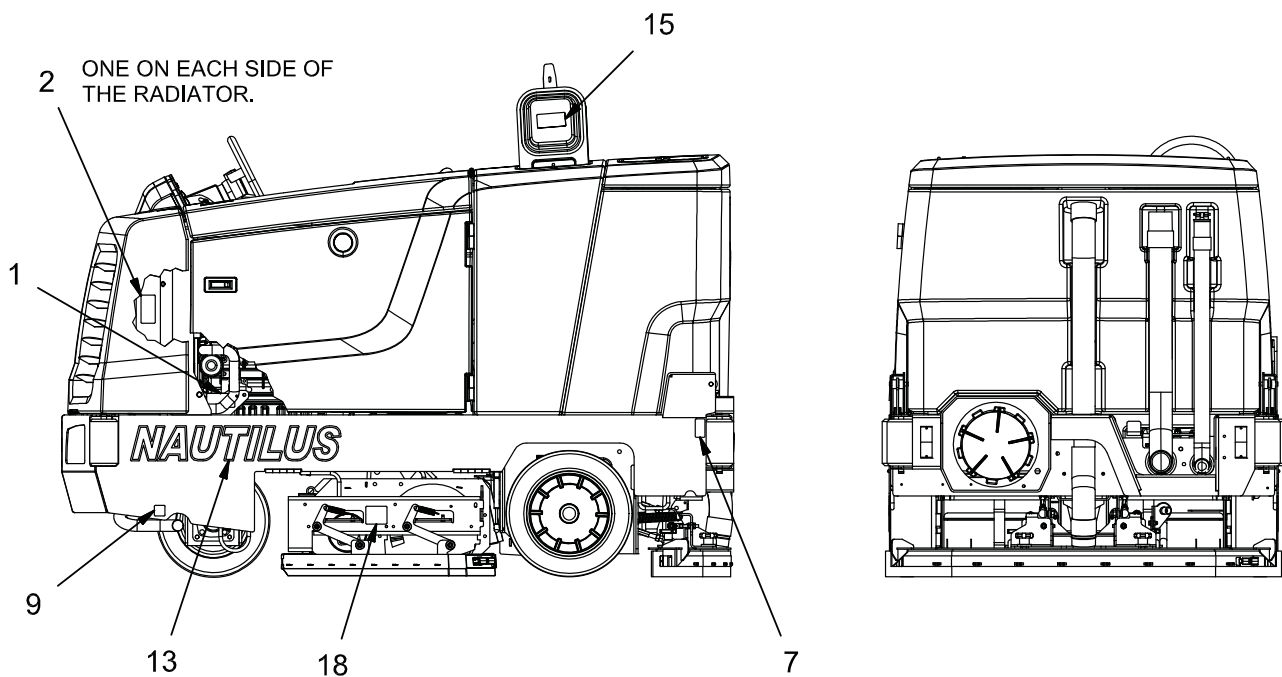
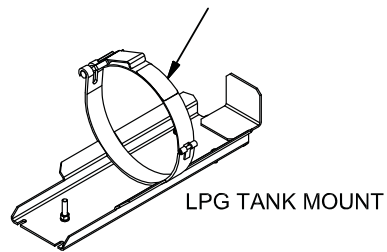
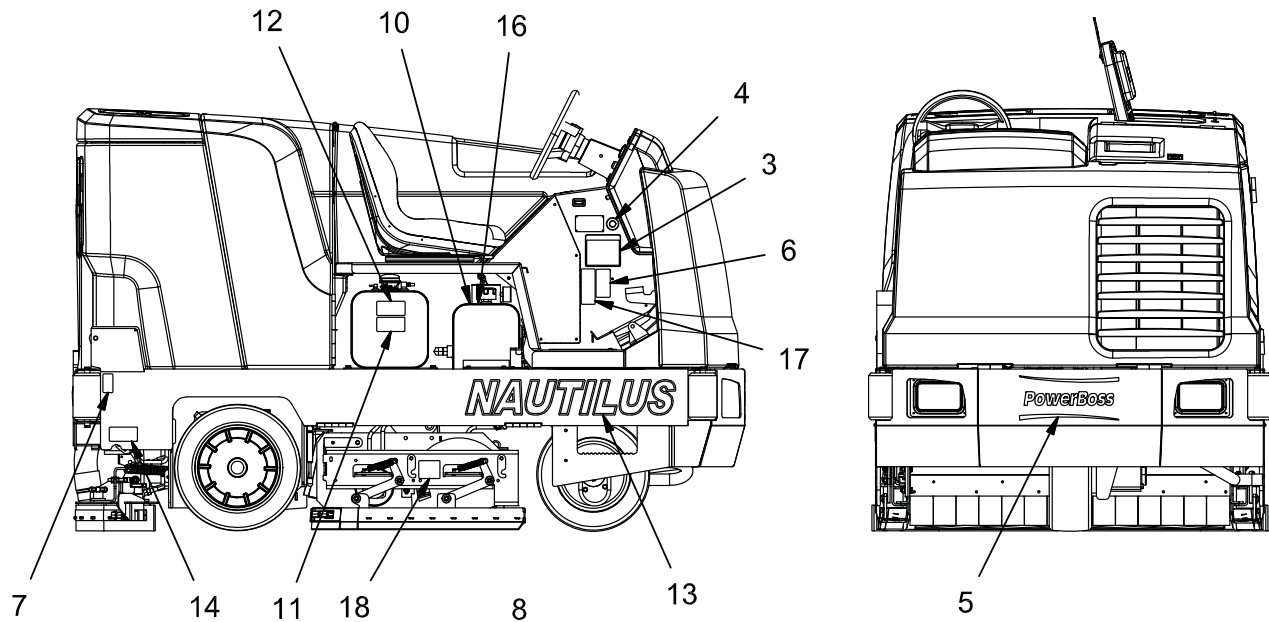

REV A

DECAL GROUP (730150)

Parts List DECAL GROUP 730150			
ITEM	PART NUMBER	QTY	DESCRIPTION
1	3301730	1	DECAL, WARNING FAN BELT (ENG)
2	3301733	2	DECAL, WARNING FAN (RAD SHROUD)
3	3301854	1	DECAL, CAUTION
4	3334827	1	DECAL, MADE IN USA
5	3334900	1	DECAL, POWERBOSS
6	3342264	1	DECAL, READ MANUAL
7	3342650	2	DECAL, PINCH POINT
8	3342971	1	DECAL, LPG FUEL TANK (LPG ONLY)
9	3342978	1	DECAL, HOT SURFACE
10	715023	1	DECAL, HYDRAULIC FLUID INFORMATION
11	715949	1	DECAL, GAS FUEL WARNING (GAS MACHINE ONLY)
12	715953	1	DECAL, DIESEL FUEL WARNING (DIESEL MACHINE ONLY)
13	715962	2	DECAL, NAUTILUS
14	715963	1	DECAL, BUMPER LATCH
15	715965	1	DECAL, FLAMMABLE MATERIAL WARNING
16	715966	1	DECAL, WARNING, NO FUEL IN RES.
17	715967	1	DECAL, WARNING, DO NOT PICK UP
18	715968	2	DECAL, WARNING, ROTATING BRUSHES

ELECTRICAL GROUP (730116)

NOTE:

THERE IS NO PICTURE AVAILABLE FOR THIS GROUP

REV *

ELECTRICAL GROUP (730116)

Parts List			
ITEM	PART NUMBER	QTY	DESCRIPTION
1	748990	1	ENGINE HARNESS
2	748991	1	LIGHTS HARNESS
3	748992	1	MAIN HARNESS
4	748799	1	HARNESS, MAIN, NAUTILUS
5	731146	2	CLAMP, HOSE, .88

BRUSH/BROOM GROUP (730175)

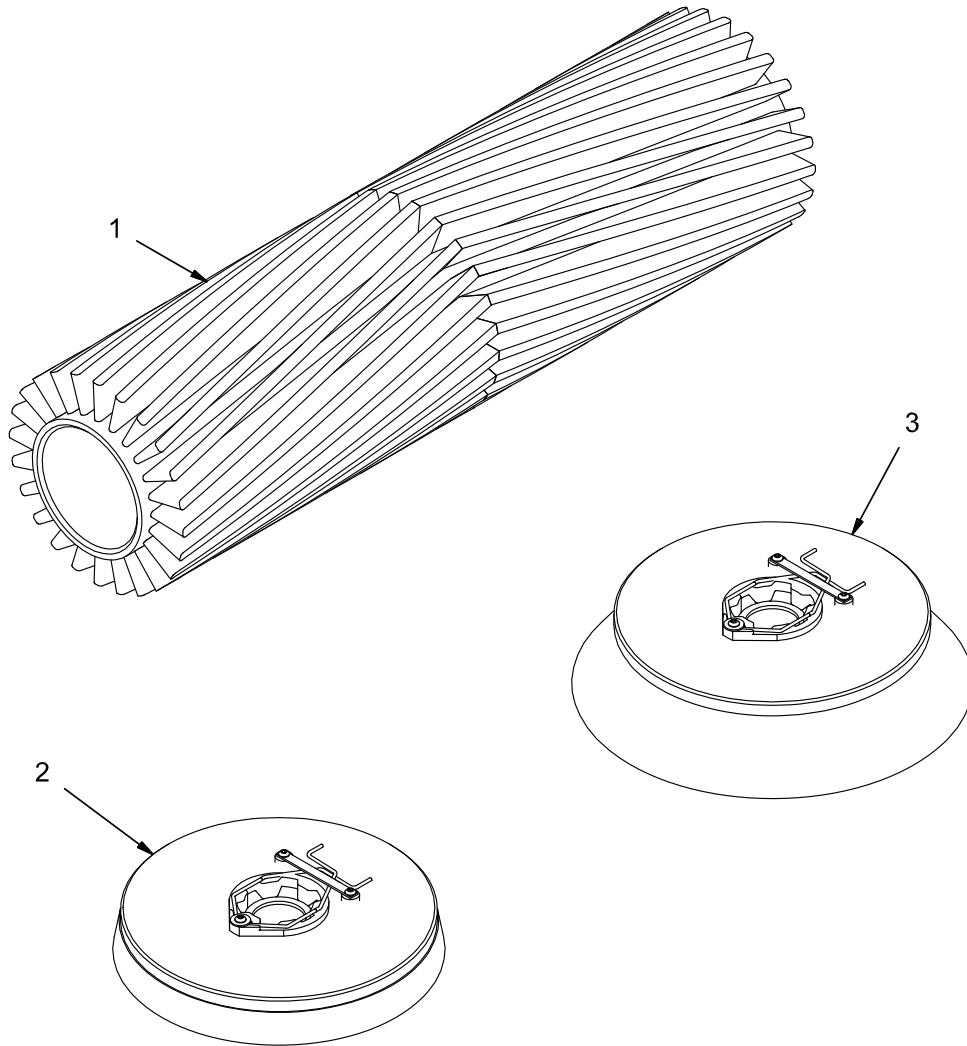

REV B

BRUSH/BROOM GROUP (730175)

Parts List - 730175			
ITEM	PART NUMBER	QTY	DESCRIPTION
1	731090	1	BRUSH, CYLINDRICAL, 45", NYLON
1	731091	1	BRUSH, CYLINDRICAL, 45", POLY
1	731092	1	BRUSH, CYLINDRICAL, 45", 80 GRIT ABRASIVE
1	731093	1	BRUSH, CYLINDRICAL, 45", 180 GRIT ABRASIVE
1	731268	1	BRUSH, CYLINDRICAL, 45", HIGH DENSITY NYLON
1	731269	1	BRUSH, CYLINDRICAL, 45", HIGH DENSITY POLY
1	731270	1	BRUSH, CYLINDRICAL, 45", HIGH DENSITY 80 GRIT
1	731271	1	BRUSH, CYLINDRICAL, 45", HIGH DENSITY 180 GRIT
2	3313128	1	BRUSH, DISC, 16", PURPLE
2	3313126	1	BRUSH, DISC, 16", BLACK
2	3332545	1	BRUSH, DISC, 16", BLUE
2	3315385	1	BRUSH, DISC, 16", RED
2	3313136	1	BRUSH, DISC, 16", NYLON
3	731259	1	SIDE BROOM, 20", POLY

OPTIONS - PARTS BREAKDOWN

OPTION - SIDE BRUSH GROUP (730000)

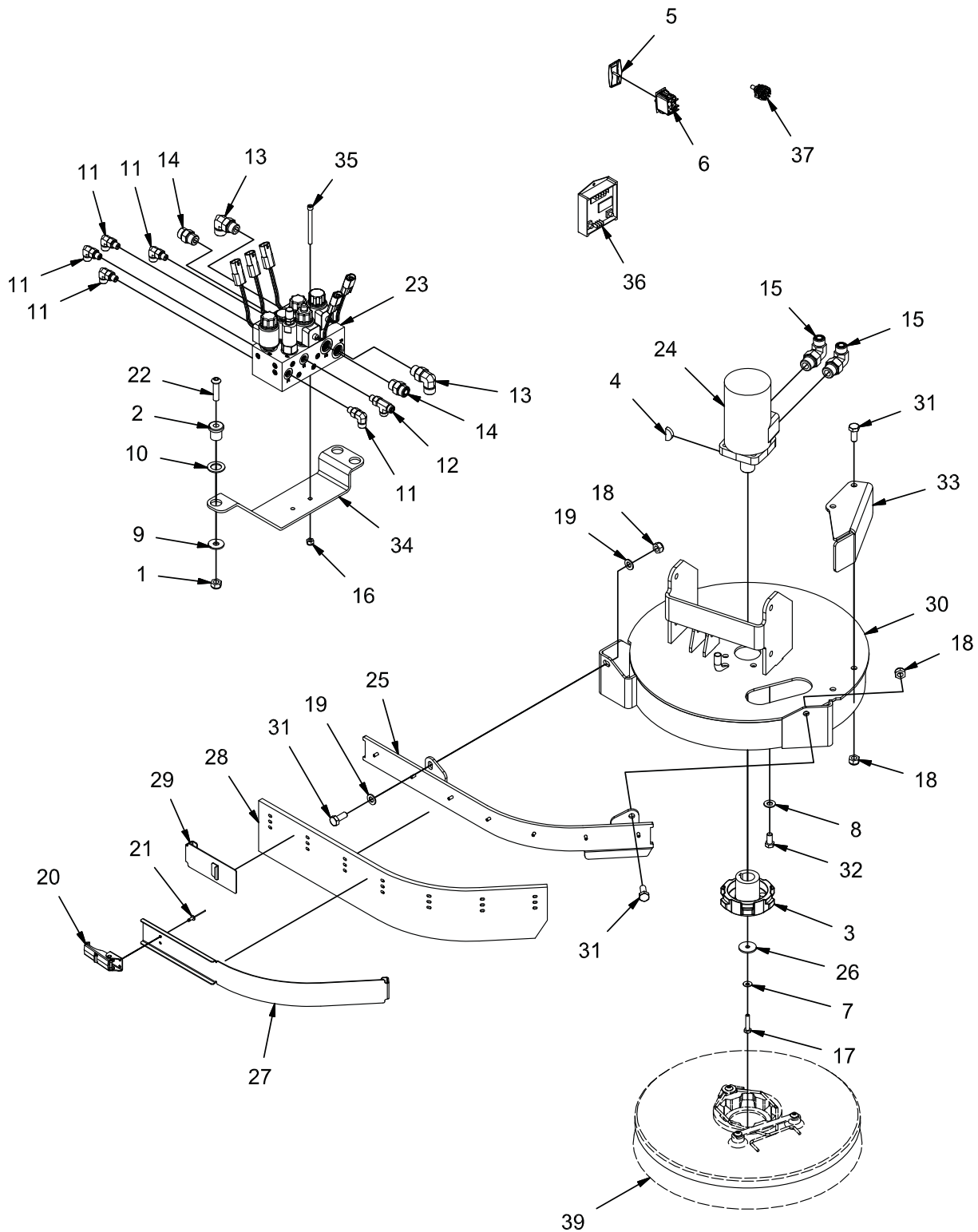

REV B

OPTION - SIDE BRUSH GROUP (730000)

Parts List 730000			
ITEM	PART NUMBER	QTY	DESCRIPTION
1	12040069	3	NUT, M10-1.50 ESN
2	3300465	3	ISOLATOR, VIB
3	3324451	1	HUB, DRIVE
4	3330338	1	KEY, WOODRUFF .25 X .50
5	3342273	1	SWITCH COVER - BLACK, CLEAR LENS
6	3342705	1	SWITCH, DPST
7	3400383	1	WASHER, 1/4 BELLEVILLE
8	3400385	4	WASHER, 3/8, BELLEVILLE
9	600363	3	WASHER, ISOLATOR
10	66-431-A	3	WASHER, .77 B 1.25 OD .075 T
11	675507	5	FITTING, 90, -4 ORFS - 4 SAE
12	675509	1	FITTING, RUN TEE -4 ORFS TO -4 SAE
13	675523	2	FITTING, 90, -8 ORFS - 8 SAE
14	675524	2	FITTING, STR, -8 ORFS - 8 SAE
15	675528	2	FITTING, 90, -8 ORFS - 10 SAE
16	711373	2	NUT, FIBER INSERT 1/4-20
17	712566	1	SCREW, 1/4-20 X 1.25 HH SS
18	730339	4	NUT, M10-1.50 ESN SS
19	730344	2	WASHER, M10 SS
20	730652	1	LATCH, UNDER CENTER
21	730654	2	RIVET,BLIND, .156 D X .062 - .125 GRIP SS
22	730698	3	BOLT, M10-1.50 X 40 BUTTON HD CAP
23	730795	1	MANIFOLD, SSB
24	730892	1	MOTOR, 9.7 DISP
25	730927	1	WELDMENT, SSB SQU MNT
26	730933	1	WASHER, .28 B, 1.25 OD, .105 T SS
27	730938	1	SSB SQU RETAINER
28	730939	1	SSB SQUEEGEE
29	730940	1	WELDMENT, SSB REAR RET
30	730942	1	WELDMENT, SSB MOUNT
31	730958	4	BOLT, M10-1.50 X 25 HH SS
32	730959	4	SCREW, 3/8-16 X .750 HHC SS
33	730963	1	WELDMENT, SSB GUARD
34	730964	1	MOUNT, SSB MANIFOLD
35	730965	2	BOLT, 1/4-20 X 3.00 SOC HD CAP
36	731126	1	PROPORTIONAL VALVE DRIVER - DOUBLE
37	748796	1	DUAL BRUSH PRESSURE SELECTOR
38	748798	1	HARNESS, SIDE BRUSH
39	REF.	-	SCRUB BRUSH, 16 D

**GROUP (730036) - OPTION SIDE SCRUB BRUSH, INCLUDES SUB-GROUPS:
730000, 730001, 730002, 730011, 730028, 730029, 730171**

OPTION - SIDE BRUSH LIFT GROUP (730001)

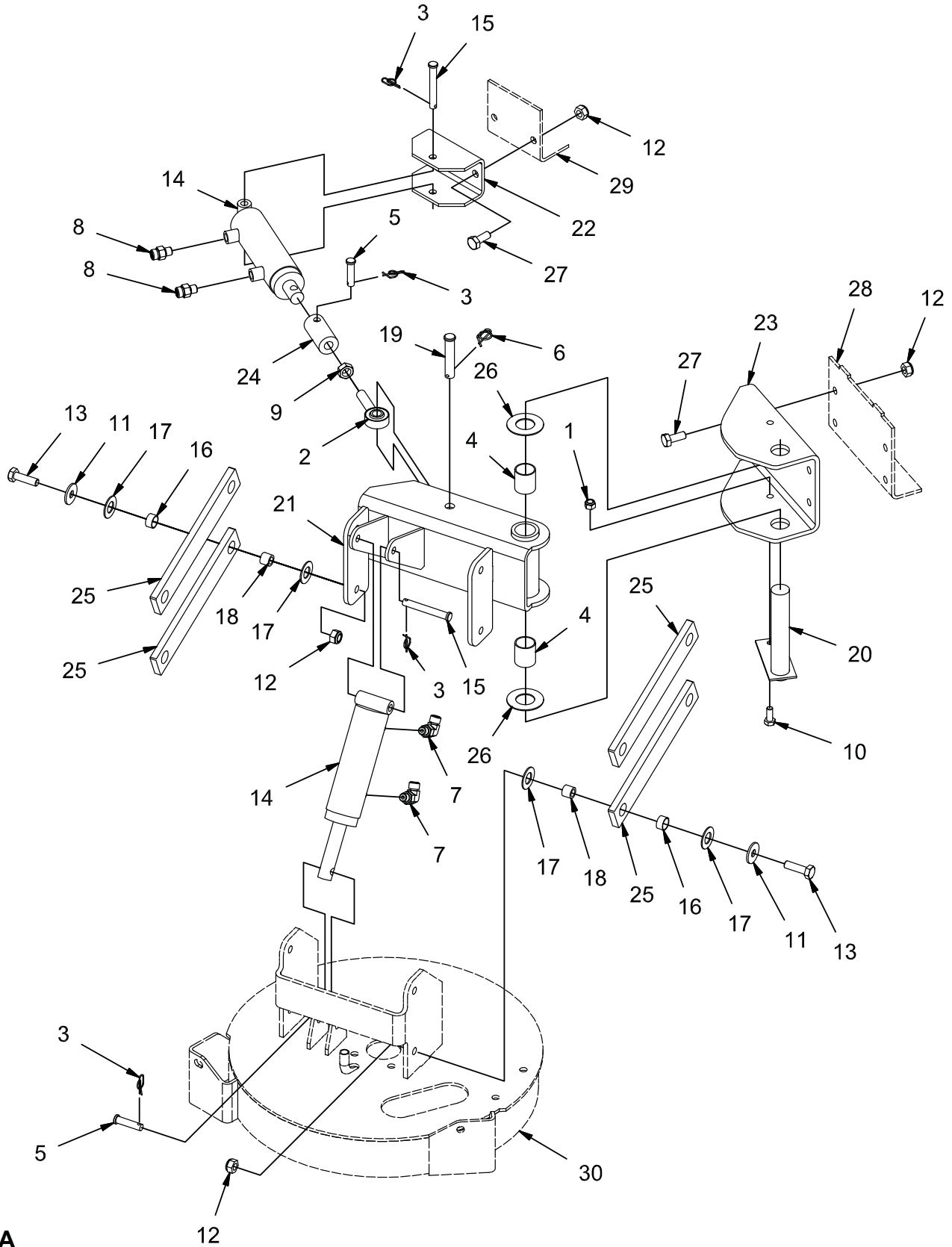

REV A

OPTION - SIDE BRUSH LIFT GROUP (730001)

Parts List 730001			
ITEM	PART NUMBER	QTY	DESCRIPTION
1	12040259	1	NUT, M8-1.25 ESN SS
2	3311977	1	ROD END, MALE, 1/2-20
3	3400125	4	RUE-RING, .375
4	600174	2	BEARING, FIBERGLIDE 1.00 ID 1.25 T
5	600573	2	PIN, CLEVIS, 3/8 X 1.50
6	600578	1	RUE-RING, .50
7	675507	2	FITTING, 90, -4 ORFS - 4 SAE
8	675508	2	FITTING, STR, 4 ORFS - 4-SAE
9	711337	1	NUT, HEX JAM 1/2-20
10	717030	1	BOLT, M8-1.25 X 20 HH SS
11	717040	8	WASHER, FENDER, .413 B 1.18 OD .098 T SS
12	730339	14	NUT, M10-1.50 ESN SS
13	730345	8	BOLT, M10-1.50 X 35 HH SS
14	730548	2	CYLINDER, HYD, 1.50 B X 2.88 STK
15	730602	2	PIN, CLEVIS, .375 X 2.75
16	730646	8	BEARING, DU, .63 B .72 OD .38 T
17	730647	16	WASHER, THRUST, .66 B 1.25 OD .06 T
18	730648	8	SPACER, .406 B .624 OD .515 T SS
19	730875	1	PIN, CLEVIS 1/2 X 2.50 ZP
20	730907	1	WELDMENT, PIN
21	730910	1	WELDMENT, SSB ARM
22	730923	1	SSB CYL MNT
23	730924	1	SSB MNT
24	730925	1	SSB ADJ TUBE
25	730926-1	4	SSB LINK
26	730957	2	WASHER, THRUST, 1.03 B 2.00 OD .063 T
27	730958	6	BOLT, M10-1.50 X 25 HH SS
28	REF.	-	FRAME
29	REF.	-	FRAME
30	REF.	-	SSB MOUNT

**GROUP (730036) - OPTION SIDE SCRUB BRUSH, INCLUDES SUB-GROUPS:
730000, 730001, 730002, 730011, 730028, 730029, 730171**

OPTION - SIDE BRUSH SOLUTION CONTROL GROUP (730002)

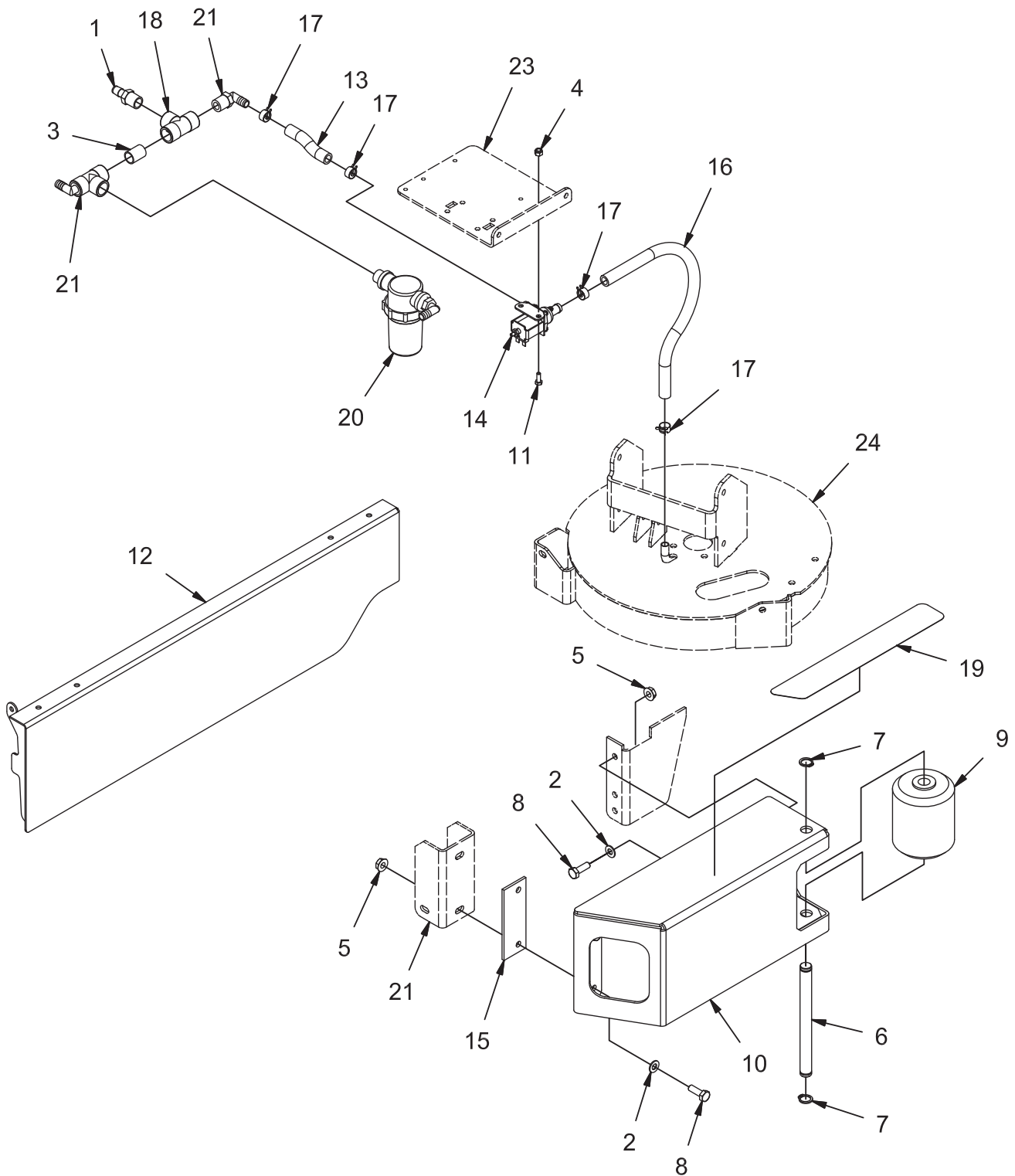

REV A

OPTION - SIDE BRUSH SOLUTION CONTROL GROUP (730002)

Parts List 730002			
ITEM	PART NUMBER	QTY	DESCRIPTION
1	3315534	1	FITTING, PLASTIC, STR, .50 NPT .50 BARB
2	3400385	4	WASHER, 3/8, BELLEVILLE
3	383465	1	1/2 NPT CLOSE PIPE NIPPLE, BRASS
4	600933	2	NUT, M6-1.00 ESN SS
5	600936	4	NUT, M10-1.50 FLNG
6	730876	1	PIN, ROLLER
7	730877	2	RETAINING RING, EXT, .750
8	730878	4	BOLT, M10-1.50 X 30 HH SS
9	730915	1	ROLLER, SSB
10	730916	1	WELDMENT, SSB GUARD
11	730934	2	BOLT, M6-1.00 X 16 HH SS
12	730952	1	WELDMENT, SSB DOOR
13	730954	1	TUBING, .50 ID X .13 WALL BRAIDED VINYL
14	730956	1	VALVE, SOLENOID, 12V, ADJ
15	730960	1	SPACER PLT
16	730961	1	TUBING, .50 ID X .13 WALL BRAIDED VINYL
17	730962	4	CLAMP, WIRE HOSE
18	730966	1	FITTING, PVC TEE, FEMALE 1/2 NPT
19	730967	1	PAD, STEP
20	REF.	-	FILTER AND STD FITTING COMPONENTS
21	REF.	-	FRAME
22	REF.	-	FRAME
23	REF.	-	BRACKET, FILTER MNT
24	REF.	-	SSB MOUNT

**GROUP (730036) - OPTION SIDE SCRUB BRUSH, INCLUDES SUB-GROUPS:
730000, 730001, 730002, 730011, 730028, 730029, 730171**

OPTION - SIDE BRUSH HYDRAULIC HOSE GROUP (730011)

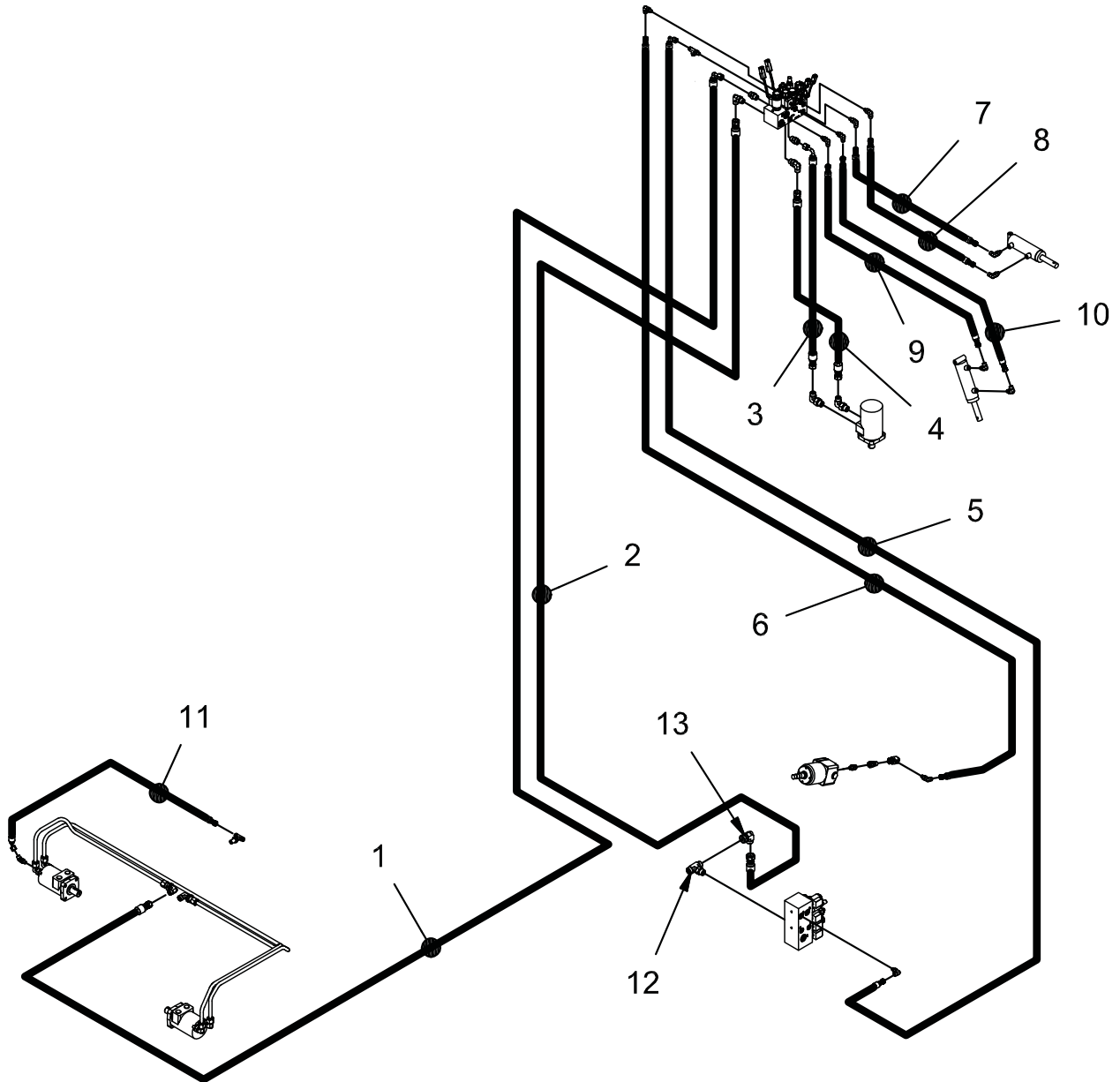

REV D

OPTION - SIDE BRUSH HYDRAULIC HOSE GROUP (730011)

Parts List 730011			
ITEM	PART NUMBER	QTY	DESCRIPTION
1	731079	1	HOSE, 8 STR - 8 90 MED (LH MB TO SSB VALVE P2)
2	731081	1	HOSE, 10 STR - 8 45 MED (VALVE T2 TO SSB VALVE T2)
3	731082	1	HOSE, 8 STR - 8 90 MED (SSB VALVE SB OUT TO SB R)
4	731083	1	HOSE, 8-STR - 8 STR MED (SSB VALVE SB IN TO SB F)
5	731084	1	HOSE, 4-STR - 4 STR MED (STR TEE TO SSB VALVE P1)
6	731085	1	HOSE, 4 STR - 4 90 MED (VALVE T1 TO SSB VALVE T1)
7	731087	1	HOSE, 4 STR - 4 STR MED (SSB VALVE SBE B TO EXT CYL R)
8	731088	1	HOSE, 4 STR - 4 STR MED (SSB VALVE SBL A TO LIFT CYL U)
9	731089	1	HOSE, 4 STR - 4 STR MED (SSB VALVE SBE A TO EXT CYL L)
10	731089	1	HOSE, 4 STR - 4 STR MED (SSB VALVE SBL B TO LIFT CYL L)
11	731168	1	HOSE, 4 STR - 4 45 MED (LH MB CASE TO SCRUB HEAD TEE)
12	675623	1	FTG - BRANCH TEE -10 ORFS TO -10 ORFS TO -10 SAE
13	675624	1	FTG - SWIVEL NUT ELBOW -10 ORFS TO -10 ORFS

**GROUP (730036) - OPTION SIDE SCRUB BRUSH, INCLUDES SUB-GROUPS:
730000, 730001, 730002, 730011, 730028, 730029, 730171**

OPTION - SIDE BRUSH SCRUB HEAD GROUP (730028)

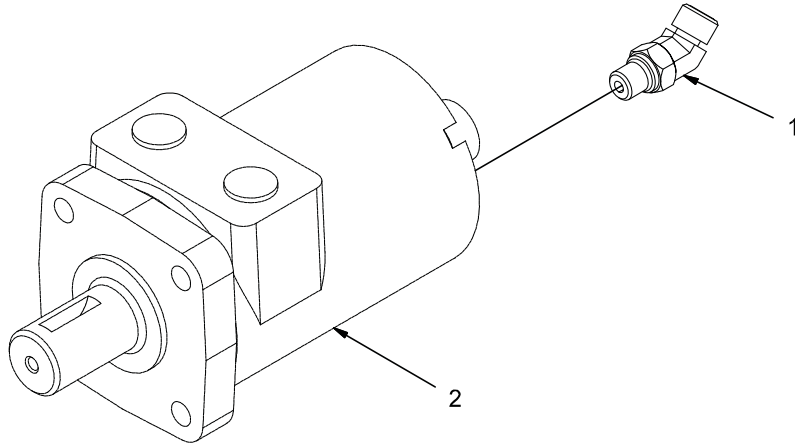

Parts List 730112			
ITEM	PART NUMBER	QTY	DESCRIPTION
1	675541	1	FITTING, 45, 4 ORFS - 4 SAE
2	REF.	-	LEFT SCRUB BRUSH MOTOR, 4.5 DISP

**GROUP (730036) - OPTION SIDE SCRUB BRUSH, INCLUDES SUB-GROUPS:
730000, 730001, 730002, 730011, 730028, 730029, 730171**

REV *

OPTION - SIDE BRUSH STEERING COLUMN GROUP (730029)

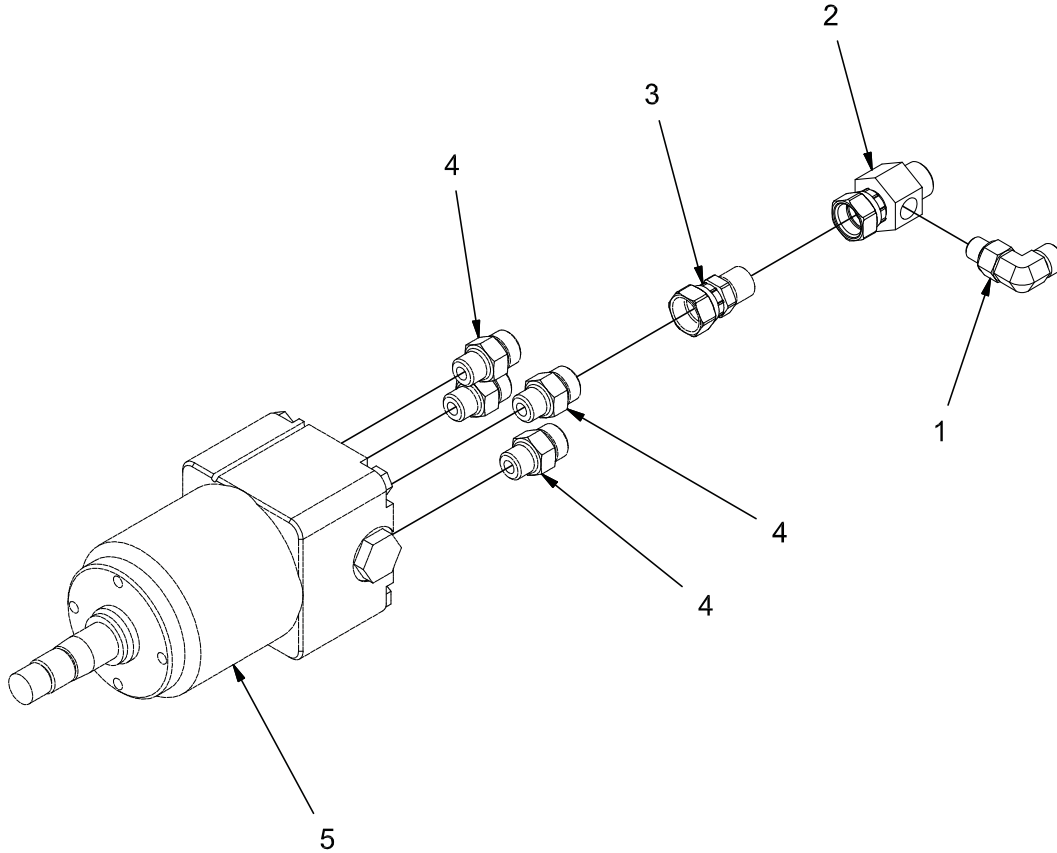

Parts List			
ITEM	PART NUMBER	QTY	DESCRIPTION
1	675507	1	FITTING, 90, -4 ORFS - 4 SAE
2	675604	1	FTG-TEE -6 ORFS TO -6 ORFS TO -4 SAE
3	REF.	-	FTG - .094 ORIFICE ADAPTER -6 ORFS TO -6 ORFS
4	REF.	-	FITTING, STR, 6 ORFS - 6 SAE
5	REF.	-	STEERING UNIT

REV *

OPTION - SSB HYDRAULIC MANIFOLD GROUP (730171)

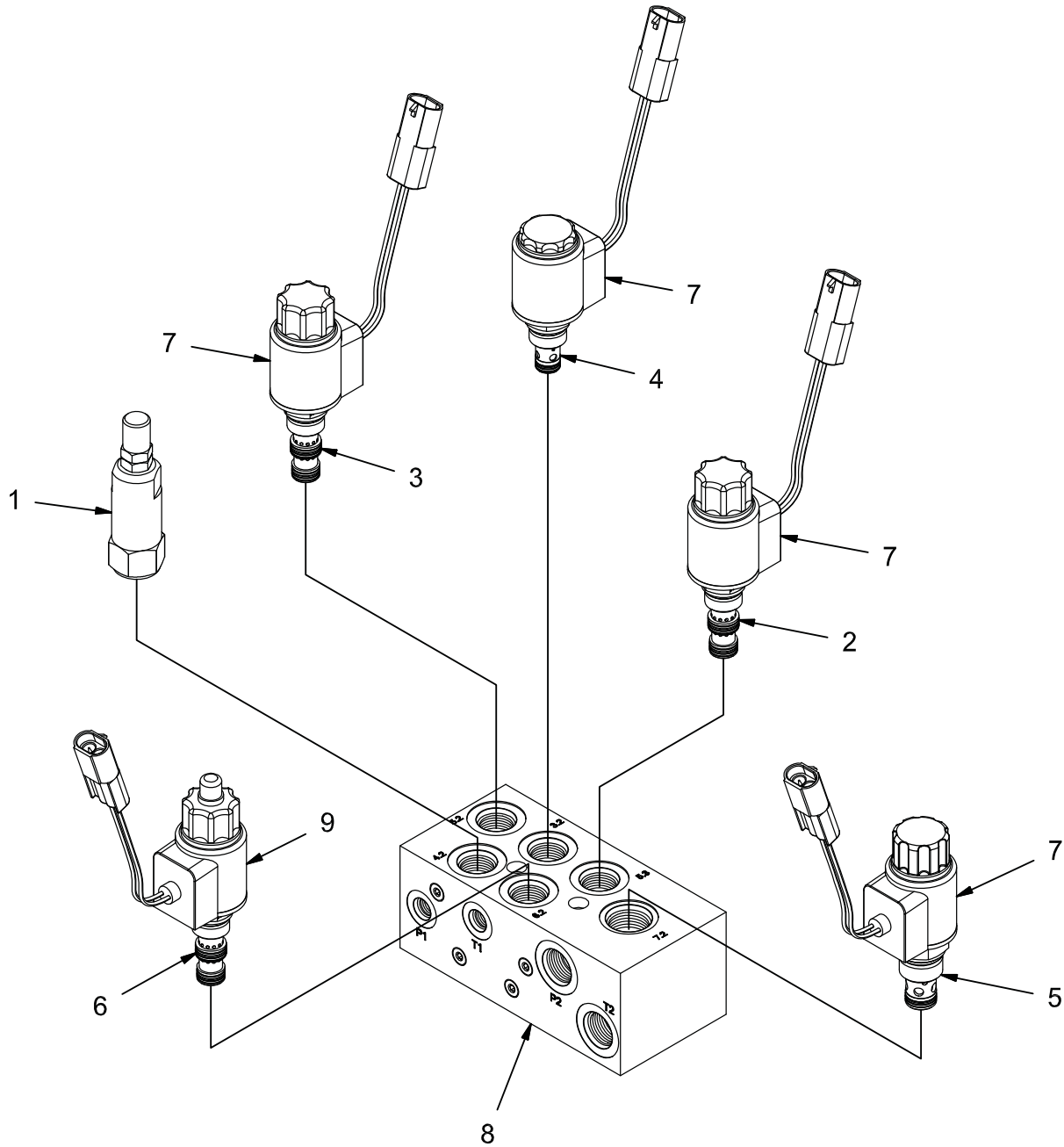

REV B

OPTION - SSB HYDRAULIC MANIFOLD GROUP (730171)

Parts List 730171			
ITEM	PART NUMBER	QTY	DESCRIPTION
1	730702	1	PORT 4.2 - RV4 - PRESSURE REDUCTION VALVE SOL. RED. VALVE, DR08-01-C-N-050-V-45
2	730705	1	PORT 5.3 - SV10 - SIDE BRUSH DOWN SOL. VALVE, WK08L-01-C-N-0
3	730705	1	PORT 5.2 - SV12 - SIDE BRUSH EXTEND SOL. VALVE, WK08L-01-C-N-0
4	730707	1	PORT 3.2 - SV11 - SIDE BRUSH UP - LOCK SOL. VALVE, WS08ZR-01-C-N-0
5	730709	1	PORT 7.2 - SV8 - SIDE BRUSH ON SOL. VALVE, WS10Y-01-C-N-0
6	730710	1	PORT 6.2 - SV9 - SIDE BRUSH FORCE PROP. RED. VALVE, PDR08-01-M-C-N-070
7	731122	4	COIL, 12V, 3003124
8	731123	1	MANIFOLD BLOCK, SSB
9	731226	1	COIL, PROPORTIONAL, 12PL-2.2-40-1836

**GROUP (730036) - OPTION SIDE SCRUB BRUSH, INCLUDES SUB-GROUPS:
730000, 730001, 730002, 730011, 730028, 730029, 730171**

OPTION - OVERHEAD GUARD GROUP (730003)

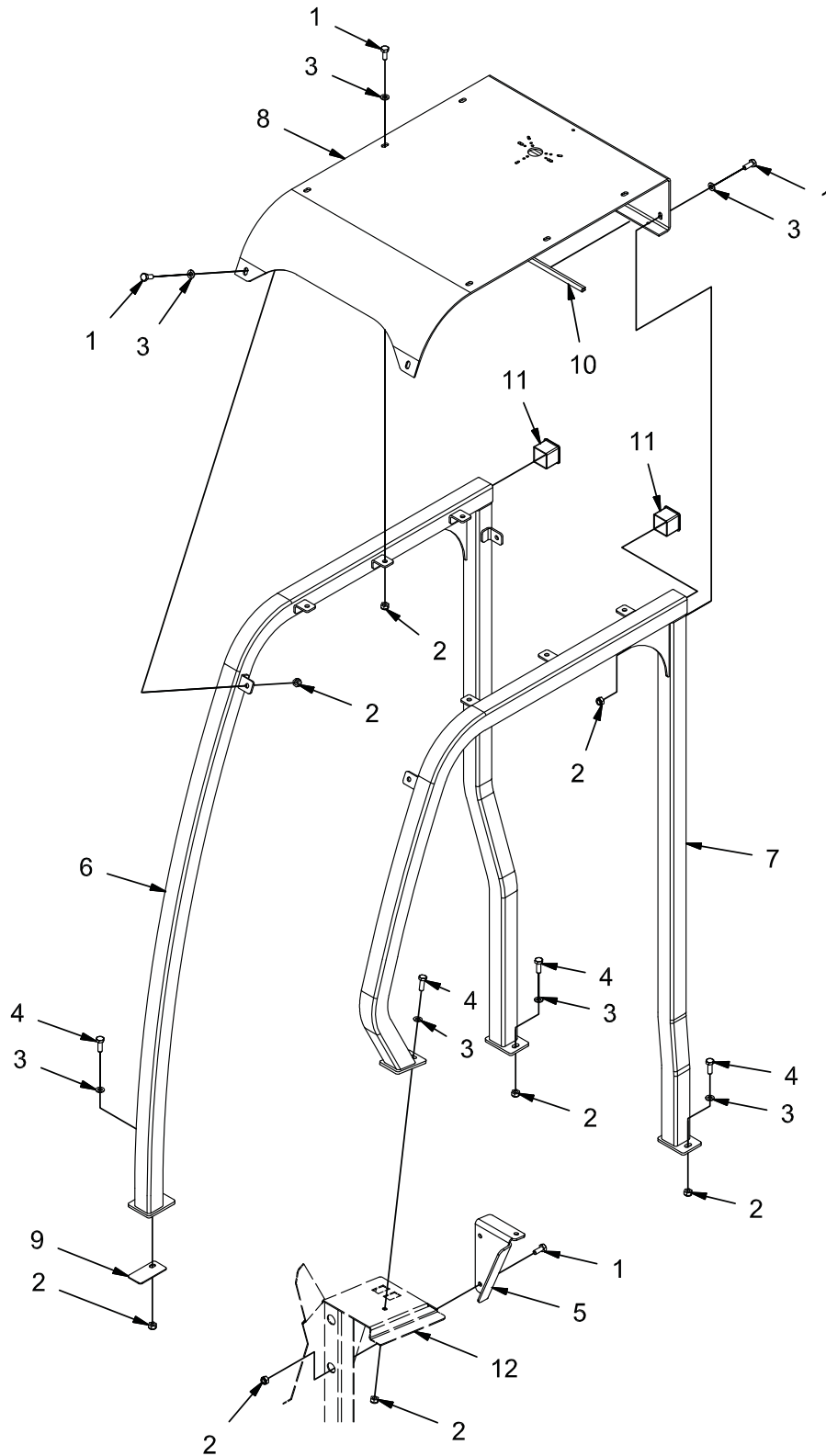

REV *

OPTION - OVERHEAD GUARD GROUP (730003)

Parts List - 730003			
ITEM	PART NUMBER	QTY	DESCRIPTION
1	11038346	12	BOLT, M10-1.50 X 25 HH
2	12040069	16	NUT, M10-1.50 ESN
3	12310058	14	WASHER, M10
4	3401051	4	BOLT, M10-1.50 X 30 HH
5	730697	1	BRACKET, OHG
6	731012	1	WELDMENT, OHG, RH SIDE
7	731020	1	WELDMENT, OHG, LH SIDE
8	731024	1	OHG, TOP PLT
9	731026	1	PLATE, SPACER
10	731027	1	EDGING, 3/16 X 23.62"
11	731028	2	PLUG, TUBING
12	REF.	-	CONSOLE

OPTION - STROBE LIGHT GROUP (ON OVERHEAD GUARD) (730004)

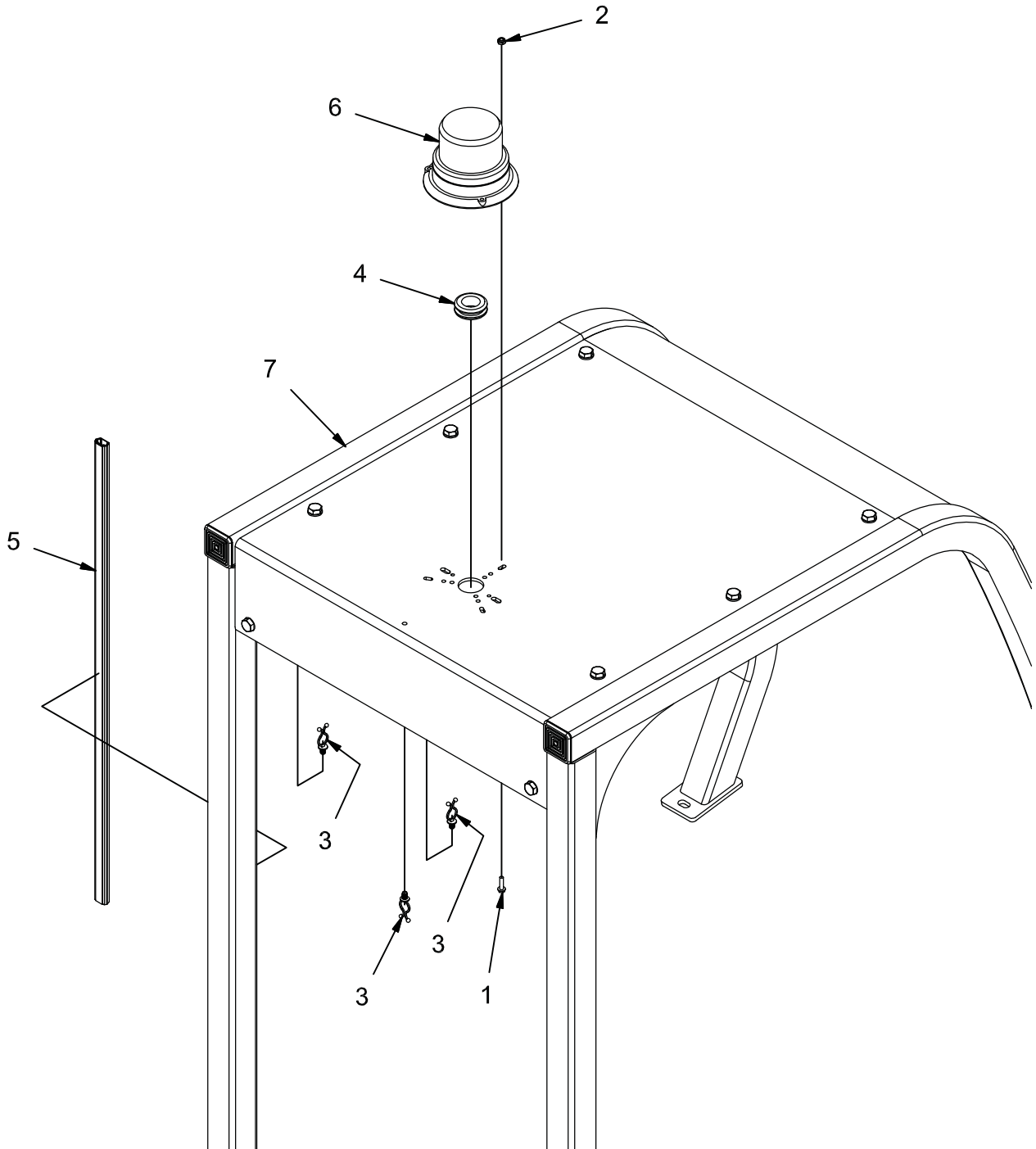

REV B

OPTION - STROBE LIGHT GROUP (ON OVERHEAD GUARD) (730004)

Parts List - 730004			
ITEM	PART NUMBER	QTY	DESCRIPTION
1	3400044	3	SCR-HEX,#10-32 X 0.75 ZP
2	3400172	3	NUT, 10-32 ESN
3	600581	3	CLAMP, WIRE CLIP
4	620160	1	GROMMET, 1.00 ID .1.375 OD .25 T
5	731029	1	WIRE CHANNEL
6	748918	1	ASSEMBLY, AMBER STROBE LIGHT
7	REF.	-	OVERHEAD GUARD
	748981	1	HARNESS, SAFETY LIGHT, OHG

OPTION - ROTATING LIGHT GROUP (ON OVERHEAD GUARD) (730005)

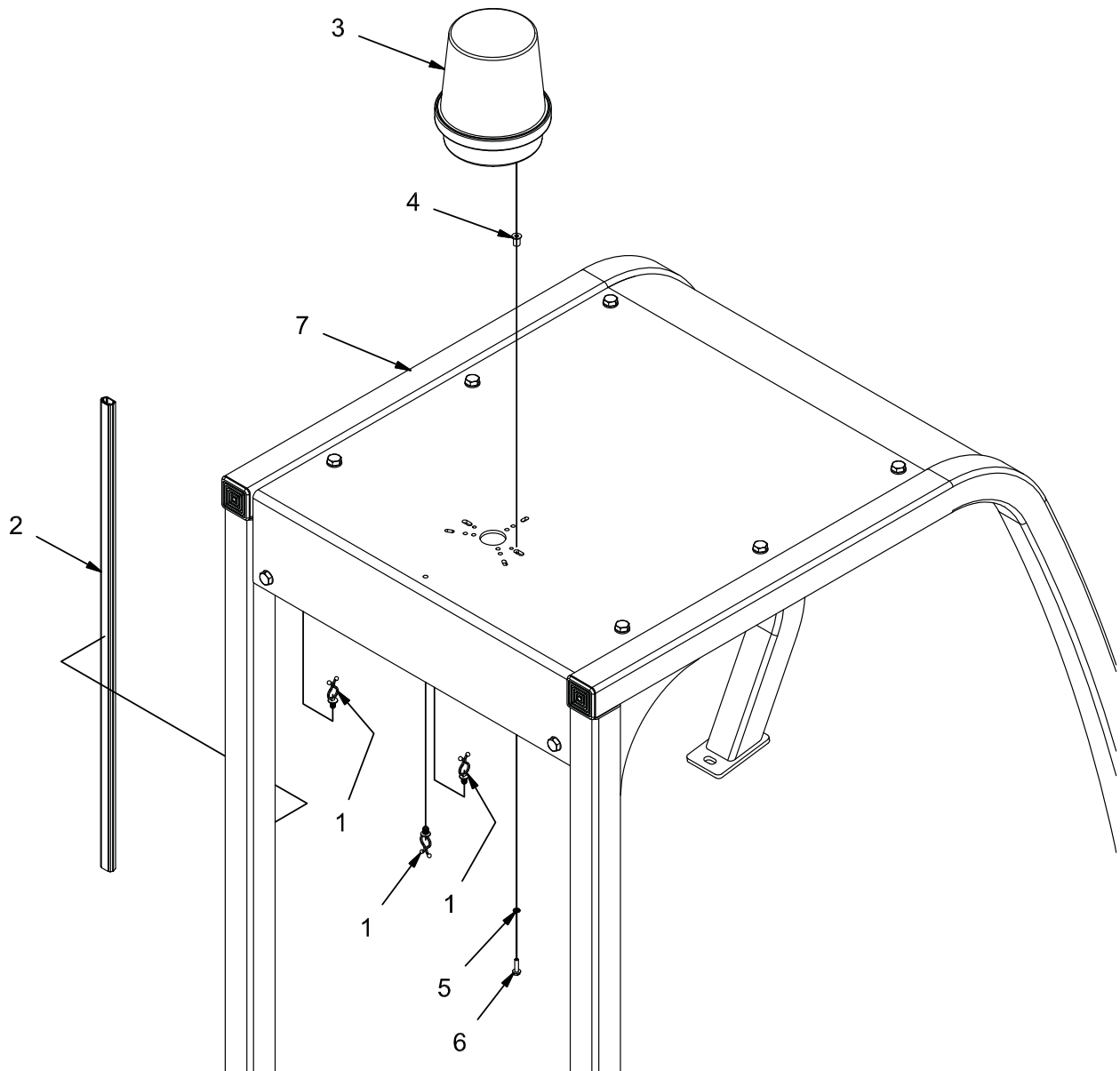

REV B

OPTION - ROTATING LIGHT GROUP (ON OVERHEAD GUARD) (730005)

Parts List - 730005			
ITEM	PART NUMBER	QTY	DESCRIPTION
1	600581	3	CLAMP, WIRE CLIP
2	731029	1	WIRE CHANNEL
3	748919	1	ASSEMBLY, AMBER ROTATING LIGHT
4	PART OF 748919	2	NUT, EXPANSION
5	PART OF 748919	2	STAR WASHER
6	PART OF 748919	2	SCREW
7	REF.	-	OVERHEAD GUARD
	748981	1	HARNESS, SAFETY LIGHT, OHG

OPTION - FLASHING LIGHT GROUP (ON OVERHEAD GUARD) (730006)

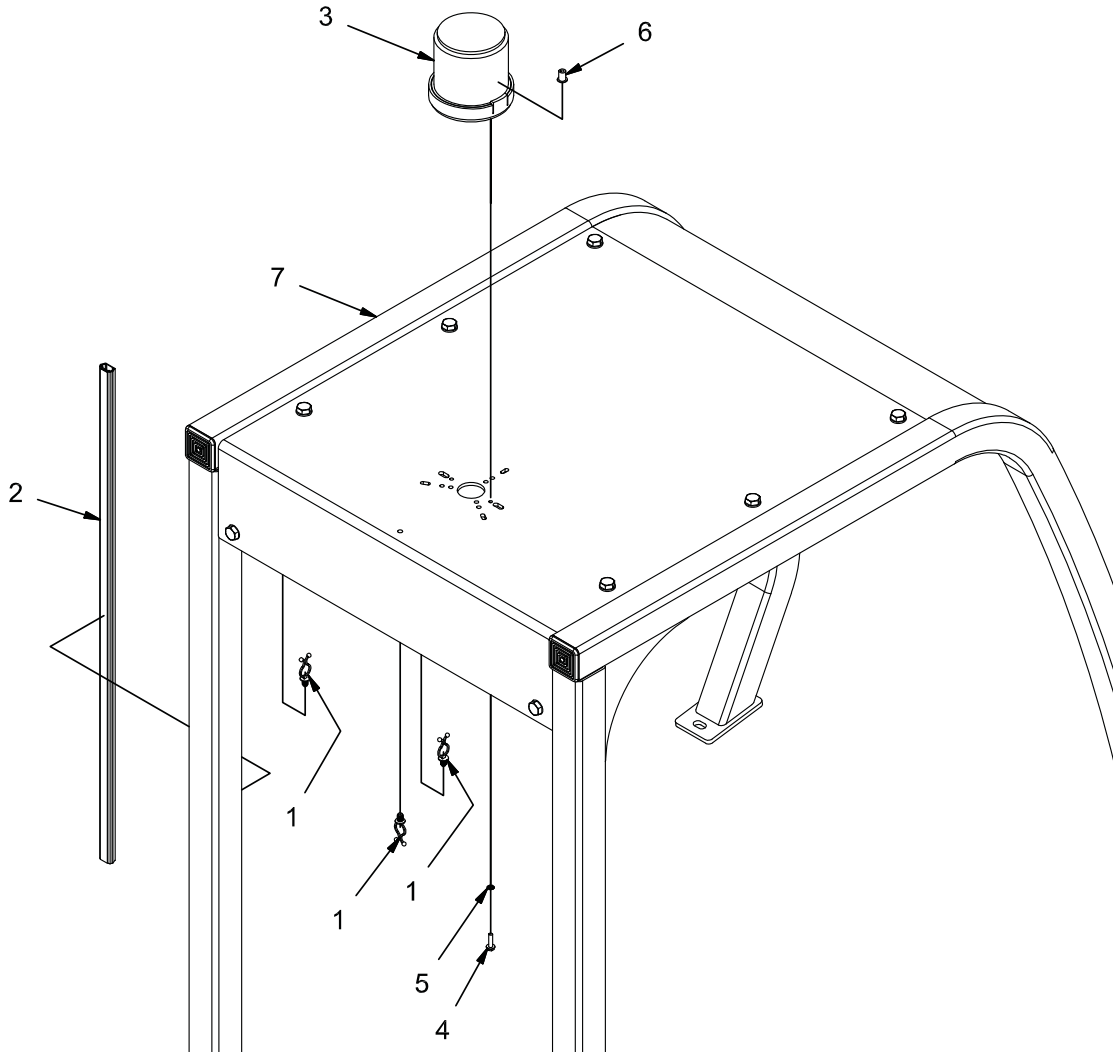

REV B

OPTION - FLASHING LIGHT GROUP (ON OVERHEAD GUARD) (730006)

Parts List - 730006			
ITEM	PART NUMBER	QTY	DESCRIPTION
1	600581	3	CLAMP, WIRE CLIP
2	731029	1	WIRE CHANNEL
3	748920	1	ASSEMBLY, AMBER FLASHING LIGHT
4	PART OF 748920	2	SCREW
5	PART OF 748920	2	STAR WASHER
6	PART OF 748920	2	NUT, EXPANSION
7	REF.	-	OVERHEAD GUARD
	748981	1	HARNESS, SAFETY LIGHT, OHG

OPTION - SUSPENSION SEAT GROUP (730007)

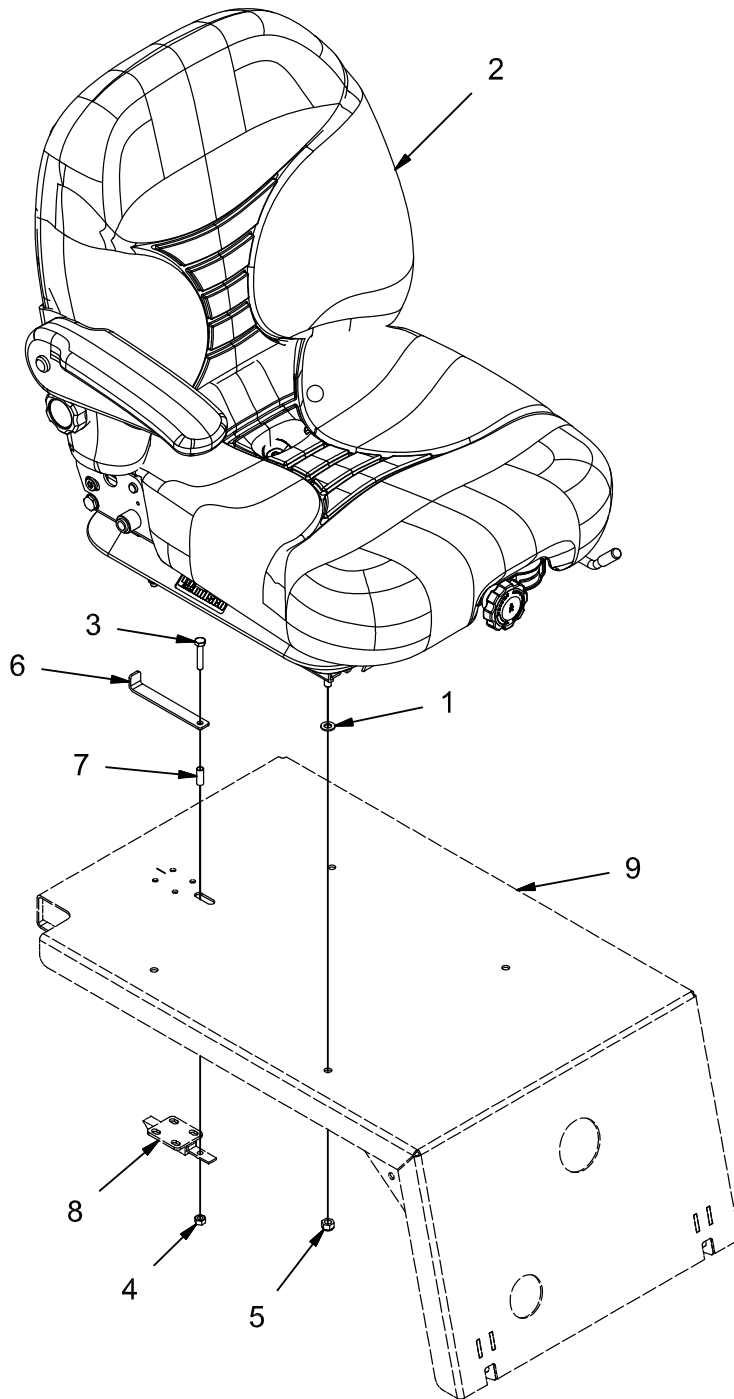

REV A

OPTION - SUSPENSION SEAT GROUP (730007)

Parts List - 730007			
ITEM	PART NUMBER	QTY	DESCRIPTION
1	12310041	4	WASHER, M8
2	620191	1	SEAT, SUSPENSION
3	711211	1	BLT - HH 1/4-20 X 1.38 STL ZINC
4	711316	1	NUT, HEX 1/4-20 ZINC PL
5	711374	4	NUT, FIBER INSERT 5/16-18
6	731262	1	RELEASE, LATCH
7	731263	1	SPACER, .266 B, .313 OD, .813 T
8	REF.	-	SLIDE LATCH
9	REF.	-	SEAT MOUNT

OPTION - BACKUP ALARM GROUP (730008)

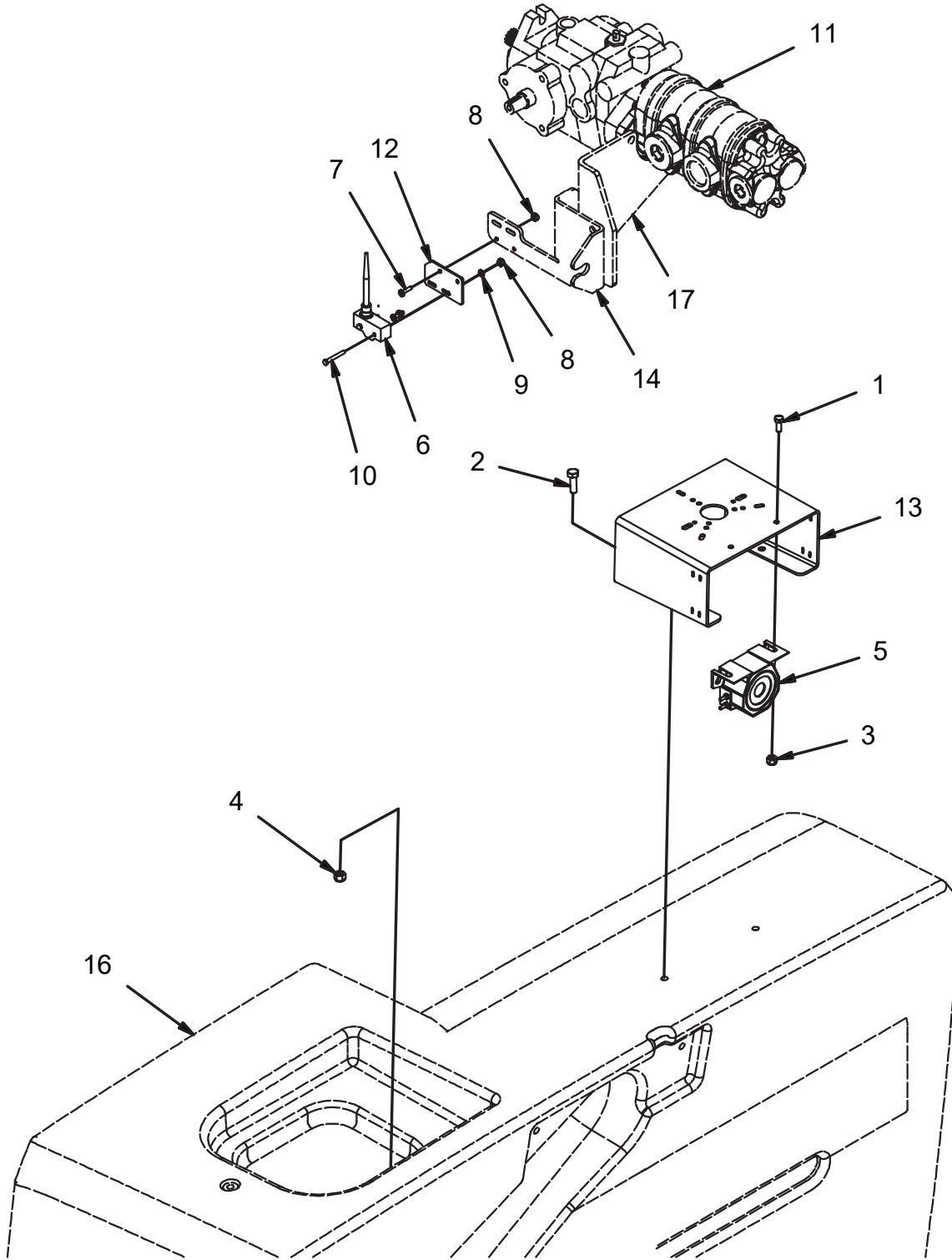

REV C

OPTION - BACKUP ALARM GROUP (730008)

Parts List 730008			
ITEM	PART NUMBER	QTY	DESCRIPTION
1	11038072	2	BOLT, M6-1.00 X 16 HH
2	11039567	2	BOLT, M8-1.25 X 25 HH SS
3	12040044	2	NUT, M6-1.00 ESN
4	12040259	2	NUT, M8-1.25 ESN SS
5	3303002	1	ALARM, BACKUP
6	3342546-1	1	HARNESS, SWITCH, WHISKER
7	3400045	2	SCREW, #8-32 X .625 PAN HD ZP
8	3400082	4	NUT, FIBER INSERT #8-32
9	3400096	2	FLATWASHER, #8
10	620136	2	BOLT, #8-32 X 1.25 HH ZP
11	730310	1	PUMP, AUX
12	731002	1	MOUNT, REVERSE SWITCH
13	731030	1	MOUNT, SAFETY LIGHTS
14	REF.	-	ADJUSTER, HYDROBACK W/SW MNT
15	REF.	-	PUMP ASSEMBLY
16	REF.	-	SOLUTION TANK
17	REF.	-	HYDROBACK MOUNT
	748980	1	HARNESS, SAFETY LT & BACKUP ALARM
	748719	1	HARNESS ASSEMBLY, BACK UP ALARM

OPTION - SEAT BELT (FOR SUSPENSION SEAT) GROUP (730009)

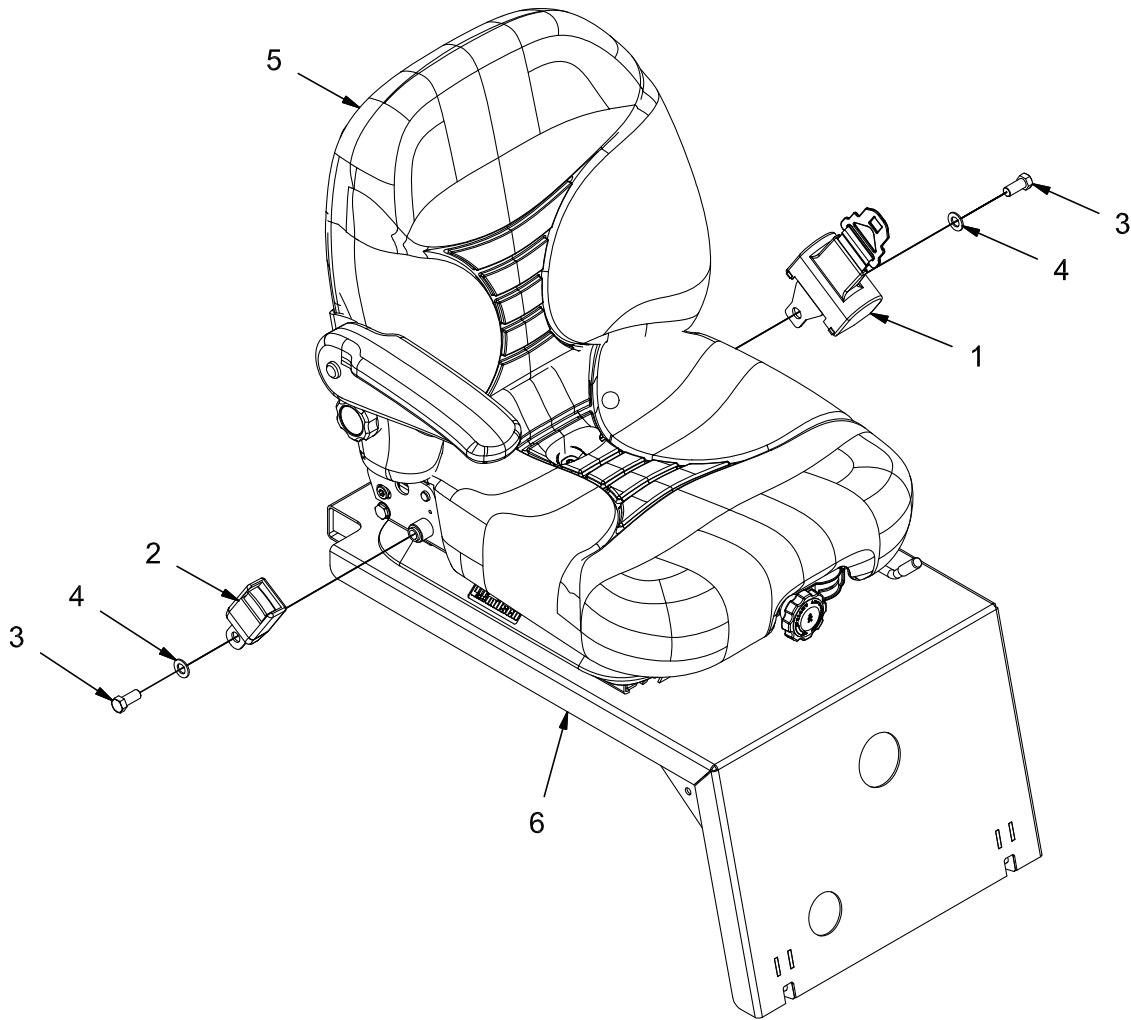

REV *

OPTION - SEAT BELT (FOR SUSPENSION SEAT) GROUP (730009)

Parts List - 730009			
ITEM	PART NUMBER	QTY	DESCRIPTION
1	PART OF 620192	1	SEAT BELT RETRACTOR
2	PART OF 620192	1	SEAT BELT RECEIVER
3	PART OF 620192	2	BOLT, 7/16-20 x 1.00
4	PART OF 620192	2	7/16 FLAT WASHER
-	620192	1	KIT, SEAT BELT
5	REF.	-	SEAT, SUSPENSION
6	REF.	-	SEAT MOUNT

OPTION - SEAT BELT (FOR STANDARD SEAT) GROUP (730010)

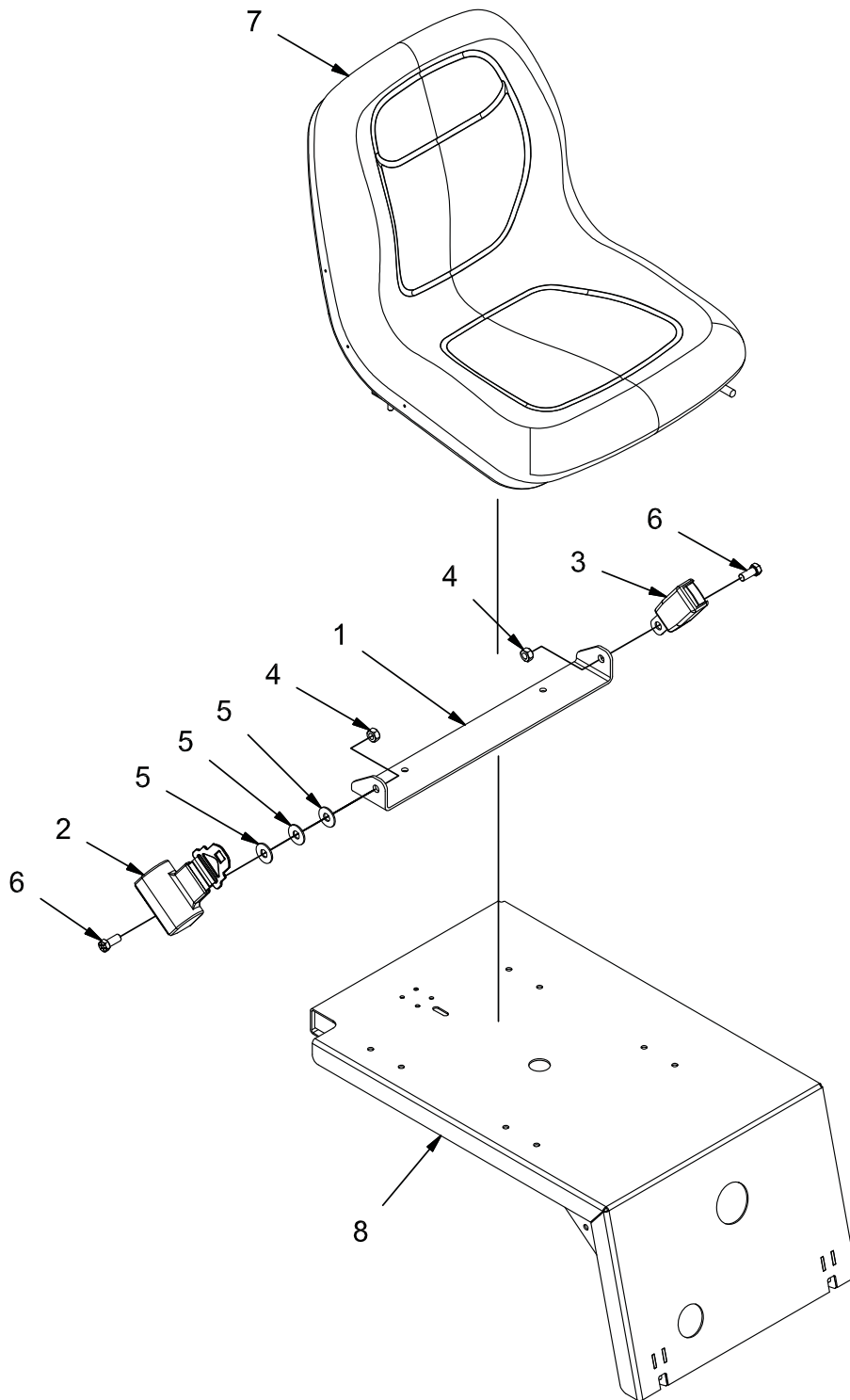

REV *

OPTION - SEAT BELT (FOR STANDARD SEAT) GROUP (730010)

Parts List - 730010			
ITEM	PART NUMBER	QTY	DESCRIPTION
1	620222	1	BRACKET, SEAT BELT
2	PART OF 620192	1	SEAT BELT RETRACTOR
3	PART OF 620192	1	SEAT BELT RECEIVER
4	PART OF 620192	2	NUT, 7/16-20
5	PART OF 620192	3	WASHER
6	PART OF 620192	2	BOLT, 7/16-20
-	620192	1	KIT, SEAT BELT
7	REF.	-	SEAT
8	REF.	-	WELDMENT, SEAT MNT

OPTION - STROBE LIGHT GROUP (ON SOLUTION TANK) (730012)

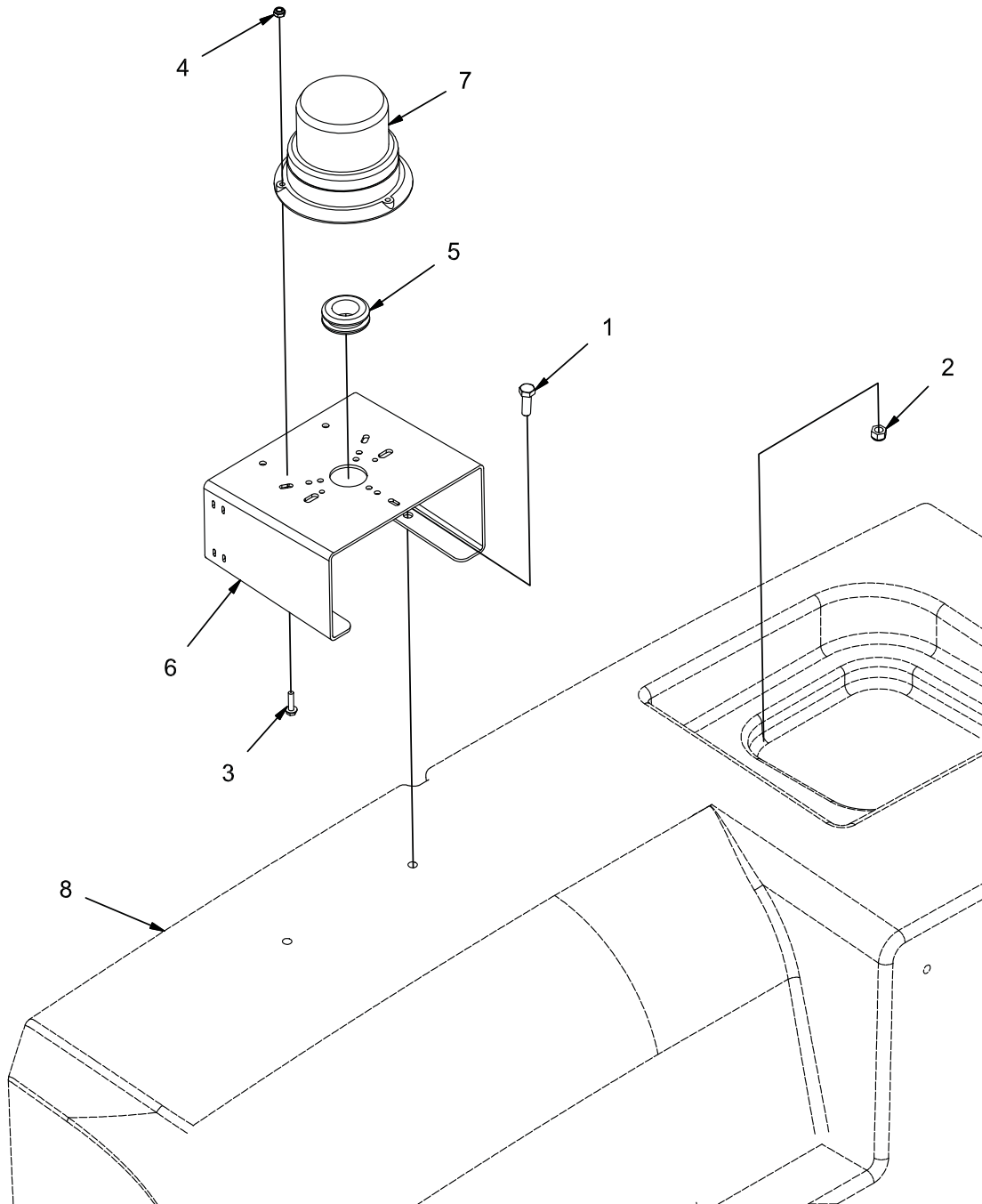

REV B

OPTION - STROBE LIGHT GROUP (ON SOLUTION TANK) (730012)

Parts List 730012			
ITEM	PART NUMBER	QTY	DESCRIPTION
1	11039567	2	BOLT, M8-1.25 X 25 HH SS
2	12040259	2	NUT, M8-1.25 ESN SS
3	3400044	3	SCR-HEX,#10-32 X 0.75 ZP
4	3400172	3	NUT, 10-32 ESN
5	620160	1	GROMMET, 1.00 ID .1.375 OD .25 T
6	731030	1	MOUNT, SAFETY LIGHTS
7	748918	1	ASSEMBLY, AMBER STROBE LIGHT
8	REF.	-	SOLUTION TANK
-	748980	1	HARNESS, SAFETY LIGHT & BACKUP ALARM

OPTION - ROTATING LIGHT GROUP (ON SOLUTION TANK) (730013)

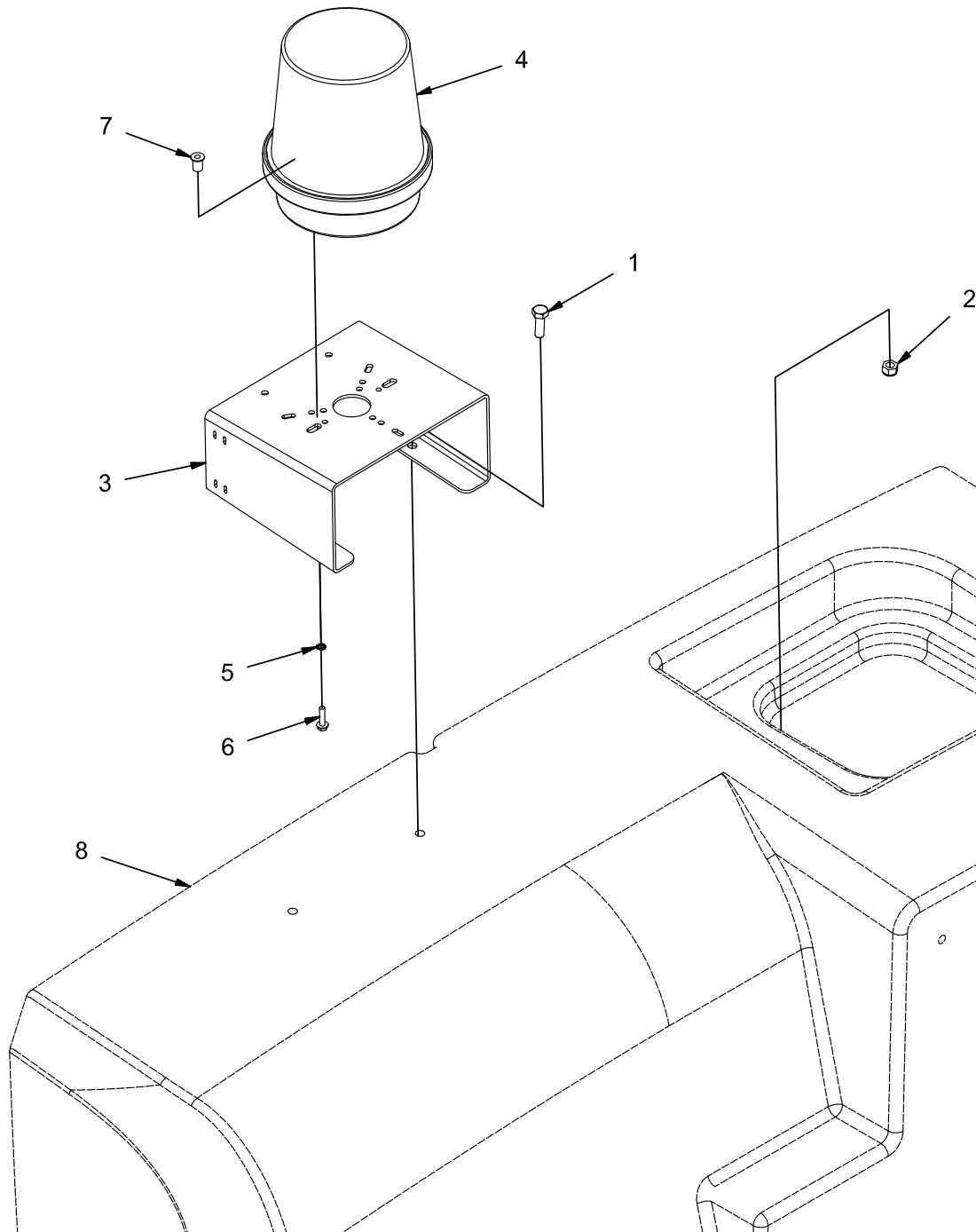

REV B

OPTION - ROTATING LIGHT GROUP (ON SOLUTION TANK) (730013)

Parts List 730013			
ITEM	PART NUMBER	QTY	DESCRIPTION
1	11039567	2	BOLT, M8-1.25 X 25 HH SS
2	12040259	2	NUT, M8-1.25 ESN SS
3	731030	1	MOUNT, SAFETY LIGHTS
4	748919	1	ASSEMBLY, AMBER ROTATING LIGHT
5	PART OF 748919	2	STAR WASHER
6	PART OF 748919	2	SCREW
7	PART OF 748919	2	NUT, EXPANSION
8	REF.	-	SOLUTION TANK
	748980	1	HARNESS, SAFETY LIGHT & BACKUP ALARM

OPTION - FLASHING LIGHT GROUP (ON SOLUTION TANK) (730014)

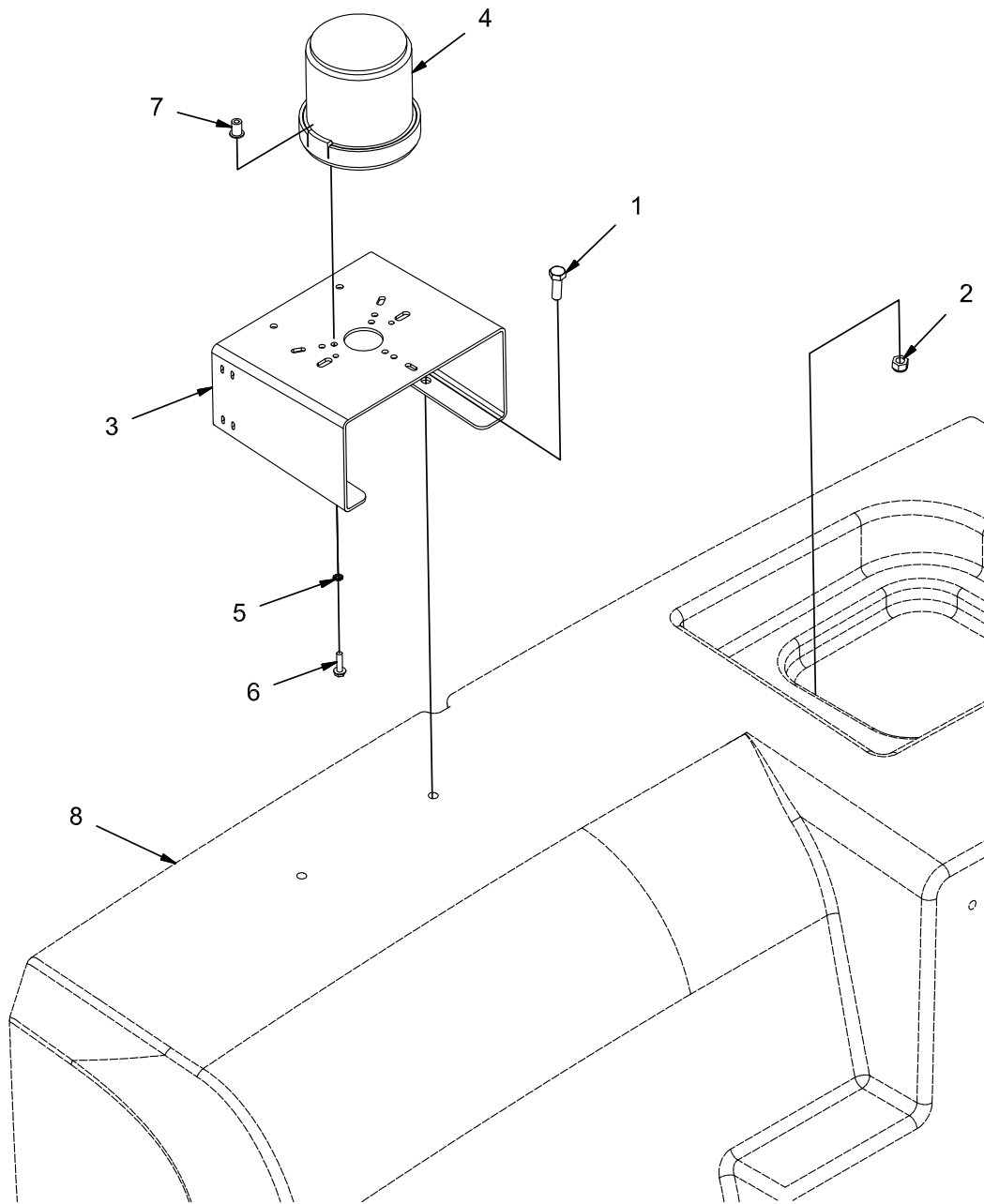

REV B

OPTION - FLASHING LIGHT GROUP (ON SOLUTION TANK) (730014)

Parts List 730014			
ITEM	PART NUMBER	QTY	DESCRIPTION
1	11039567	2	BOLT, M8-1.25 X 25 HH SS
2	12040259	2	NUT, M8-1.25 ESN SS
3	731030	1	MOUNT, SAFETY LIGHTS
4	748920	1	ASSEMBLY, AMBER FLASHING LIGHT
5	PART OF 748920	2	STAR WASHER
6	PART OF 748920	2	SCREW
7	PART OF 748920	2	NUT, EXPANSION
8	REF.	-	SOLUTION TANK
	748980	1	HARNESS, SAFETY LIGHT & BACKUP ALARM

OPTION - CHEMICAL METERING GROUP (730015)

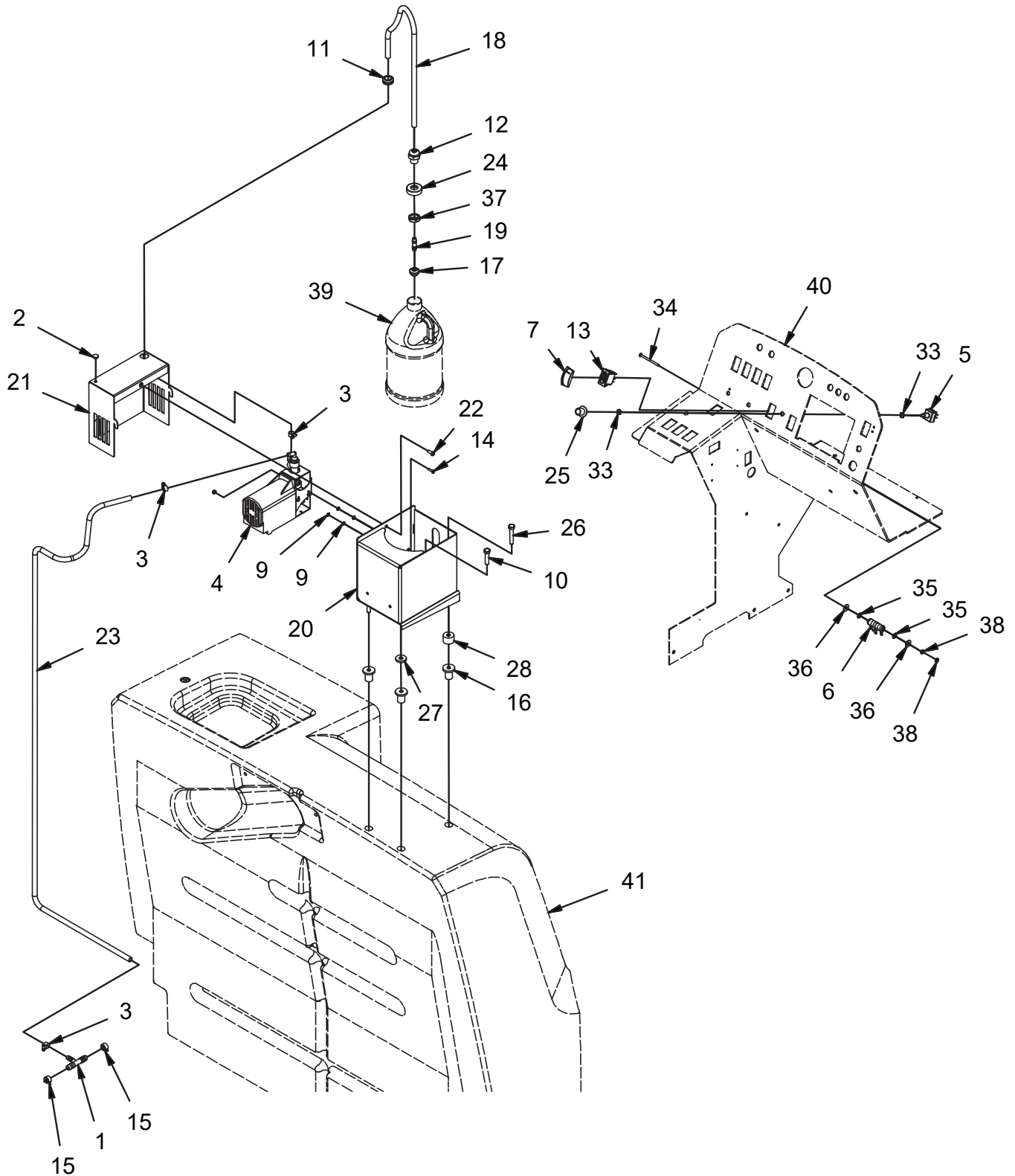

REV C

OPTION - CHEMICAL METERING GROUP (730015)

Parts List 730015			
ITEM	PART NUMBER	QTY	DESCRIPTION
1	172400	1	FITTING, TEE, .38 X .50 X .50 POLY
2	3300526	1	BUMPER, .25 ID .125 T
3	3302144	3	CLAMP, HOSE, .50 - 1.00
4	3303001	1	PUMP, METERING
5	3303072	1	SWITCH, ROTARY, 4-WAY
6	3323992	1	RESISTOR
7	3342273	1	SWITCH COVER - BLACK, CLEAR
8	3400082	2	NUT, FIBER INSERT #8-32
9	3400096	4	FLATWASHER, #8
10	3400455	2	SCREW, 3/8-16 X 1.50 HH SS
11	600151	1	GROMMET, .63 ID .88 OD .25 T
12	600482	1	STRAIN RELIEF
13	620137	1	SWITCH BODY, DPST W/GREEN L
14	710230	2	SCREW, #8-32 X .62 PAN HD
15	730962	2	CLAMP, WIRE HOSE
16	730991	3	NUT, RUBBER EXPANSION
17	731105	1	STAINER, SUCTION, 40 MESH
18	731106	1	TUBING, .375 ID X .06 WALL VINYL
19	731107	1	FITTING, .38 HOSE BARB COUPLII
20	731111	1	WELDMENT, CHEMICAL PUMP MN
21	731114-1	1	ASSEMBLY, PUMP COVER
22	731116	1	SCREW, M6-1.00 X 16 BUTTON HC
23	731117	1	TUBING, .375 ID X .06 WALL VINYL
24	731119	1	CAP, CHEMICAL CONTAINER
25	731187	1	KNOB
26	731213	1	BOLT, 3/8-16 X 2.00 HH SS
27	731385	1	SPACER, .406 B 1.125 OD .188 T
28	731386	1	SPACER, .406 B 1.125 OD .750 T
29	748461	1	HARNESS ASSY, SPRAY PUMP
30	748462	1	HARNESS ASSY, SPRAY PUMP
31	748463	1	HARNESS ASSY, SPRAY PUMP
32	748464	1	WIRE ASSY
33	PART OF 3303072	2	NUT
34	PART OF 3323983	1	SCREW, #10-32 X 2.63
35	PART OF 3323983	2	WASHER, RIDGE
36	PART OF 3323983	2	FLAT WASHER, .31
37	PART OF 600482	1	NUT, PLASTIC
38	PART OF 3323983	2	NUT, #19-32
39	REF.	-	CHEMICAL CONTAINER
40	REF.	-	CONSOLE
41	REF.	-	SOLUTION TANK

OPTION - FIRE EXTINGUISHER GROUP (730016)

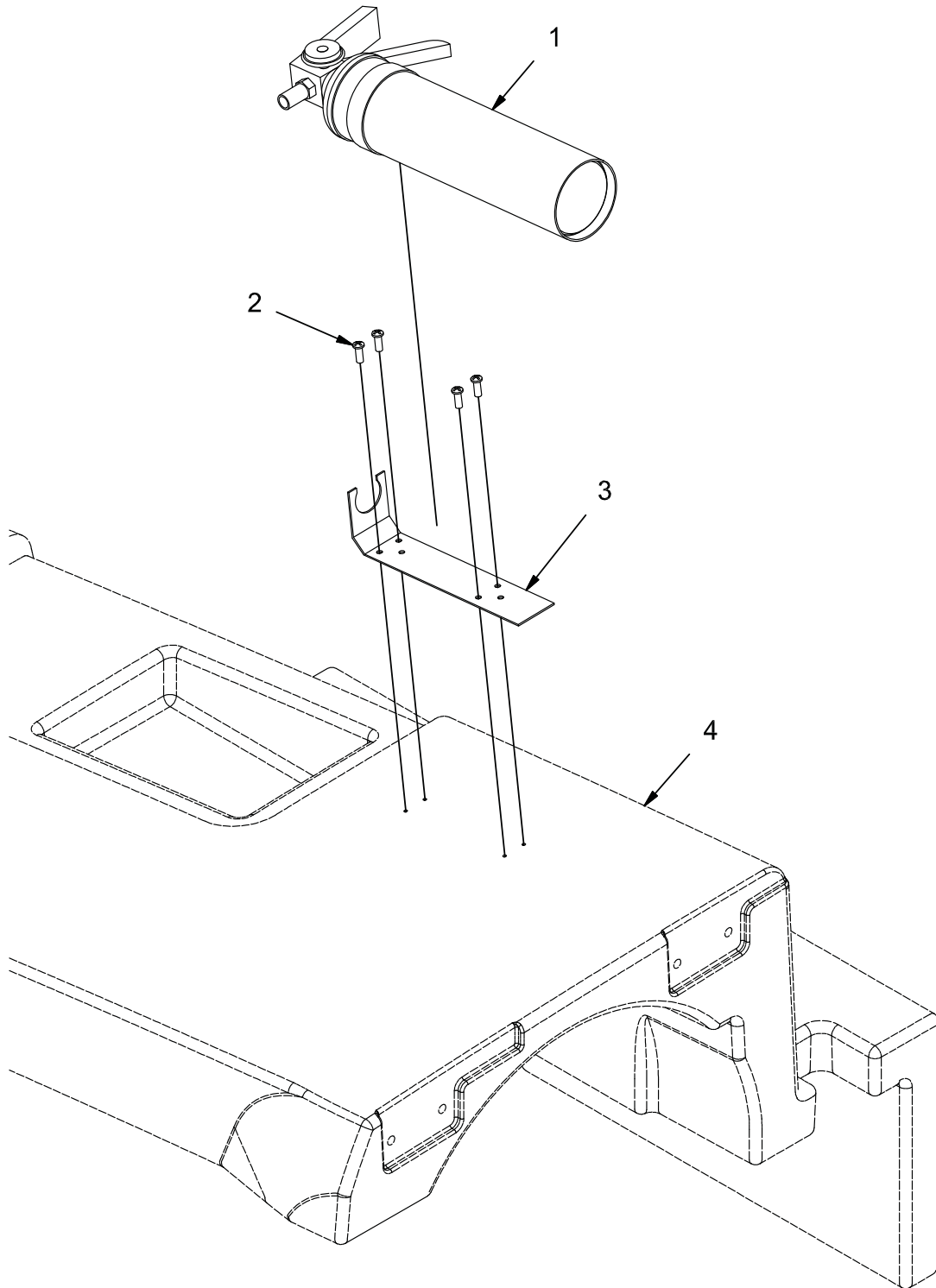

REV *

OPTION - FIRE EXTINGUISHER GROUP (730016)

Parts List 730016			
ITEM	PART NUMBER	QTY	DESCRIPTION
1	3302769	1	FIRE EXTINGUISHER
2	731099	4	SCREW, M6 X 16 PAN HD ZP FOR PLASTIC
3	PART OF 3302769	1	MOUNT, EXTINGUISHER
4	REF.	-	TOP COVER

OPTION - AUTO FILL GROUP (730017)

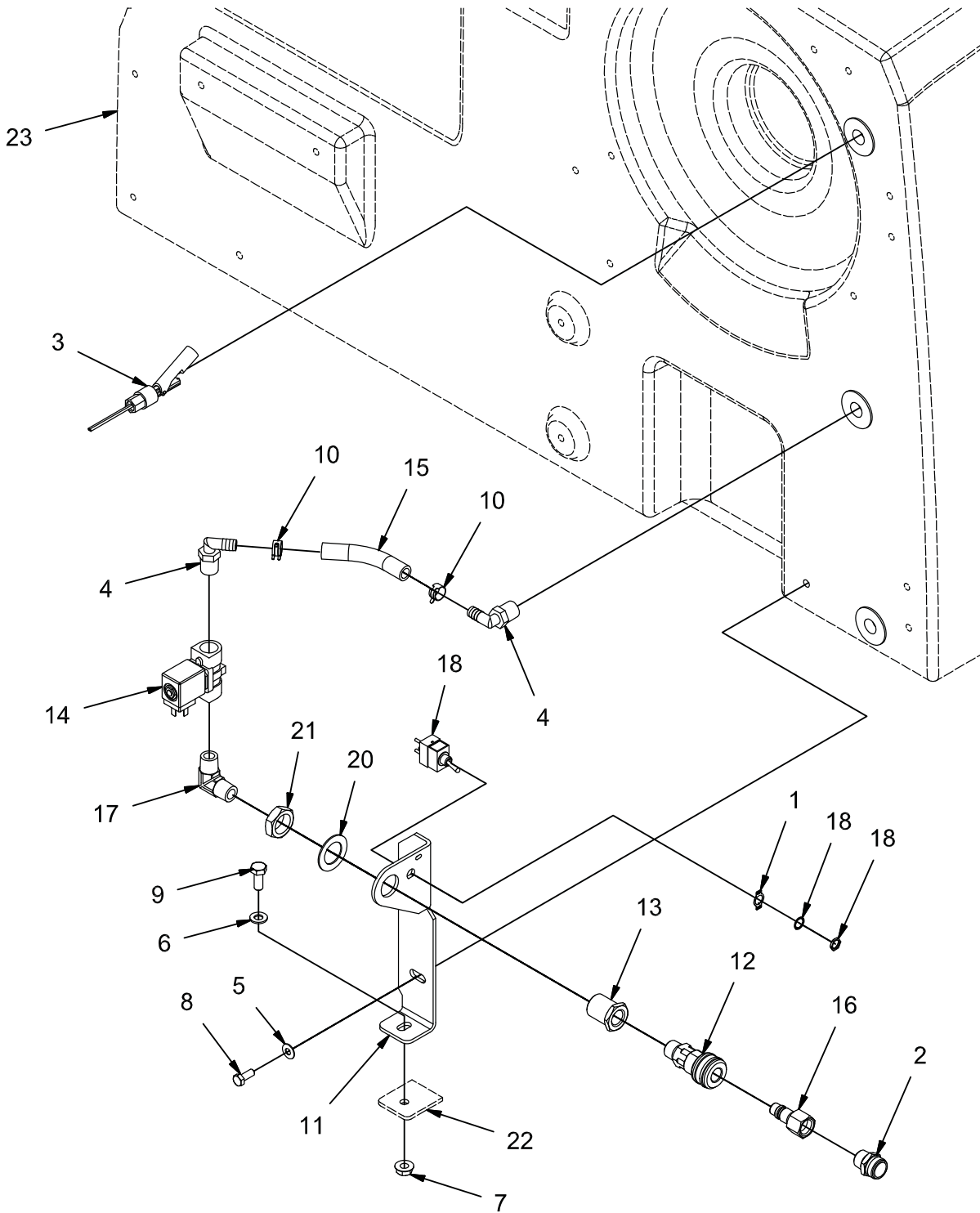

REV A

OPTION - AUTO FILL GROUP (730017)

Parts List 730017			
ITEM	PART NUMBER	QTY	DESCRIPTION
1	101020	1	INDICATOR PLATE
2	281426	1	FITTING, MALE GARDEN HOSE
3	3302737-1	1	WIRE ASSY, SWITCH, FLOAT
4	3315535	2	FITTING, PLASTIC, 90, .50 NPT .50 BARB
5	3400384	1	WASHER, 5/16 BELLEVILLE
6	3400385	1	WASHER, 3/8, BELLEVILLE
7	600936	1	NUT, M10-1.50 FLNG
8	717030	1	BOLT, M8-1.25 X 20 HH SS
9	730958	1	BOLT, M10-1.50 X 25 HH SS
10	730962	2	CLAMP, WIRE HOSE
11	731042	1	BRACKET, AUTO FILL
12	731043	1	COUPLER, QUICK DISCONNECT
13	731044	1	FITTING, BULKHEAD COUPLING
14	731045	1	VALVE, SOLENOID WATER
15	731046	1	TUBING, .50 ID, VINYL
16	731048	1	FITTING, QUICK DISCONNECT NIPPLE
17	731049	1	FITTING, ELBOW
18	747693-1	1	SWITCH ASM, TOGGLE, SPDT
19	748989	1	HARNESS, AUTO FILL
20	PART OF 731044	1	WASHER
21	PART OF 731044	1	NUT
22	REF.	-	FRAME
23	REF.	-	SOLUTION TANK

OPTION - SPRAY AND VAC WAND TOOL GROUP (730020)

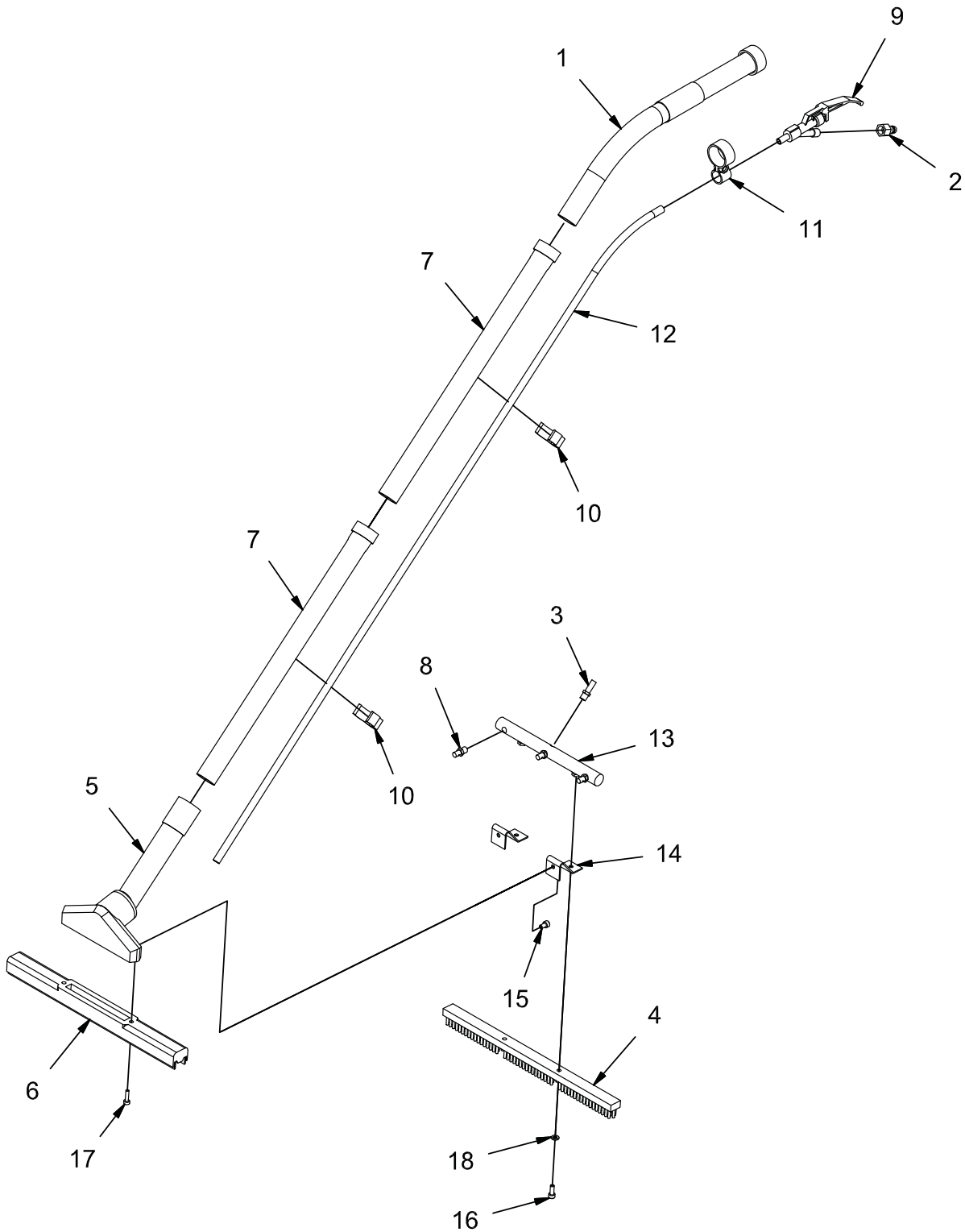

REV *

OPTION - SPRAY AND VAC WAND TOOL GROUP (730020)

Parts List 730020			
ITEM	PART NUMBER	QTY	DESCRIPTION
1	-	1	UPPER TUBE - AVAILABLE ON REQUEST
2	00054440	1	FITTING, MALE QUICK DISCONNECT
3	00054450	1	FITTING, HOSE BARB
4	00112340	1	BRUSH STRIP
5	00112350	1	NOZZLE BODY
6	00112360	1	SQUEEGEE BLADE
7	00442330	2	TUBE
8	00501580	3	SPRAY NOZZLE
9	00552250	1	VALVE
10	00552410	2	CLIP, HOSE
11	00552440	1	BRACKET, PIPE
12	00704720	1	HOSE, SOLUTION
13	00704730	1	BLAST PIPE
14	03500300	2	BRACKET, RETAINER
15	11126018	2	BOLT, M6 X 10 AHCS
16	11126166	2	SCREW, CYL HD, M6 X 16
17	11405040	2	SCREW, SELF TAPPING 4,8 X 19
18	12310033	2	WASHER, M6
-	99700900	1	COMPLETE WAND

**GROUP (730030) - OPTION SPRAY AND VAC WAND, INCLUDES SUB-GROUPS:
730020, 730021, 730022, 730023.**

OPTION - SPRAY AND VAC WAND HOSE GROUP (730021)

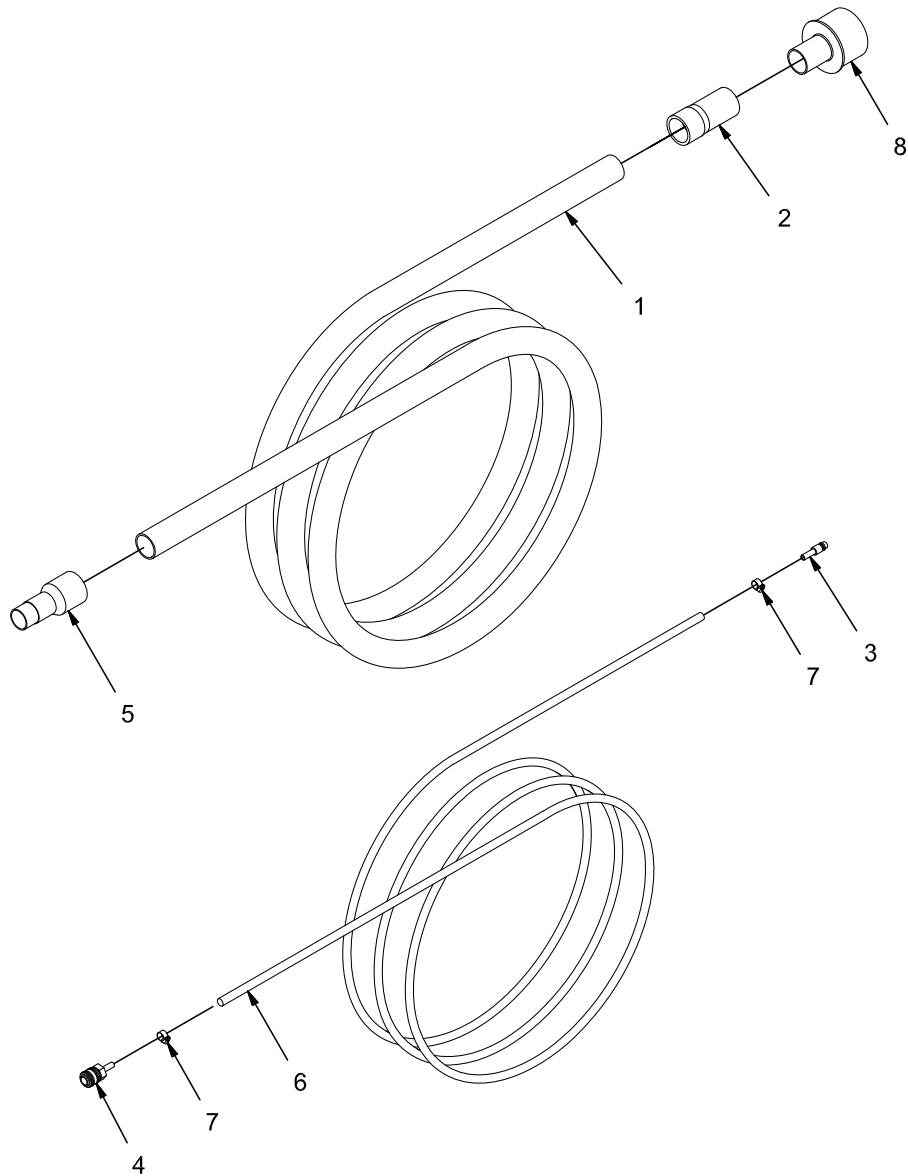

REV *

OPTION - SPRAY AND VAC WAND HOSE GROUP (730021)

Parts List 730021			
ITEM	PART NUMBER	QTY	DESCRIPTION
1	00010670	1	ASSEMBLY, VACUUM HOSE
2	00101280	1	HOSE CUFF. FEMALE
3	00552380	1	MALE QUICK DISCONNECT
4	00552400	1	FEMALE QUICK DISCONNECT
5	00782240	1	HOSE CUFF, MALE
6	01074690	1	ASSEMBLY, PRESSURE HOSE
7	17533100	2	CLAMP, HOSE
8	731098	1	ADAPTER, HOSE
-	99776600	1	COMPLETE KIT LESS 731098 ADAPTER

**GROUP (730030) - OPTION SPRAY AND VAC WAND, INCLUDES SUB-GROUPS:
730020, 730021, 730022, 730023.**

OPTION - SPRAY AND VAC WAND MOUNT GROUP (730022)

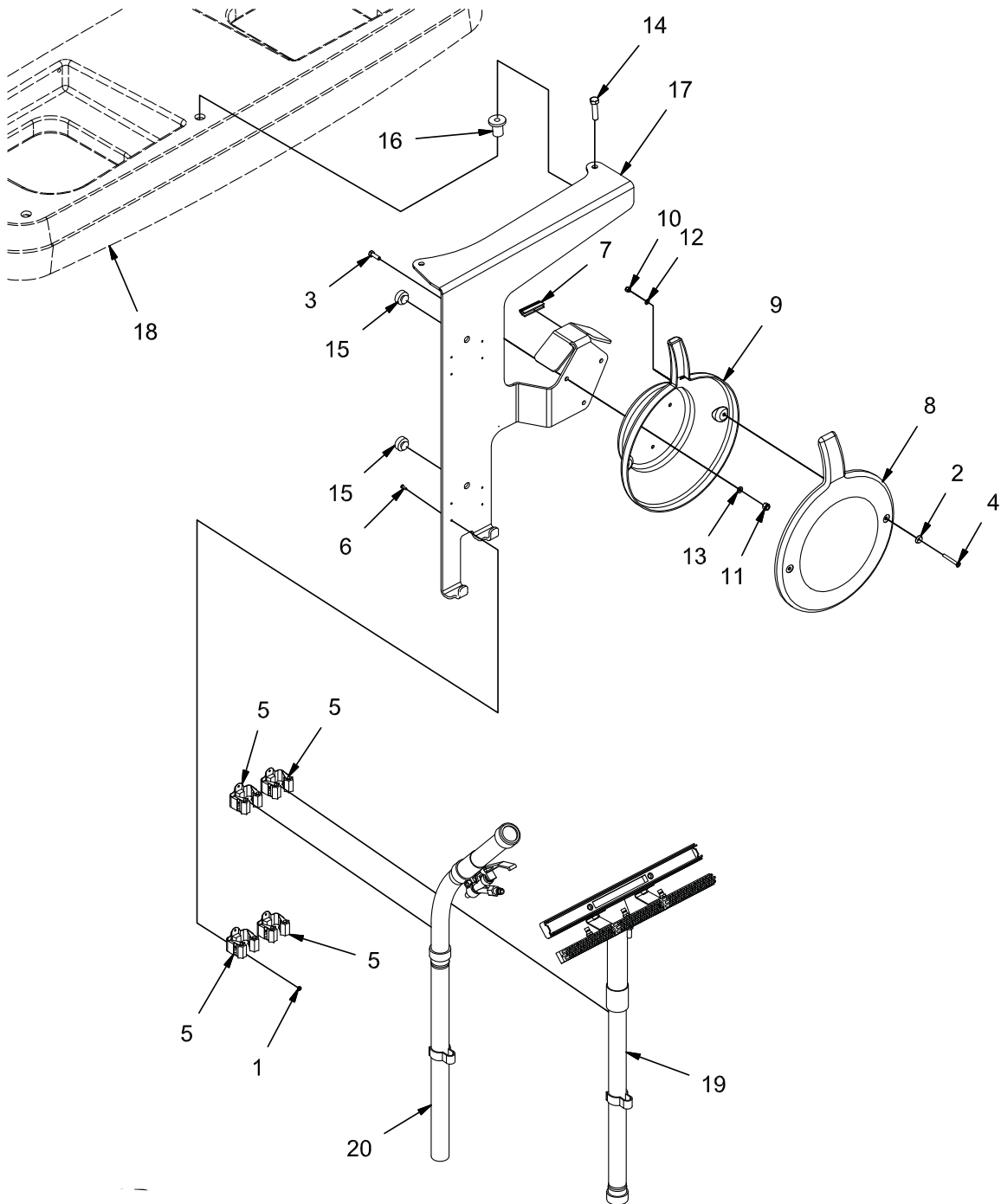

REV B

OPTION - SPRAY AND VAC WAND MOUNT GROUP (730022)

Parts List 730022			
ITEM	PART NUMBER	QTY	DESCRIPTION
1	00022200	8	NUT, ESN
2	00076210	2	WASHER, DECORATIVE
3	00154070	3	BOLT, M6
4	00523440	2	SCREW, FLAT HD
5	00560010	4	CLAMP
6	00695680	8	SCREW, PHILLIPS
7	00800100	1	EDGING
8	01090890	1	HOSE MOUNT, COVER
9	01090900	1	HOSE MOUNT, HALF SHELL
10	12040036	2	NUT, M5 - 0.8 ESN
11	12040044	3	NUT, M6-1.00 ESN
12	12310025	2	WASHER, M5
13	12310033	6	WASHER, M6
14	3400455	2	SCREW, 3/8-16 X 1.50 HH SS
15	600117	2	BUMPER, 1.00 X .339 T
16	730991	2	NUT, RUBBER EXPANSION
17	731097	1	BRACKET, HOSE MOUNT
18	REF.	-	DEMISTER
19	REF.	-	LOWER VAC WAND ASSEMBLY
20	REF.	-	UPPER VAC WAND ASSEMBLY

**GROUP (730030) - OPTION SPRAY AND VAC WAND, INCLUDES SUB-GROUPS:
730020, 730021, 730022, 730023.**

OPTION - SPRAY AND VAC WAND PUMP GROUP (730023)

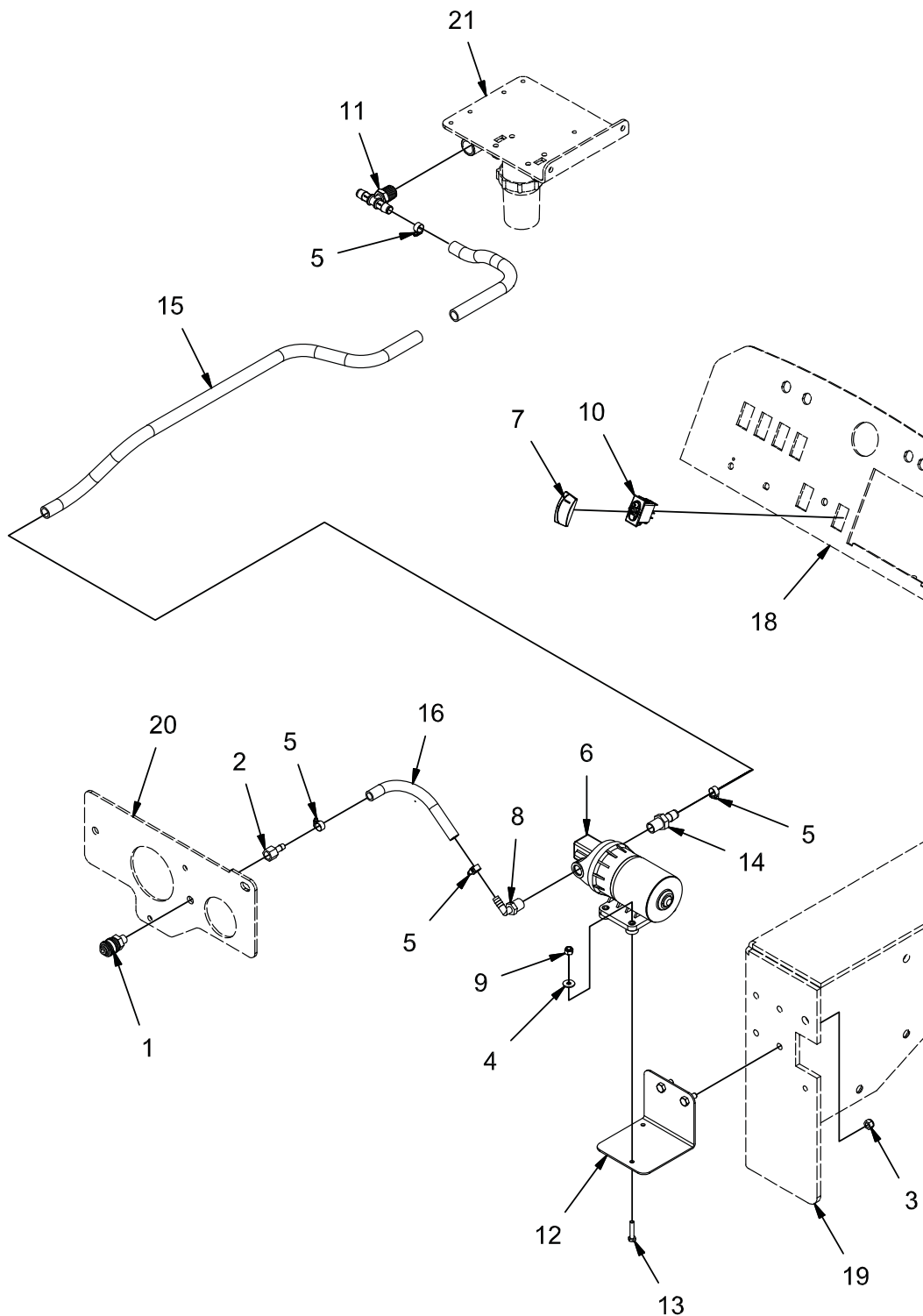

REV A

OPTION - SPRAY AND VAC WAND PUMP GROUP (730023)

Parts List 730023			
ITEM	PART NUMBER	QTY	DESCRIPTION
1	00552590	1	FEMALE QUICK DISCONNECT
2	00552600	1	FITTING, BARB
3	12040259	2	NUT, M8-1.25 ESN SS
4	12332011	2	WASHER, FENDER, M6
5	3302338	4	CLAMP, HOSE, .50
6	3331278	1	PUMP, SOLUTION
7	3342273	1	SWITCH COVER - BLACK, CLEAR LENS
8	3400985	1	FITTING, PLASTIC, 90, .375 NPT .375 BARB
9	600933	2	NUT, M6-1.00 ESN SS
10	620137	1	SWITCH BODY, DPST W/GREEN LAMP
11	730969	1	FITTING, TEE, .50 NPT - .50 BARB, NYLON
12	731038	1	WELDMENT, PUMP MNT
13	731050	2	BOLT, M6-100 X 30 HH SS
14	731094	1	FITTING, STR, 1/2 BARB X 3/8 MALE NPT
15	731095	1	TUBING, .50 ID VINYL
16	731096	1	TUBING, .375 ID VINYL
17	748797	1	HARNESS, OAW PUMP OPT
18	REF.	-	INST PANEL
19	REF.	-	FRAME
20	REF.	-	VALVE MOUNT PLT
21	REF.	-	FILTER MNT BRACKET

**GROUP (730030) - OPTION SPRAY AND VAC WAND, INCLUDES SUB-GROUPS:
730020, 730021, 730022, 730023.**

OPTION - URETHANE SQUEEGEE BLADE GROUP (730024)

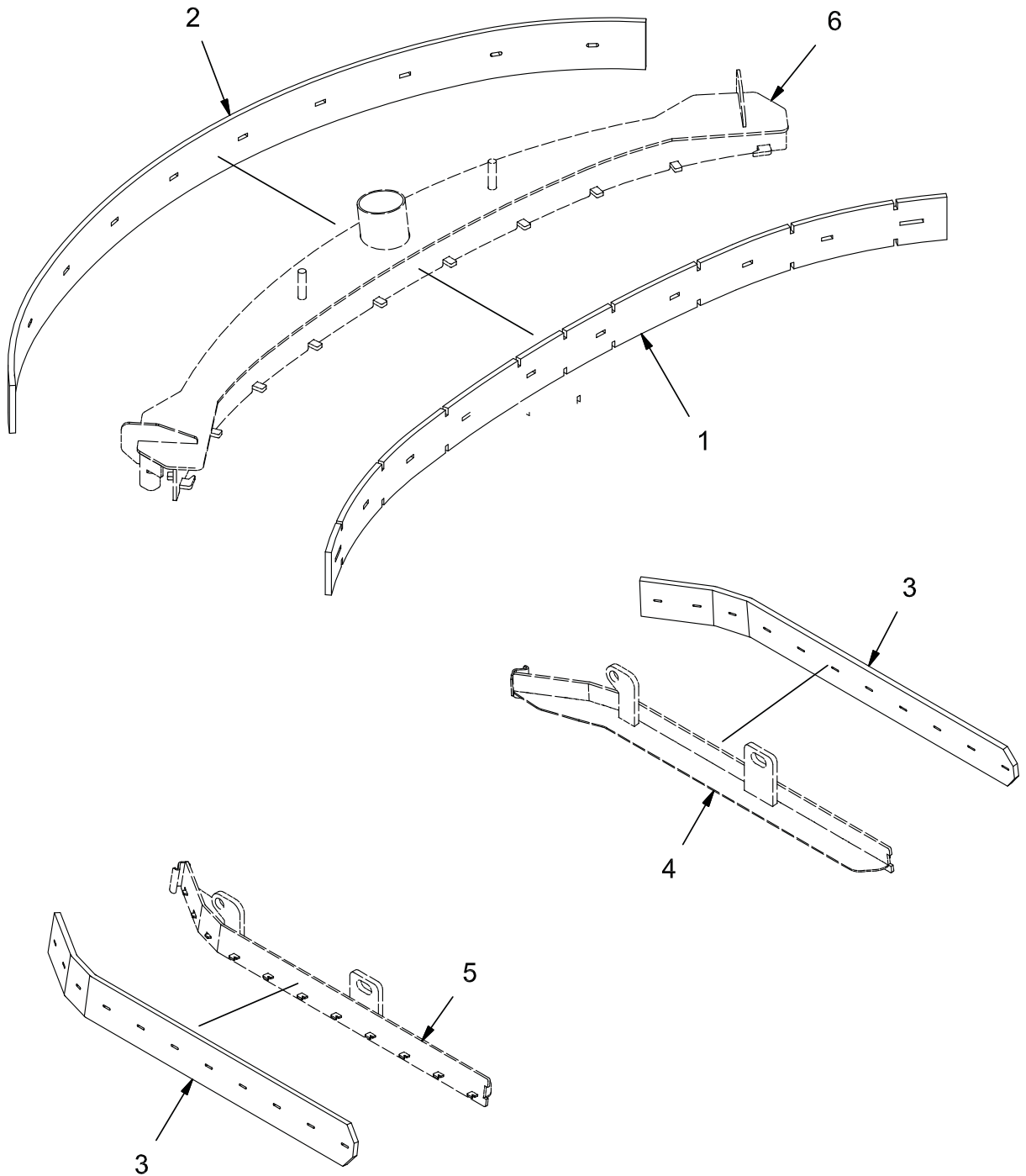

REV *

OPTION - URETHANE SQUEEGEE BLADE GROUP (730024)

Parts List 730024			
ITEM	PART NUMBER	QTY	DESCRIPTION
1	731101	1	SQUEEGEE BLADE, FRONT, URETHANE
2	731102	1	SQUEEGEE BLADE, REAR, URETHANE
3	731103	2	SQUEEGEE, SIDE, URETHANE
4	REF.	-	LH SQUEEGEE MOUNT
5	REF.	-	RH SQUEEGEE MOUNT
6	REF.	-	SQUEEGEE WELDMENT

OPTION - URETHANE SIDE BRUSH SQUEEGEE GROUP (730025)

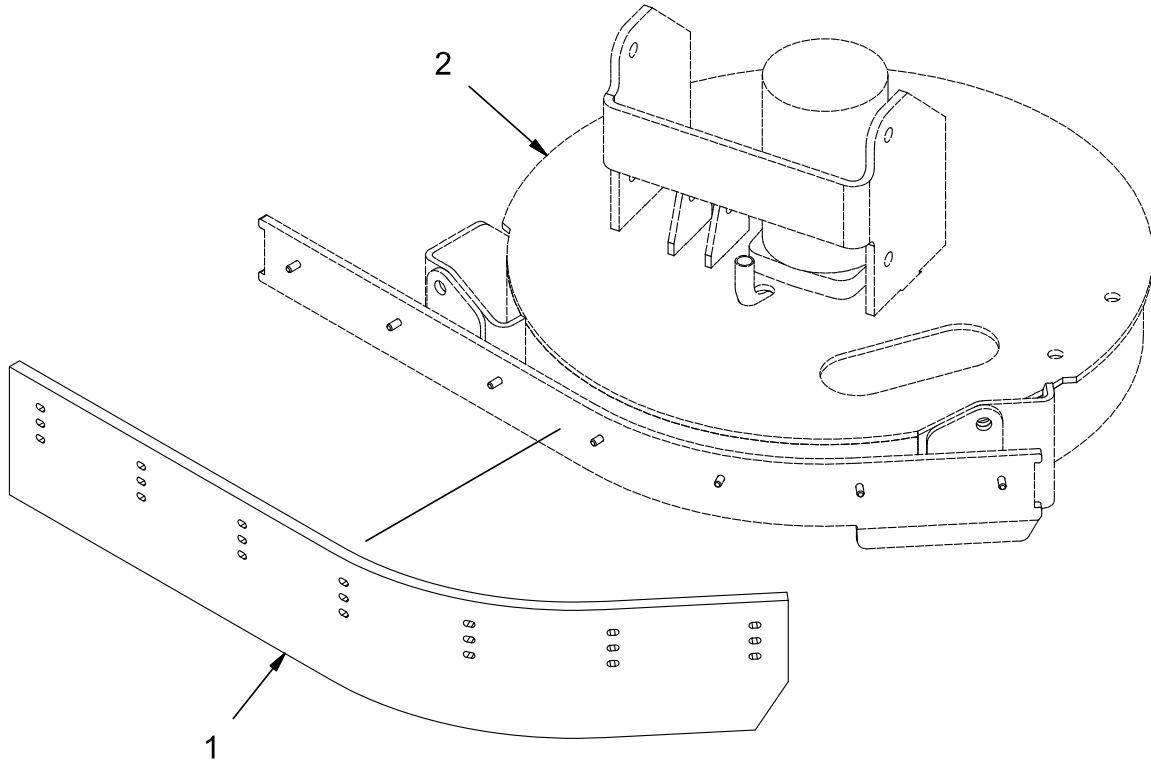

REV *

OPTION - URETHANE SIDE BRUSH SQUEEGEE GROUP (730025)

Parts List 730025			
ITEM	PART NUMBER	QTY	DESCRIPTION
1	731104	1	SSB SQUEEGEE BLADE, URETHANE
2	REF.	-	SSB MOUNT

OPTION - STAINLESS STEEL HOPPER GROUP (730027)

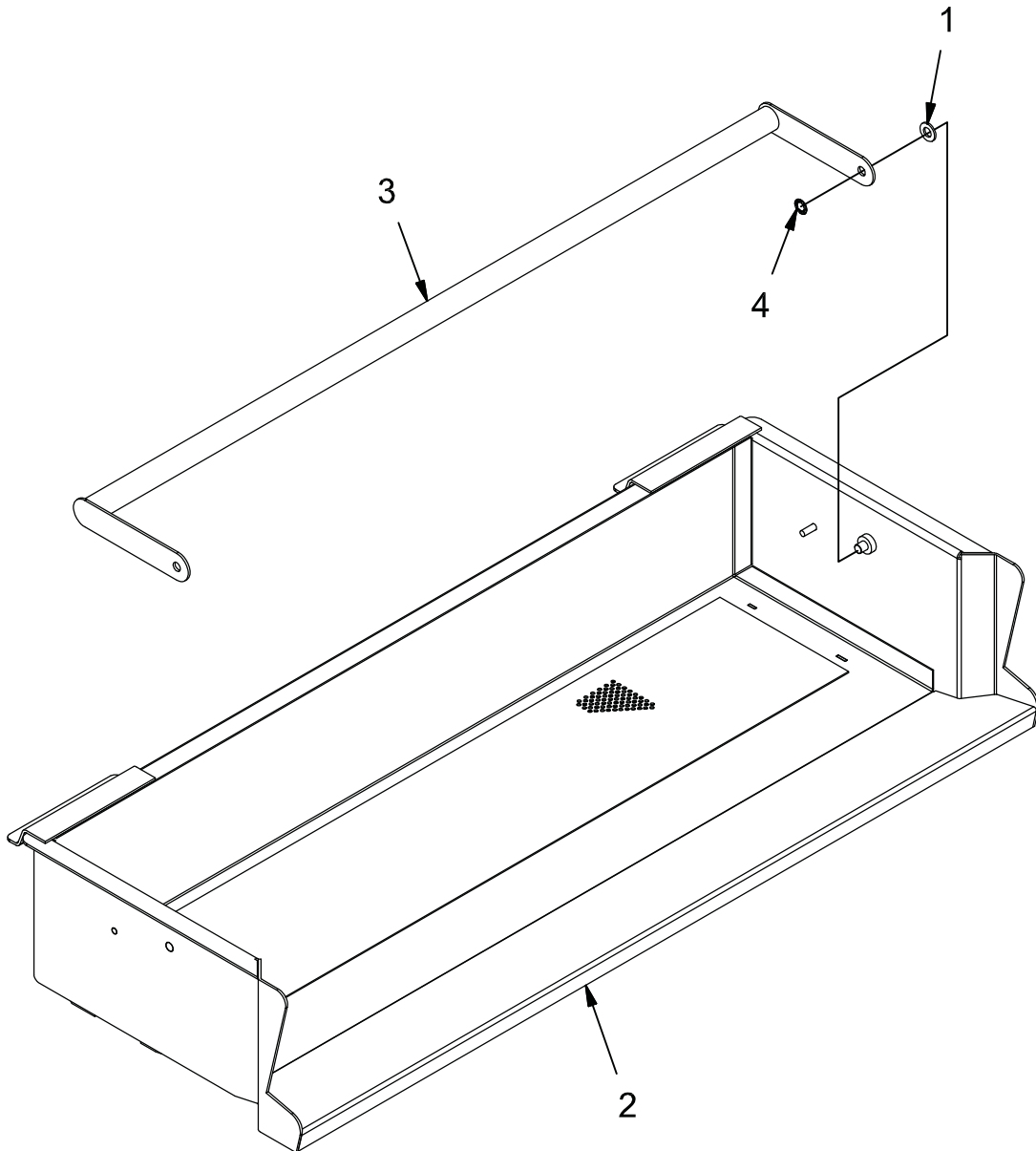

REV *

OPTION - STAINLESS STEEL HOPPER GROUP (730027)

Parts List 730124			
ITEM	PART NUMBER	QTY	DESCRIPTION
1	730344	2	WASHER, M10 SS
2	730815	1	WELDMENT, HOPPER
3	730835	1	WELDMENT, HANDLE
4	730844	2	RETAINING CLIP, .375 SS

OPTION - SEAT SWITCH (730031)

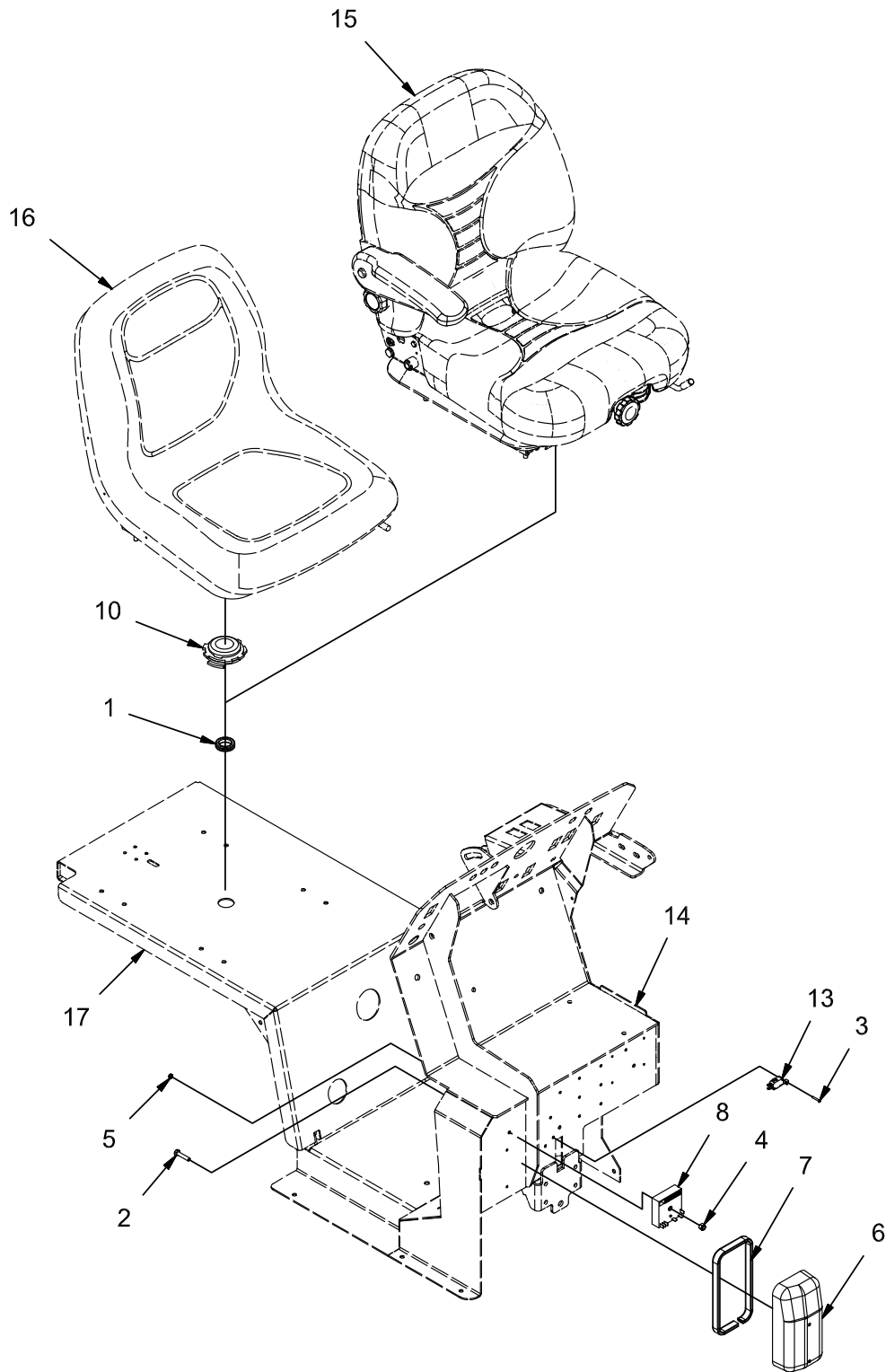

REV A

OPTION - SEAT SWITCH (730031)

Parts List 730031			
ITEM	PART NUMBER	QTY	DESCRIPTION
-	748456	1	HARNESS, SWITCH BYPASS
-	748444	1	STD SEAT SWITCH HARNESS
1	220327	1	GROMMET. 1.25 X 1.00 X .125
2	3400227	1	SCREW, 1/4-20 X 1.25 HH ZP
3	710493	2	SCR-MC RND HD 4-40 X .75 ZP
4	711373	1	NUT, FIBER INSERT 1/4-20
5	712348	2	NUT, HEX 4-40 NYLON LOCK, ZP
6	731275	1	COVER, TIMER/CONTROLLER
7	731276	1	SEAL, CONTROLLER
8	748430	1	TIMER
10	748445	1	SWITCH - N/O TWIST LOCK (USED WITH STANDARD SEAT ONLY)
12	748999	1	SEAT SWITCH HARNESS
13	90636234	1	MICRO-SWITCH
14	REF.	-	CONSOLE
15	REF.	-	OPTIONAL SUSPENSION SEAT
16	REF.	-	STANDARD SEAT
17	REF.	-	SEAT MNT

OPTION - SIDE BROOM GROUP (730032)

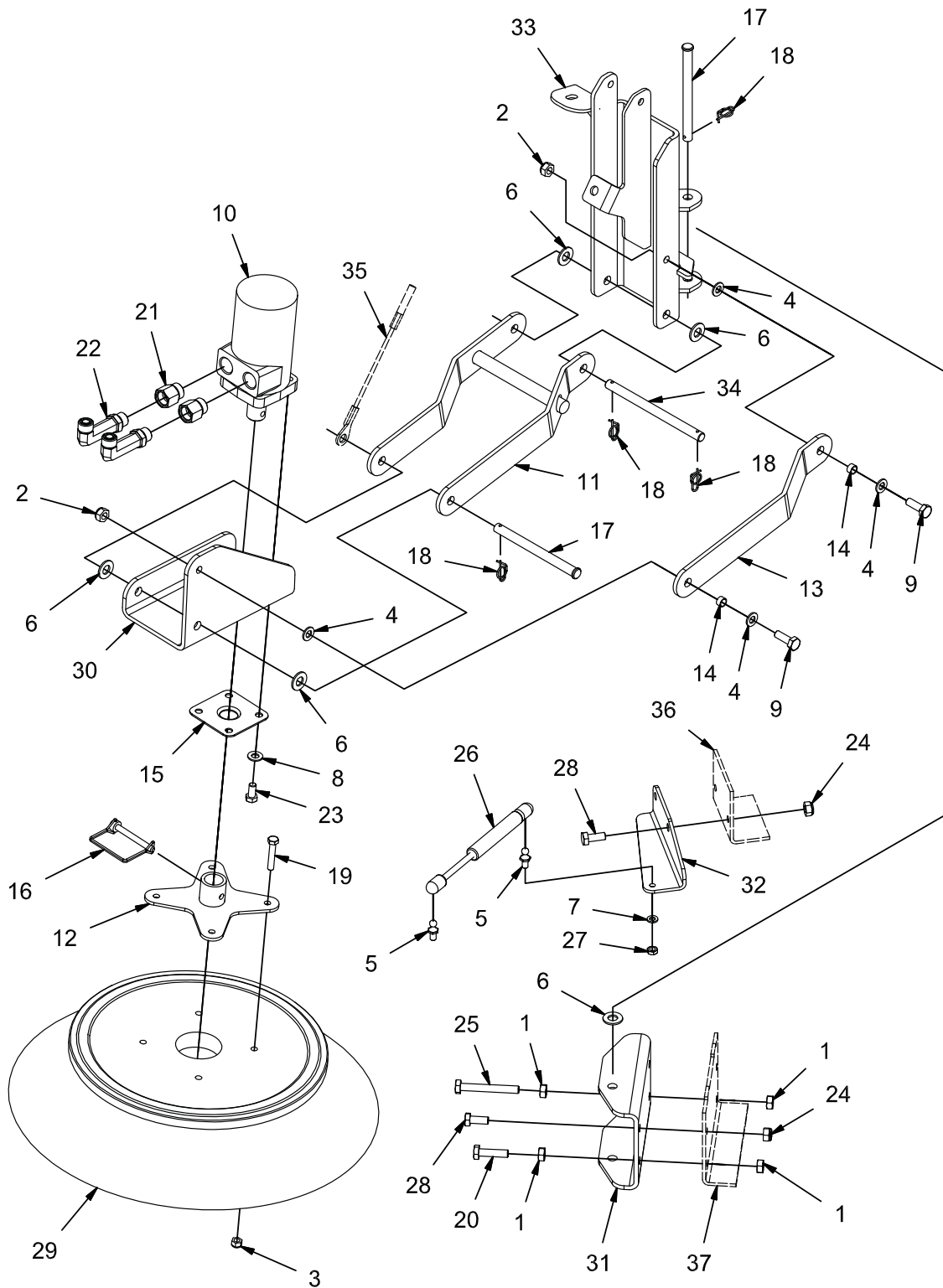

REV *

OPTION - SIDE BROOM GROUP (730032)

Parts List 730032			
ITEM	PART NUMBER	QTY	DESCRIPTION
1	12022067	4	NUT, M10-1.50 HEX
2	12040069	2	NUT, M10-1.50 ESN
3	12040259	4	NUT, M8-1.25 ESN SS
4	12310058	4	WASHER, M10
5	3300376	2	STUD, 10MM BALL
6	3400086	5	WASHER, 1/2, 1.063 X .531 X .094
7	3400102	2	LOCK WASHER, 5/16 HS MED
8	3400385	4	WASHER, 3/8, BELLEVILLE
9	3401051	2	BOLT, M10-1.50 X 30 HH
10	600217	1	MOTOR, 17.9 DISP
11	600303	1	WELDMENT, SB TRAILING ARM
12	600322	1	WELDMENT, SB FLANGE
13	600325	1	SB LINK
14	600327	2	SPACER, .406 B .50 OD .280 T
15	600330	1	STRING GUARD
16	600566	1	PIN, WIRE LOCK, .313
17	600571	2	PIN, CLEVIS 1/2 X 6.00
18	600578	4	RUE-RING, .50
19	600820	4	BOLT, M8-1.25 X 45 HH
20	600962	1	BOLT, M10-1.50 X 40 HH FULL THRD
21	3400166	2	FITTING, REDUCER -10 SAE -8 SAE
22	675606	2	FITTING, LONG ELBOW -8 ORFS -8 SAE
23	713041	4	SCREW, 3/8-16 X .750 HHC
24	730339	4	NUT, M10-1.50 ESN SS
25	730424	1	BOLT, M10-1.50 X 80 HH ALL-THRD
26	730902	1	GAS STRUT, 8.77 EXT, 3.00 STK, 200N
27	730904	2	NUT, 5/16-18 HEX JAM SS
28	730958	4	BOLT, M10-1.50 X 25 HH SS
29	731274	1	BROOM, SIDE, 20"
30	731278	1	MOUNT, SB MOTOR
31	731279	1	MOUNT, SB PIVOT
32	731280	1	MOUNT, SB GAS STRUT
33	731285	1	WELDMENT, SB PIVOT
34	731290	1	PIN, RETAINING
35	REF.	-	SB CABLE
36	REF.	-	FRAME
37	REF.	-	FRAME

**GROUP (730037) - OPTION SIDE BROOM, INCLUDES SUB-GROUPS:
730032, 730033, 730034, 730028, 730029**

OPTION - SIDE BROOM LIFT AND ADJUSTMENT GROUP (730033)

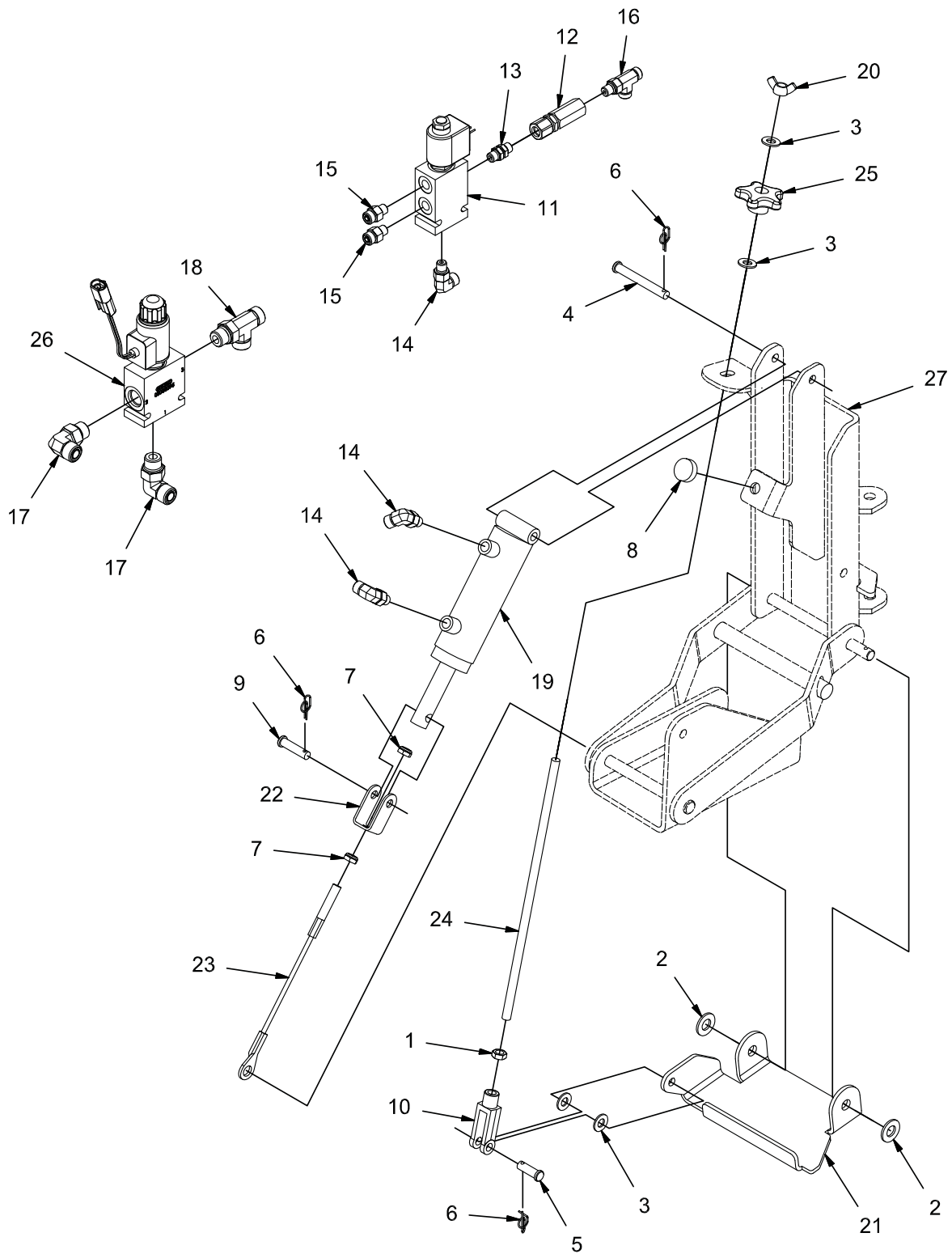

REV A

OPTION - SIDE BROOM LIFT AND ADJUSTMENT GROUP (730033)

Parts List 730033			
ITEM	PART NUMBER	QTY	DESCRIPTION
1	3400075	1	NUT, HEX JAM 3/8-24
2	3400086	6	WASHER, 1/2, 1.063 X .531 X .094
3	3400087	4	WASHER, 3/8
4	3400115	1	PIN, CLEVIS, .375 X 3.00
5	3400117	1	PIN, CLEVIS 3/8 X 1.125
6	3400125	3	RUE-RING, .375
7	3401028	2	NUT, FIBER INSERT 3/8-16 JAM
8	600117	1	BUMPER, 1.00 X .339 T
9	600573	1	PIN, CLEVIS, 3/8 X 1.50
10	600813	1	CLEVIS, 3/8-24
11	620005	1	SOLENOID, 2-POS, 4-WAY, CROSSOVER
12	620008	1	CHECK VALVE
13	620110	1	ADAPTER, #4 O-RING - #4 O-RING
14	675507	3	FITTING, 90, -4 ORFS - 4 SAE
15	675508	2	FITTING, STR, 4 ORFS - 4-SAE
16	675509	1	FITTING, RUN TEE -4 ORFS TO -4 SAE
17	675523	2	FITTING, 90, -8 ORFS - 8 SAE
18	675525	1	FITTING, RUN TEE, 8 ORFS - 8 ORFS - 8 SAE
19	730548	1	CYLINDER, HYD, 1.50 B X 2.88 STK
20	731277	1	WING NUT, 3/8-24, NYLON
21	731281	1	CHANNEL, SB ADJUSTMENT
22	731282	1	CLEVIS, CABLE
23	731283	1	SB CABLE
24	731284	1	ROD, SB ADJUSTMENT
25	731291	1	KNOB, 3/8-24
26	731292	1	ASSEMBLY, SOLENOID VALVE 2-POS 3-WAY
27	REF.	-	PIVOT ASSEMBLY

**GROUP (730037) - OPTION SIDE BROOM, INCLUDES SUB-GROUPS:
730032, 730033, 730034, 730028, 730029**

OPTION - SIDE BROOM HYDRAULIC HOSE GROUP (730034)

NOTE:

THERE IS NO PICTURE AVAILABLE FOR THIS GROUP

REV *

OPTION - SIDE BROOM HYDRAULIC HOSE GROUP (730034)

PART NUMBER	QTY	DESCRIPTION
675470	2	HOSE CHRG T (STR) TO HOP OUT (90)
731075	1	HOSE,4 STR-4 90 MED (VALVE T1 TO RES)
731079	1	HOSE,8 STR-8 90 MED (LH MB TO SSB VALVE)
731081	1	HOSE,10 STR-8 45MED (VALVE T2 TO SSB VAL)
731084	1	HOSE,4 STR-4 STR MED (STR TEE TO SSB VAL)
731085	2	HOSE,4 STR-4 90 MED (VALVE T1 TO SSB VAL)
731068	1	HOSE, 4 STR - 4 45 STR MED (VALVE TO CYL)

**GROUP (730037) - OPTION SIDE BROOM, INCLUDES SUB-GROUPS:
730032, 730033, 730034, 730028, 730029**

OPTION - SIDE BRUSH HYDRAULIC HOSE ROUTING (730038)

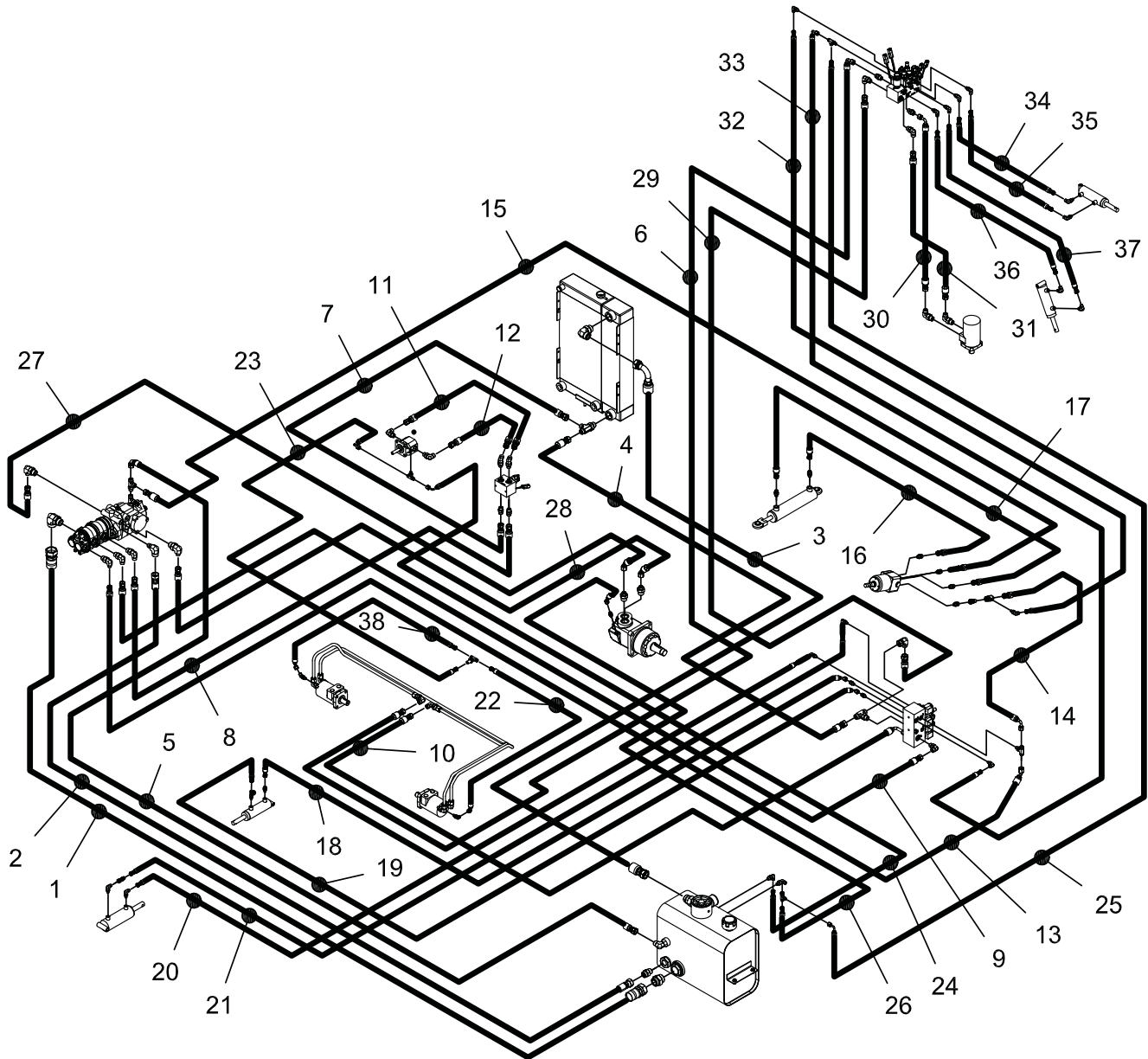

REV B

OPTION - SIDE BRUSH HYDRAULIC HOSE ROUTING (730038)

Parts List 730038			
ITEM	PART NUMBER	QTY	DESCRIPTION
1	731051	1	HOSE, 20 STR - 20 STR SUC (RES TO AUX PUMP IN)
2	731052	1	HOSE, 12 STR - 12 STR SUC (RES TO VDP CASE)
3	731053	1	HOSE, 16 STR - 16 90 RET (COOLER UPPER TO RES)
4	731054	1	HOSE, 10 STR - 10 STR RET (VALVE T2 TO COOLER)
5	731055	1	HOSE, 10 STR - 8 90 RET (VDP CASE TO RES)
6	731079	1	HOSE, 8 STR - 8 90 MED (LH MB TO SSB VALVE P2)
7	731057	1	HOSE, 8 STR - 10 STR MED (IMP SOL T TO COOLER)
8	731058	1	HOSE, 8 STR - 8 STR MED (AUX PUMP 1 TO IMP SOL P)
9	731059	1	HOSE, 8 STR - 8 STR MED (AUX PUMP 2 TO VALVE P2)
10	731060	1	HOSE, 8 STR - 8 90 MED (VALVE MB OUT TO MB RIGHT)
11	731061	1	HOSE, 8 STR - 8 90 MED (IMP SOL VF OUT TO IMP LEFT)
12	731062	1	HOSE, 8 STR - 8 90 MED (IMP RIGHT TO IMP SOL VF IN)
13	731063	1	HOSE, 6 STR - 6 90 MED (AUX PUMP 3 TO VALVE P1)
14	731064	1	HOSE, 6 STR - 6 90 MED (VALVE P1 TO STR PRESS)
15	731065	1	HOSE, 6 STR - 8 STR RET (STR TANK TO VDP CASE)
16	731066	1	HOSE, 6 STR - 6 STR MED (STR LEFT TO CYL F)
17	731067	1	HOSE, 6 STR - 6 STR MED (STR RIGHT TO CYL R)
18	731068	1	HOSE, 4 STR - 4 45 MED (VALVE BL A TO SH CYL F)
19	731069	1	HOSE, 4 STR - 4 45 MED (VALVE BL A TO SH CYL R)
20	731070	1	HOSE, 4 STR - 4 STR MED (VALVE SG B TO SQU CYL F)
21	731071	1	HOSE, 4 STR - 4 STR MED (VALVE SG A TO SQU CYL R)
22	731072	1	HOSE, 4 STR - 4 45 MED (RH MB CASE TO SCRUB HEAD TEE)
23	731073	1	HOSE, 4 STR - 4 90 MED (SCRUB HD TO IMP CASE)
24	731074	1	HOSE, 4 STR - 4 90 MED (IMP CASE TO RES)
25	731075	1	HOSE, 4 STR - 4 90 MED (SSB VALVE T1 TO RES)
26	731076	1	HOSE, 4 STR - 4 45 MED (WHEEL DRIVE CASE TO RES)
27	731077	1	HOSE, 8 STR - 8 45 SPCL (VDP L TO WHEEL DRIVE R)
28	731078	1	HOSE, 8 STR - 8 45 SPCL (VDP R TO WHEEL DRIVE F)
29	731081	1	HOSE, 10 STR - 8 45 MED (VALVE T2 TO SSB VALVE T2)
30	731082	1	HOSE, 8 STR - 8 90 MED (SSB VALVE SB OUT TO SB R)
31	731083	1	HOSE, 8-STR - 8 STR MED (SSB VALVE SB IN TO SB F)
32	731084	1	HOSE, 4-STR - 4 STR MED (STR TEE TO SSB VALVE P1)
33	731085	1	HOSE, 4 STR - 4 90 MED (VALVE T1 TO SSB VALVE T1)
34	731089	1	HOSE, 4 STR - 4 STR MED (SSB VALVE SBE A TO EXT CYL L)
35	731087	1	HOSE, 4 STR - 4 STR MED (SSB VALVE SBE B TO EXT CYL R)
36	731088	1	HOSE, 4 STR - 4 STR MED (SSB VALVE SBL A TO LIFT CYL U)
37	731089	1	HOSE, 4 STR - 4 STR MED (SSB VALVE SBL B TO LIFT CYL L)
38	731168	1	HOSE, 4 STR - 4 45 MED (LH MB CASE TO SCRUB HEAD TEE)

OPTION - PRESSURE WASHER PUMP GROUP (730041-1)

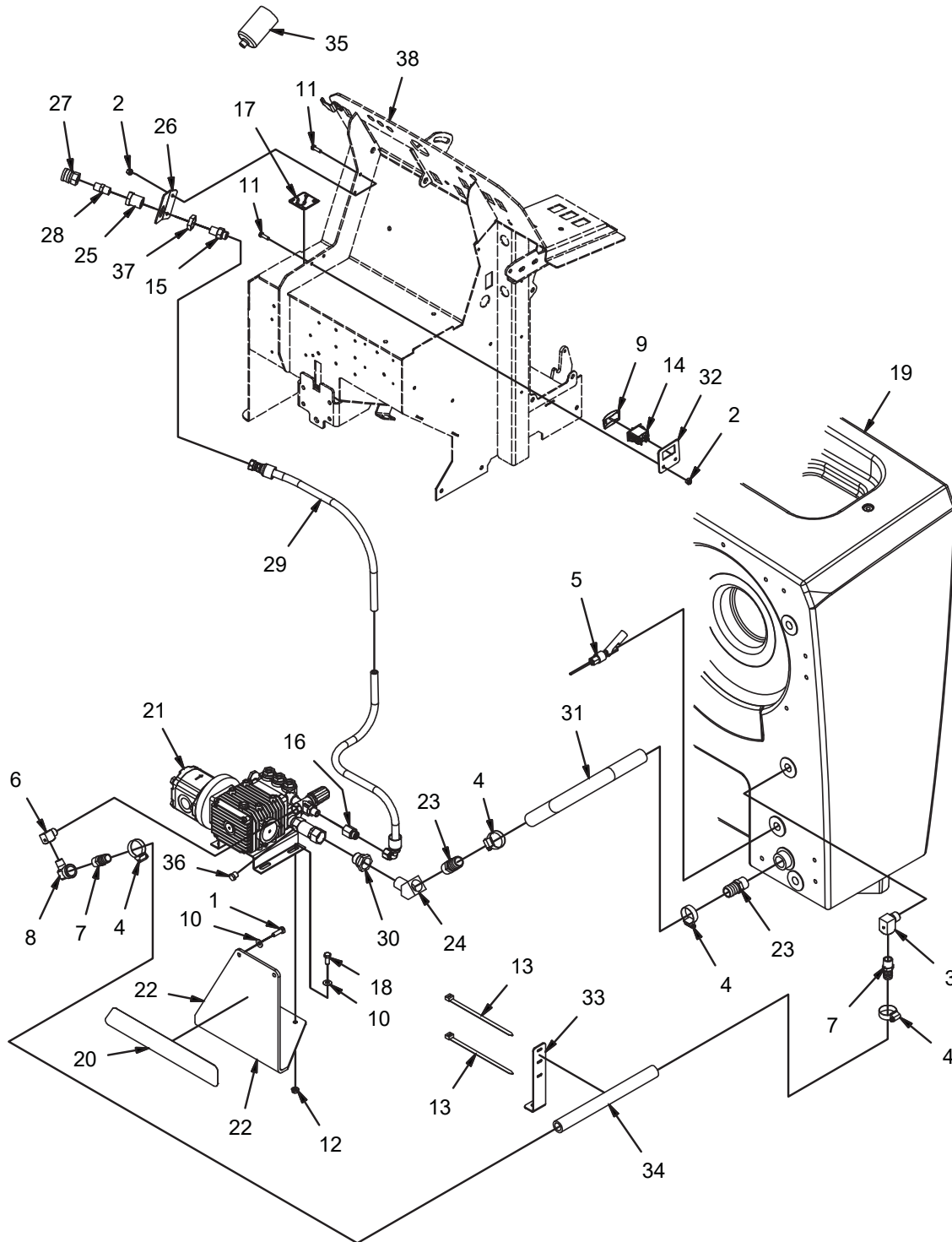

REV C

OPTION - PRESSURE WASHER PUMP GROUP (730041-1)

Parts List 730041-1			
ITEM	PART NUMBER	QTY	DESCRIPTION
1	11039567	2	BOLT, M8-1.25 X 25 HH SS
2	12040044	4	NUT, M6-1.00 ESN
3	281093	1	FTG, BRASS ELBOW, 1/2 MPT - 1/2 FPT
4	3302193	4	CLAMP, HOSE, .75 - 1.25
5	3302737-1	1	SWITCH, FLOAT
6	3320551	1	FTG, BRASS ELBOW, 3/8 MPT - 3/8 FPT
7	3320728	2	FTG, STR, 1/2 MPT 3/4 HOSE BARB
8	3339916	1	FTG, BRASS ELBOW, .38 FPT TO .50 MPT
9	3342273	1	SWITCH COVER - BLACK, CLEAR LENS
10	3400384	6	WASHER, 5/16 BELLEVILLE
11	600913	4	BOLT, M6-1.00 X 20 HH SS
12	600934	4	NUT, M8-1.25 FLNG
13	620037	2	NYLON CABLE TIE
14	620137	1	SWITCH BODY, DPST W/GREEN LAMP
15	675634	1	FITTING, STR, -6 MPT - 6 OFS SS
16	675635	1	FITTING, STR, -6 FPT - 6 OFS SS
17	715970	1	DECAL, WASH SWITCH
18	717030	4	BOLT, M8-1.25 X 20 HH SS
19	731463	1	TANK, SOL, PRESS WASHER - STD MACHINE
19	770597	1	TANK HD, SOL. PRESS WASHER - HIGH DUMP MACH
20	730967	1	PAD, STEP
21	731421	1	ASSEMBLY, PRESSURE WASHER (SEE BELOW)
22	731422	1	MOUNT, PRESSURE WASHER
23	731423	2	FTG, STR, 3/4 MPT 1 HOSE BARB
24	731424	1	FTG, BRASS, 45 STREET ELBOW, 3/4 NPT
25	731425	1	ANCHOR COUPLING 3/8 NPT
26	731436	1	MOUNT, QUICK DISCONNECT
27	731441	1	QUICK DISCONNECT, COUPLER W/VALVING
28	731449	1	FTG, BRASS HEX NIPPLE, 3/8 NPT
29	731454	1	HOSE, -6 STR -6 90, SS END FITTINGS
30	731455	1	ADAPTER, BRASS MALE HOSE TO 3/4 FPT
31	731456	1	TUBING, 1.00 ID RENFORCED VINYL
32	731459	1	BRACKET, SWITCH
33	731460	1	BRACKET, CLAMP
34	731461	1	TUBING, .75 ID VINYL
35	747041	1	BOOT, IGNITION SWITCH
36	829619	1	PLUG, 1/4 MPT, BRASS
37	PART OF 731425	1	NUT
38	REF.	-	CONSOLE
-	748735	1	HARNESS ASSY, PRESSURE WASHER
-	3500118	1	EDGING, VINYL TRIM .125 X 12.00 (NOT SHOWN) USED ON GROUP 730145 ITEM #11 730404

**ORDER 731486 CHECK VALVE REPLACEMENT KIT FOR 731421 PRESSURE WASHER ASSEMBLY

OPTION - PRESSURE WASHER HOSE AND WAND GROUP (730041-2)

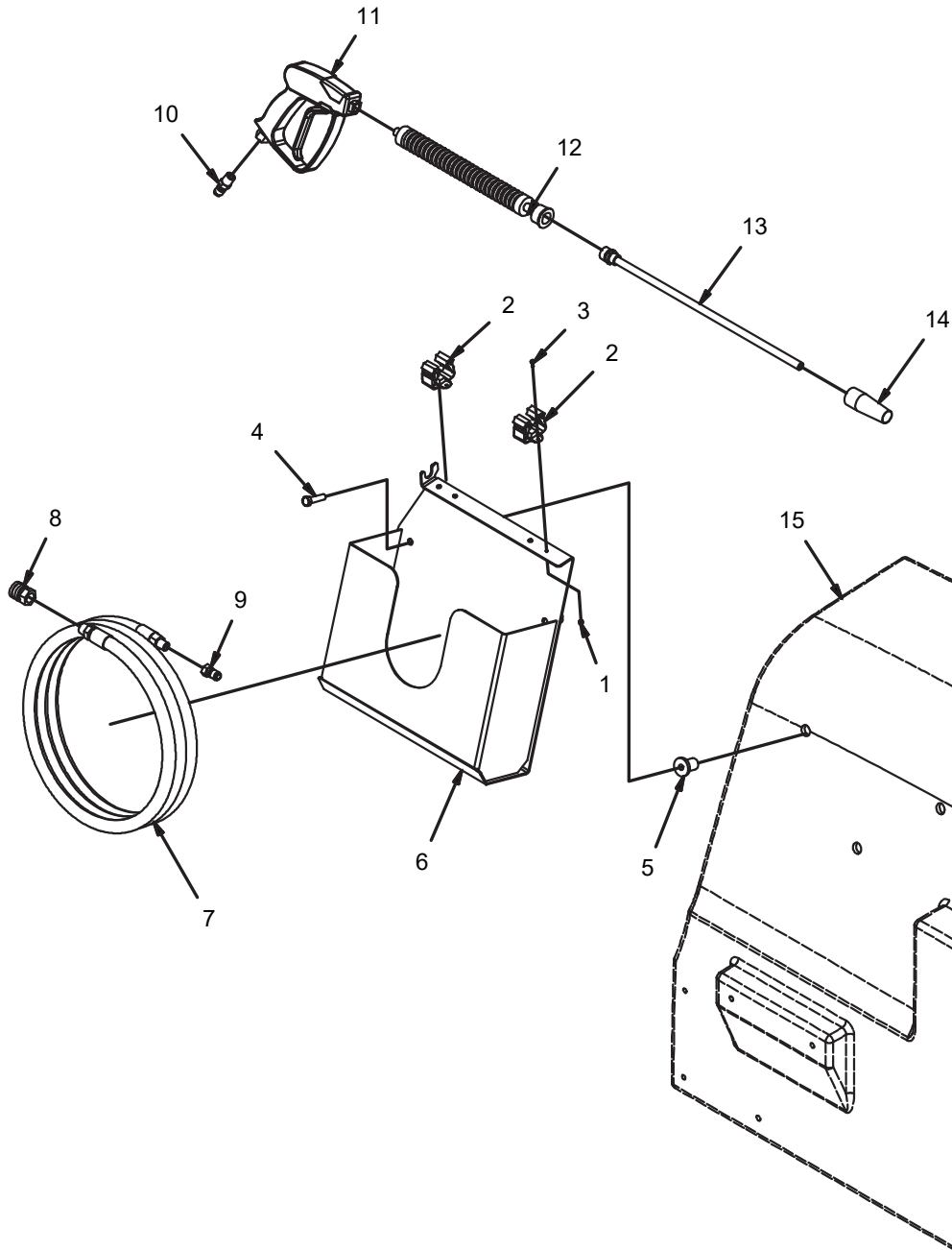

REV *

OPTION - PRESSURE WASHER HOSE AND WAND GROUP (730041-2)

Parts List 730041-2			
ITEM	PART NUMBER	QTY	DESCRIPTION
1	00022200	4	NUT, ESN
2	00560010	2	CLAMP
3	00695680	4	SCREW, PHILLIPS
4	3400455	3	SCREW, 3/8-16 X 1.50 HH SS
5	730991	3	NUT, RUBBER EXPANSION
6	731437	1	WELDMENT, HOSE BOX
7	731440	1	HOSE, PRESSURE WASHER 50 FT (PART OF KIT 731457)
8	731441	1	QUICK DISCONNECT, COUPLER (PART OF KIT 731457)
9	731442	1	QUICK DISCONNECT, NIPPLE
10	731443	1	QUICK DISCONNECT PLUG, 6MPT (PART OF KIT 731457)
11	731444	1	TRIGGER GUN (PART OF KIT 731457)
12	731445	1	INSULATED LANCE (PART OF KIT 731457)
13	731446	1	LANCE (PART OF KIT 731457)
14	731447	1	ADJUSTABLE TIP (PART OF KIT 731457)
15	REF.	-	SOLUTION TANK

OPTION - PRESSURE WASHER HYDRAULIC HOSE GROUP (730041-3)

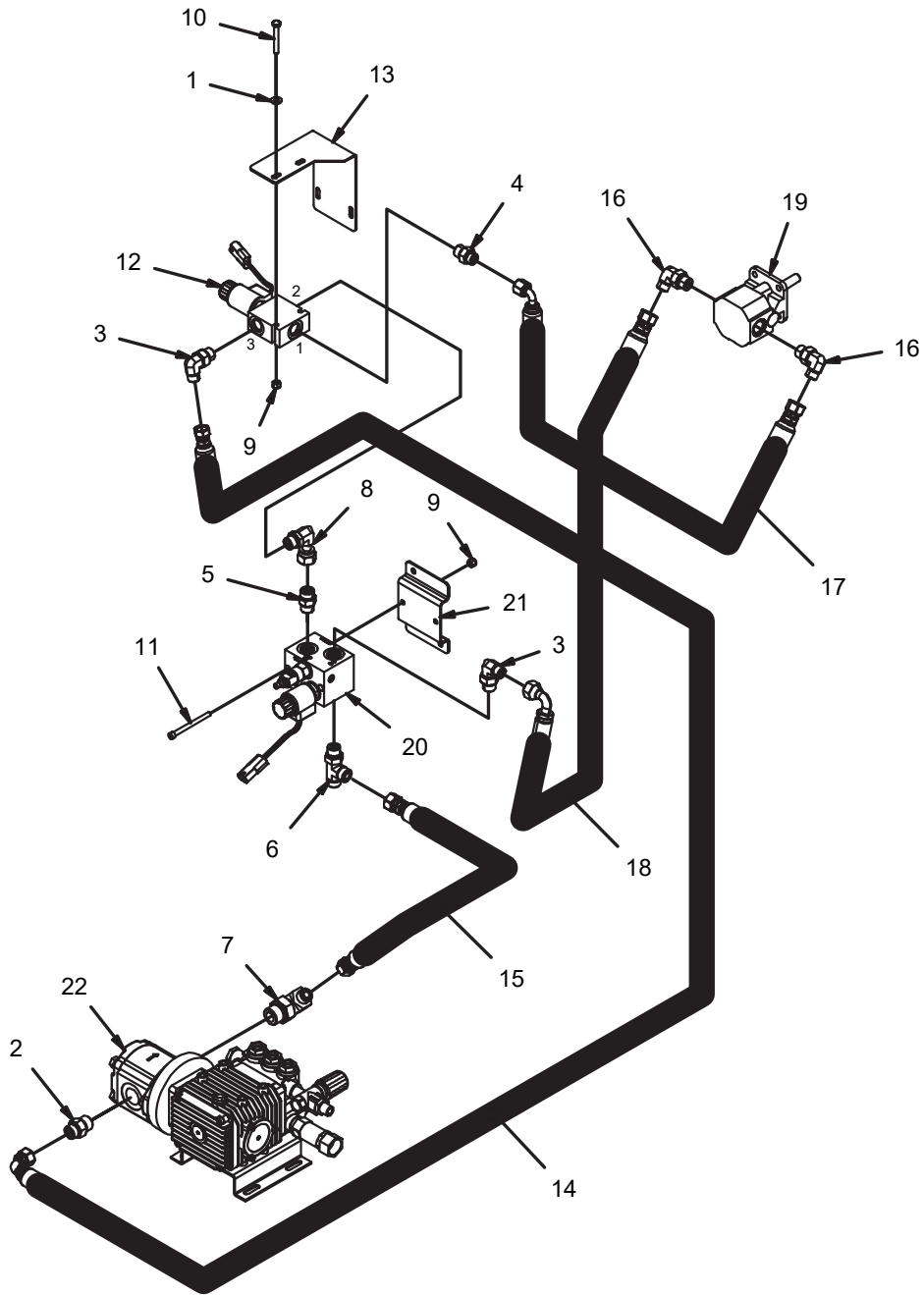

REV A

OPTION - PRESSURE WASHER HYDRAULIC HOSE GROUP (730041-3))

Parts List 730041-3			
ITEM	PART NUMBER	QTY	DESCRIPTION
1	3400089	2	WASHER, 1/4 .625 X .281 X .063
2	3400689	1	FTG, STR THD CONNECTOR -8 ORFS TO -10 SAE
3	675520	1	FITTING, ELBOW, 6 ORFS - 8 O-RING
4	675521	1	FITTING, STR, -6 ORFS - 8 SAE
5	675524	1	FITTING, STR, -8 ORFS - 8 SAE
6	675525	1	FITTING, RUN TEE, -8 ORFS - 8 ORFS - 8 SAE
7	675537	1	FITTING, 90, -8 ORFS - 12 SAE
8	675628	1	FTG - STR THD SWIVEL ELBOW, -8 ORFS TO -8 SAE
9	711373	4	NUT, FIBER INSERT 1/4-20
10	712567	2	SCREW, 1/4-20 X 2.00 HH SS
11	730965	2	BOLT, 1/4-20 X 3.00 SOC HD CAP
12	731292	1	ASSEMBLY, SOLENOID VALVE 2-POS 3-WAY
13	731431	1	BRACKET, SOLENOID MNT
14	731452	1	HOSE, 6 STR - 8 90 (SOL 3 TO PW PUMP IN)
15	731453	1	HOSE, 8 STR - 8 STR (PW PUMP OUT TO IMP SOL T)
16	REF.	-	FITTING, -6ORFS TO -8 SAE
17	REF.	-	HOSE 731061-1 (IMP LEFT TO SOL 1)
18	REF.	-	HOSE 731062-1 (IMP RIGHT TO IMP SOL VF IN)
19	REF.	-	IMPELLER MOTOR
20	REF.	-	IMPELLER MANIFOLD
21	REF.	-	MANIFOLD BRACKET
22	REF.	-	PRESSURE WASHER PUMP

OPTION - LOW LP INDICATOR GROUP (730042)

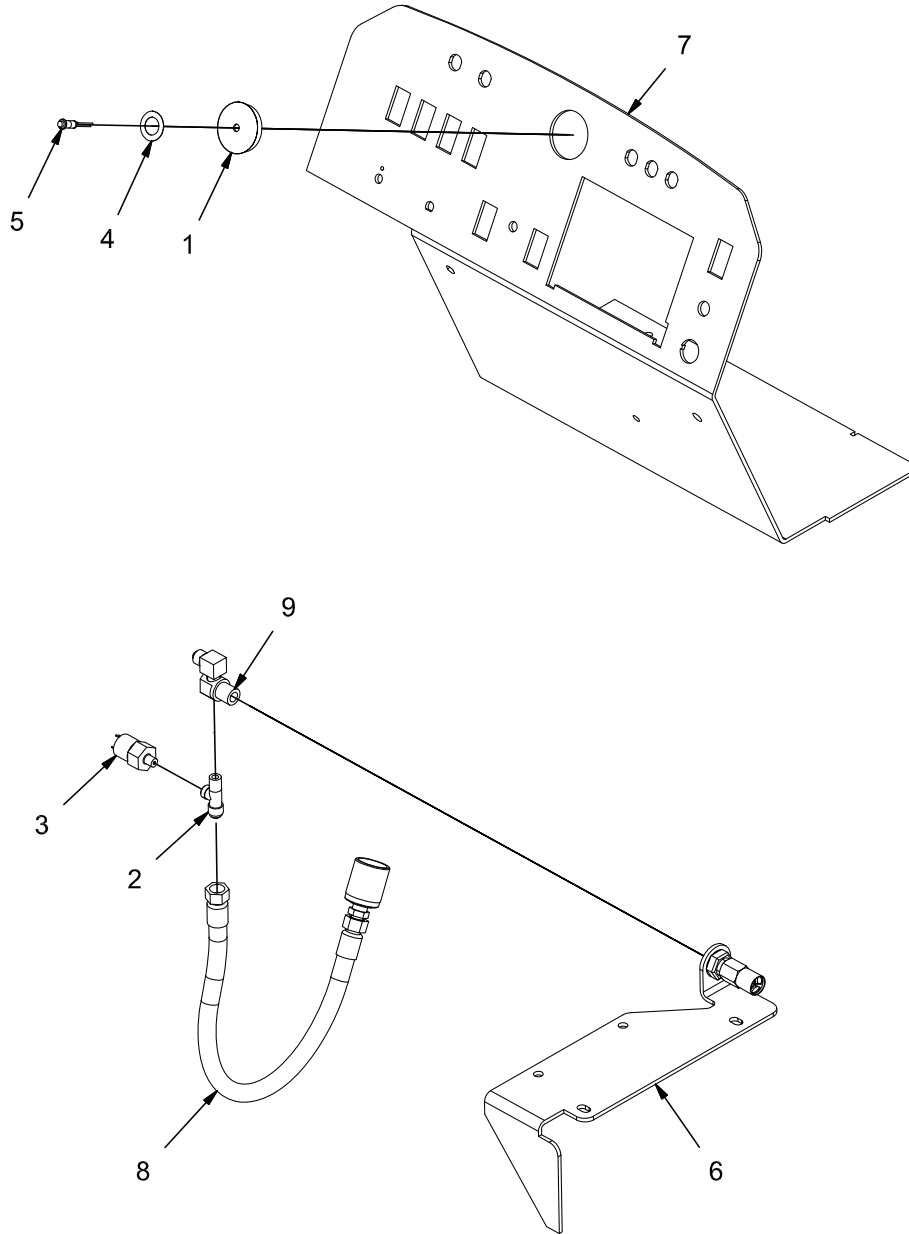

REV *

OPTION - LOW LP INDICATOR GROUP (730042)

Parts List 730042			
ITEM	PART NUMBER	QTY	DESCRIPTION
1	3301822-1	1	PLUG, PLASTIC, W/ MOUTING HOLE
2	3305535-2	1	TEE, BRASS
3	3305535-3	1	LP INDICATOR SENSOR
4	3305535-4	1	LPG LABEL
5	748960	1	ASSY, INDICATOR LAMP, LO LP
6	REF.	-	FRAME WITH PRESSURE RELIEF VALVE
7	REF.	-	INSTRUMENT PANEL
8	REF.	-	LP TANK HOSE
9	REF.	-	RELIEF VALVE MOUNT
-	748770	1	WIRE ASSY, LOW LP INDICATOR

OPTION - REAR SQUEEGEE GUARD (730048)

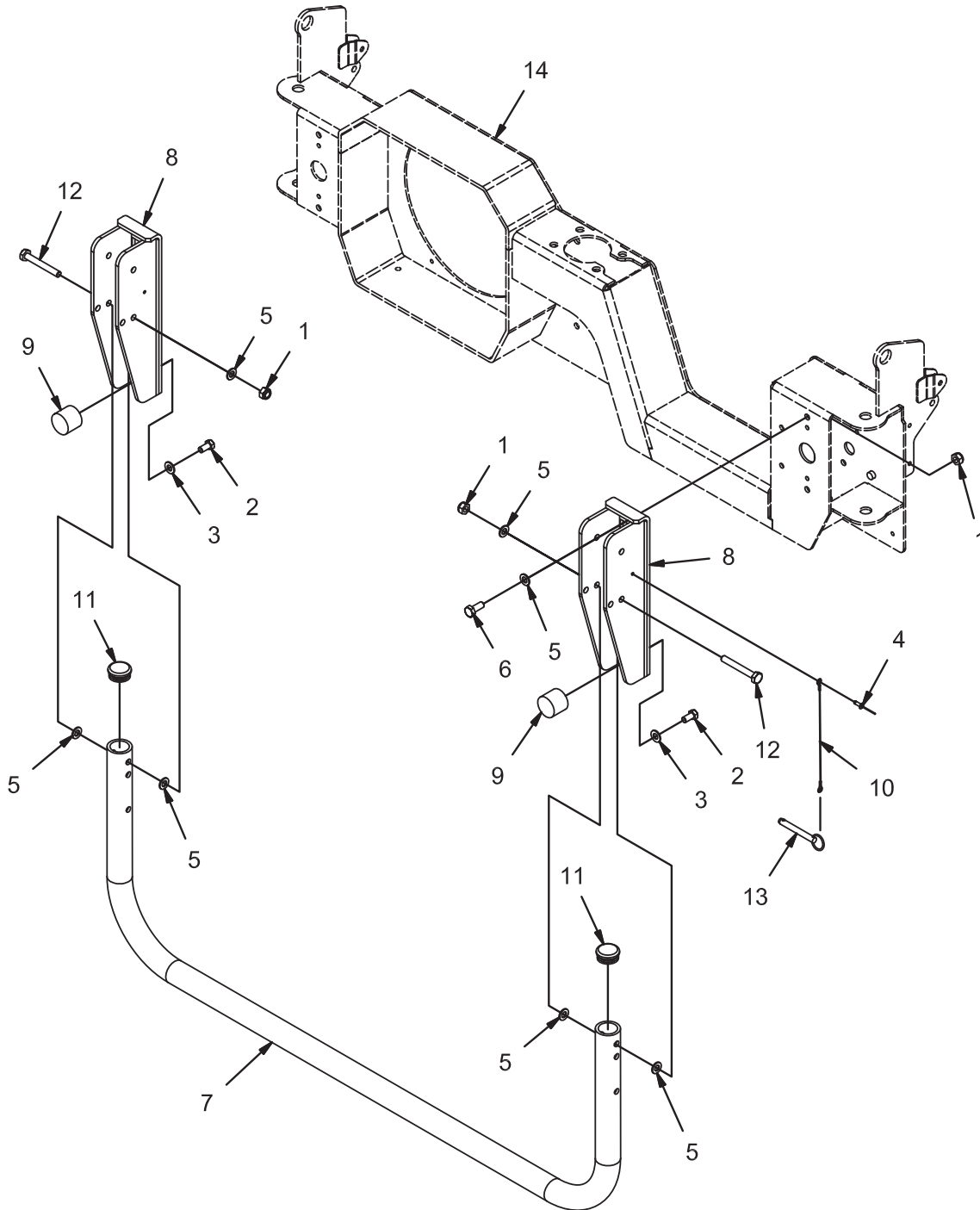

REV *

OPTION - REAR SQUEEGEE GUARD (730048)

Parts List 730048			
ITEM	PART NUMBER	QTY	DESCRIPTION
1	12040069	6	NUT, M10-1.50 ESN
2	3400335	2	SCREW, 3/8-16 X .750 HH SS
3	3400385	2	WASHER, 3/8, BELLEVILLE
4	3400484	1	RIVET, MULTI-GRIP
5	730344	10	WASHER, M10 SS
6	730958	4	BOLT, M10-1.50 X 25 HH SS
7	731488	1	TUBE, GUARD
8	731491	2	WELDMENT, GUARD MOUNT
9	731492	2	BUMPER, URETHANE
10	731501	1	LANYARD
11	731502	2	PLUG, HOLE, 1.25
12	731462	2	SCR-HH, M10-1.50 X 75 HH P CLASS 8.8
13	731493	1	PIN, CLEVIS, .375, BALL DETENT
14	REF.	-	FRAME

OPTION - RESERVE LPG TANK GROUP (730160)

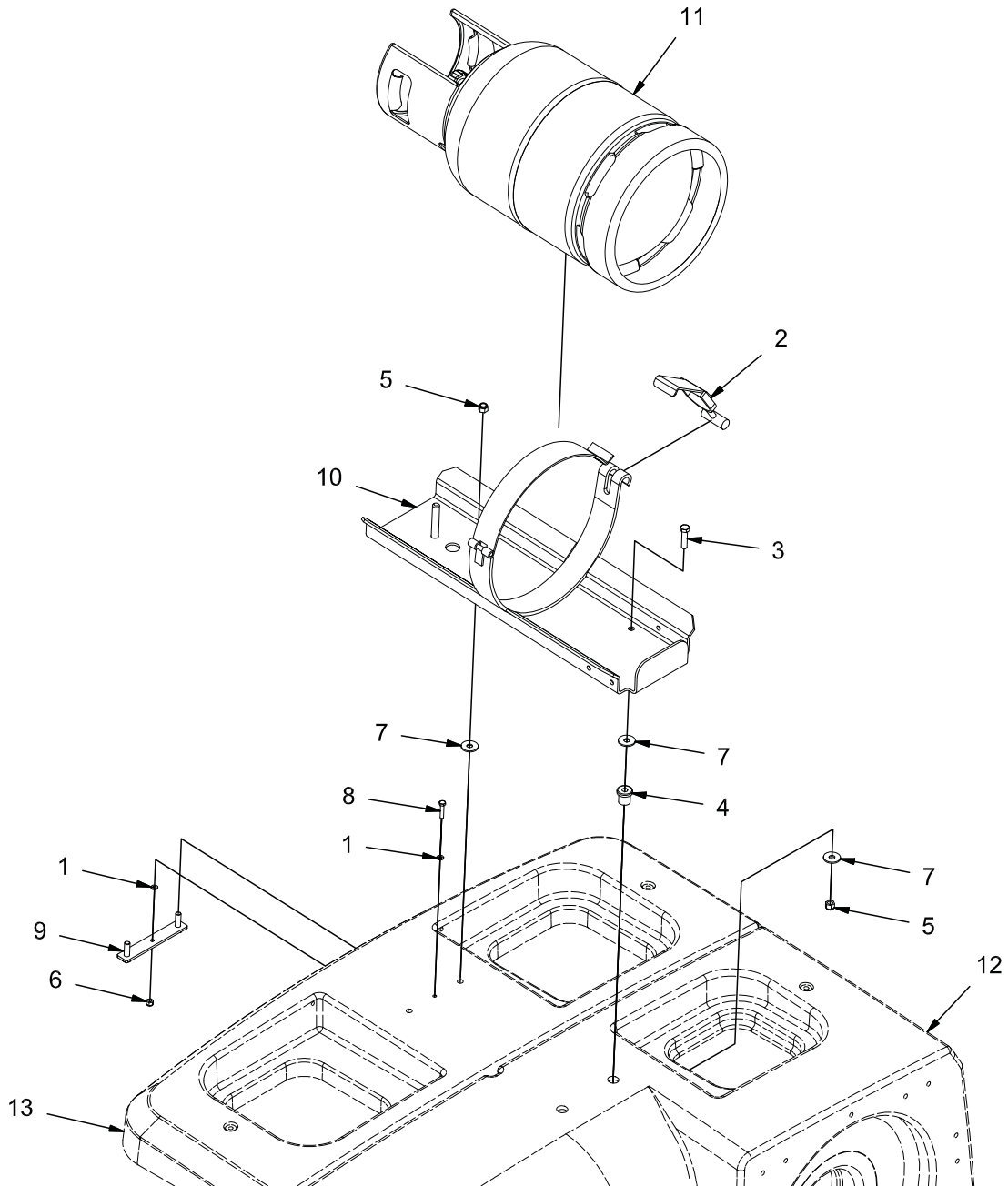

REV *

OPTION - RESERVE LPG TANK GROUP (730160)

Parts List 730160			
ITEM	PART NUMBER	QTY	DESCRIPTION
1	12310256	2	WASHER, M6, SS
2	220131	1	BUCKLE
3	3400455	2	SCREW, 3/8-16 X 1.50 HH SS
4	3300465	2	ISOLATOR, VIB
5	3400340	4	NUT, 3/8-16 ESN SS
6	600933	1	NUT, M6-1.00 ESN SS
7	717040	6	WASHER, FENDER, .413 B 1.18 OD .098 T SS
8	731050	1	BOLT, M6-100 X 30 HH SS
9	730993	1	WELDMENT, BOLT PLT
10	731010	1	WELDMENT, LPG RACK
11	REF.	-	LPG TANK
12	REF.	-	SOLUTION TANK
13	REF.	-	DEMISTER

OPTION - STROBE LIGHT GROUP W/CHEMICAL METERING (730166)

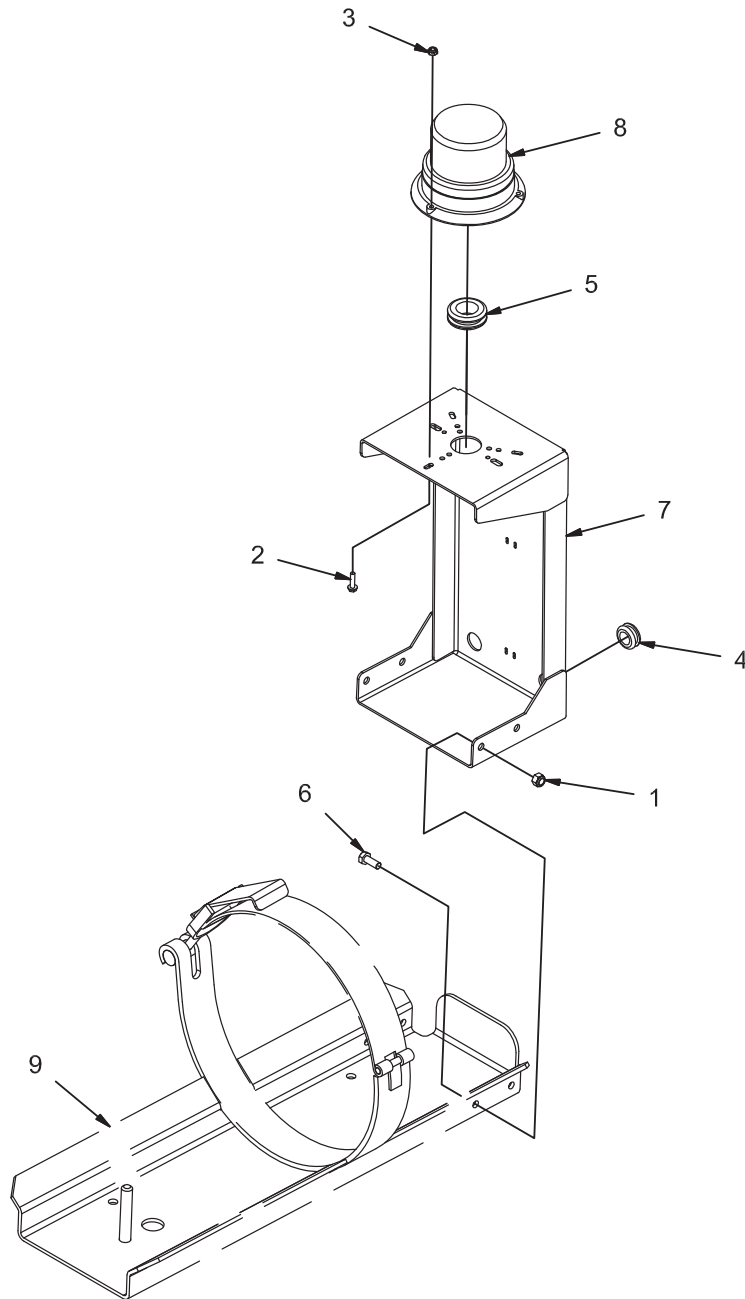

REV *

OPTION - STROBE LIGHT GROUP W/CHEMICAL METERING (730166)

Parts List 730166			
ITEM	PART NUMBER	QTY	DESCRIPTION
1	12040051	4	NUT, M8-1.25 ESN
2	3400044	3	SCR-HEX,#10-32 X 0.75 ZP
3	3400172	3	NUT, 10-32 ESN
4	600151	1	GROMMET, .63 ID .88 OD .25 T
5	620160	1	GROMMET, 1.00 ID .1.375 OD .25 T
6	717024	4	BOLT, M8-1.25 X 20 HH
7	731115-1	1	WELDMENT, SAFETY LIGHT MNT
8	748918	1	ASSEMBLY, AMBER STROBE LIGHT
9	REF.	-	RESERVE LPG RACK

OPTION - ROTATING LIGHT GROUP W/CHEMICAL METERING (730167)

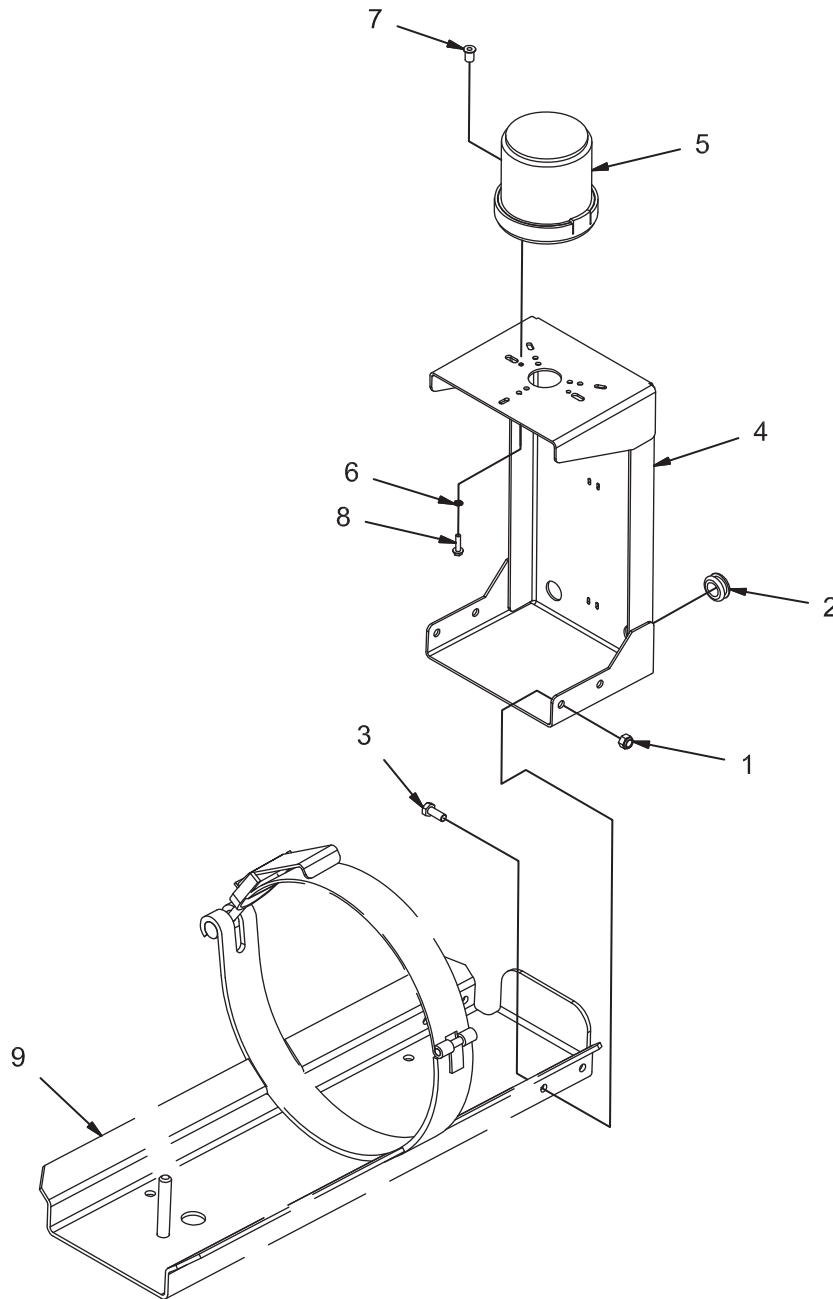

REV *

OPTION - ROTATING LIGHT GROUP W/CHEMICAL METERING (730167)

Parts List 730166			
ITEM	PART NUMBER	QTY	DESCRIPTION
1	12040051	4	NUT, M8-1.25 ESN
2	600151	1	GROMMET, .63 ID .88 OD .25 T
3	717024	4	BOLT, M8-1.25 X 20 HH
4	731115-1	1	WELDMENT, SAFETY LIGHT MNT
5	748920	1	ASSEMBLY, AMBER FLASHING LIGHT
6	PART OF 748919	2	STAR WASHER
7	PART OF 748919	2	NUT, EXPANSION
8	PART OF 748919	2	SCREW
9	REF.	-	RESERVE LPG RACK

OPTION - FLASHING LIGHT GROUP W/CHEMICAL METERING (730168)

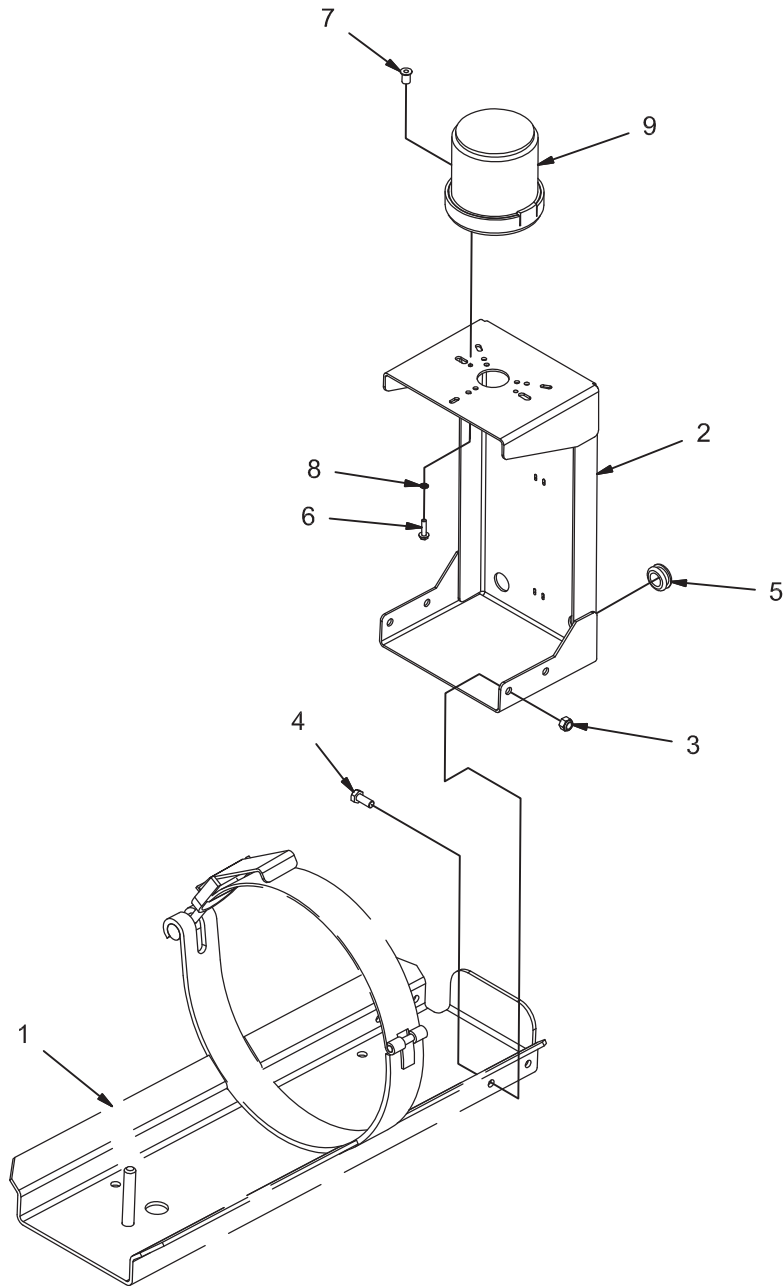

REV *

OPTION - FLASHING LIGHT GROUP W/CHEMICAL METERING (730168)

Parts List 730168			
ITEM	PART NUMBER	QTY	DESCRIPTION
1	REF.	-	RESERVE LPG RACK
2	731115-1	1	WELDMENT, SAFETY LIGHT MNT
3	12040051	4	NUT, M8-1.25 ESN
4	717024	4	BOLT, M8-1.25 X 20 HH
5	600151	1	GROMMET, .63 ID .88 OD .25 T
6	PART OF 748920	2	SCREW
7	PART OF 748920	2	NUT, EXPANSION
8	PART OF 748920	2	STAR WASHER
9	748920	1	ASSEMBLY, AMBER FLASHING LIGHT

OPTION - BACKUP ALARM GROUP - CM, RESERVE LPG IN (730169)

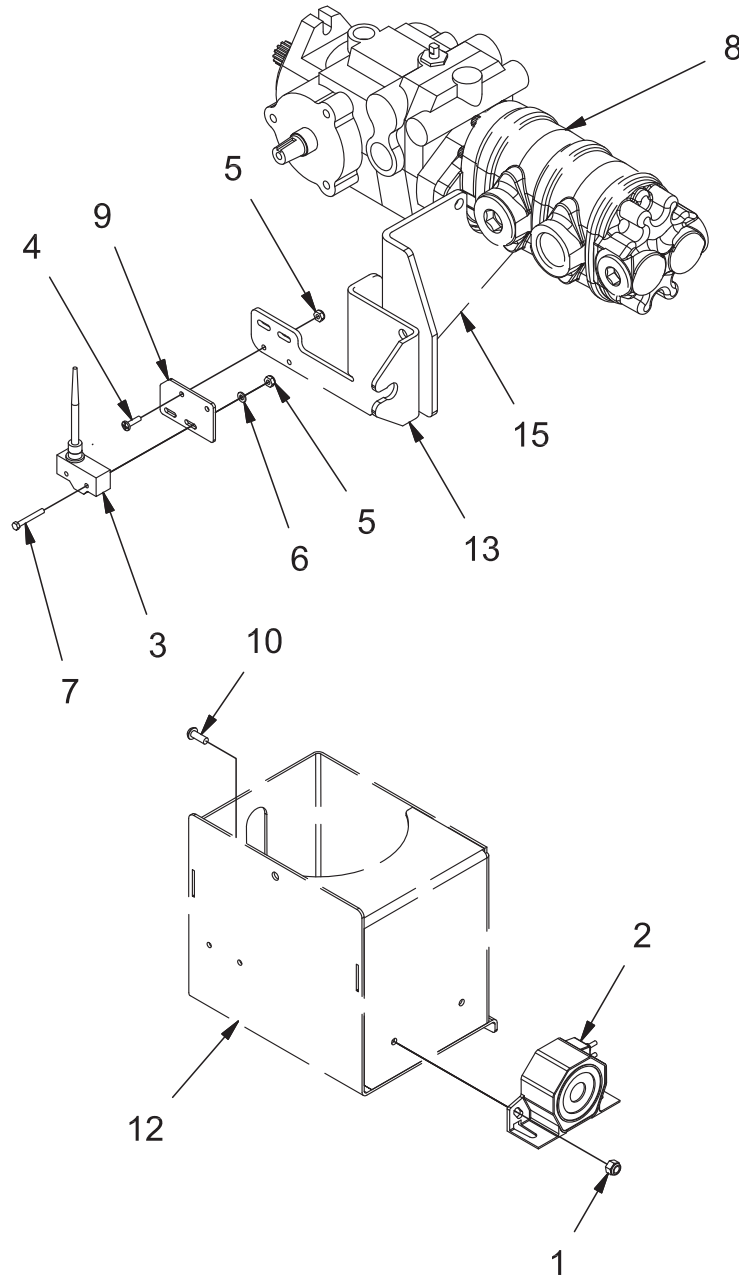

REV A

OPTION - BACKUP ALARM GROUP - CM, RESERVE LPG IN (730169)

Parts List 730169			
ITEM	PART NUMBER	QTY	DESCRIPTION
1	12040044	2	NUT, M6-1.00 ESN
2	3303002	1	ALARM, BACKUP
3	3342546-1	1	HARNESS, SWITCH, WHISKER
4	3400045	2	SCREW, #8-32 X .625 PAN HD ZP
5	3400082	4	NUT, FIBER INSERT #8-32
6	3400096	2	FLATWASHER, #8
7	620136	2	BOLT, #8-32 X 1.25 HH ZP
8	730310	1	PUMP, AUX
9	731002	1	MOUNT, REVERSE SWITCH
10	731116	2	SCREW, M6-1.00 X 16 BUTTON HD CAP ZP
11	748980	1	HARNESS, SAFETY LT & BACKUP ALARM
12	REF.	-	CHEMICAL PUMP MNT
13	REF.	-	ADJUSTER, HYDROBACK W/SW MNT
14	REF.	-	PUMP ASSEMBLY
15	REF.	-	HYDROBACK MOUNT

OPTION - DUST SUPPRESSION (731482)

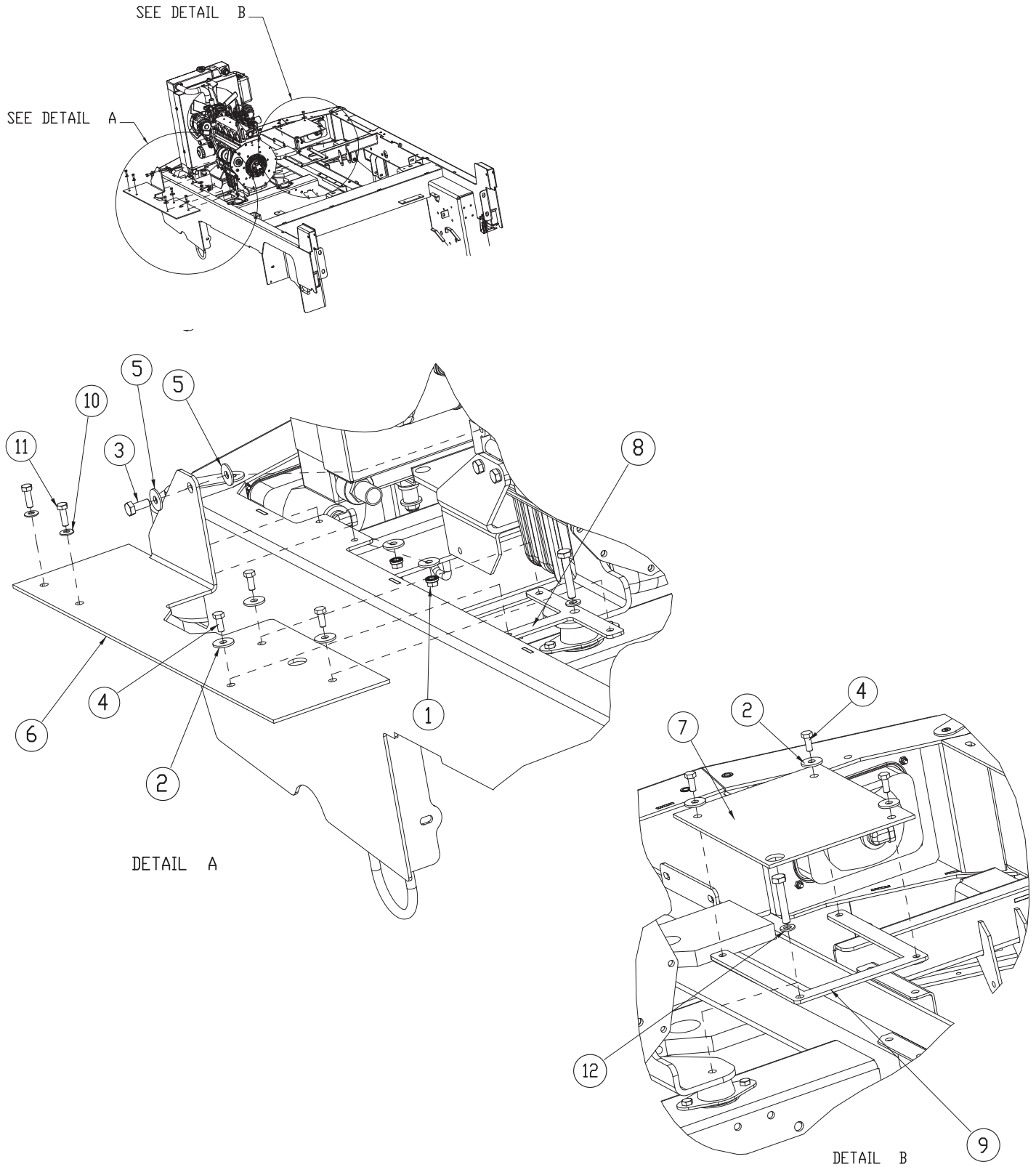

PARTS LIST - 731482			
ITEM	PART NO.	QTY	DESCRIPTION
1	600934	2	NUT-FLANGE WIZZ M8-1.25 ZP
2	600940	8	WASHER-FENDER M8 X 24 ZP
3	620082	1	SCR-HH M10-1.25 X 25 ZP CLASS 8.8
4	717024	6	SCR-HH M8-1.25 X 20 ZP GRADE 8.8
5	717040	2	WASHER-FLAT M10.5 X 30 X 2.5 SS
6	731474	1	FLAP, DUST SUPPRESSION, LH
7	731475	1	FLAP, DUST SUPPRESSION , RH
8	731477	1	MOUNT, DUST SUPPRESSION, LH
9	731480	1	MOUNT, DUST SUPPRESSION, RH
10	3400384	2	WASHER-CONICAL SPRING 5/16
11	11038247	2	SCR-HH M8-1.25 X 25 ZP CLASS 8.8
12	12310058	2	WASHER-FLAT M10.5 X 20 X 2 ZP

MISCELLANEOUS ADDITIONAL OPTIONS

730019	OPT - SOFTSIDE CAB
730044	OPT - SIPED TIRES
730045	OPT - PARKING BRAKE
730046	OPT - LH SIDE MIRROR
731467	OPT - NOISE REDUCTION
730123-HF	OPT - HIGH FLOW SOLUTION CONTROL

THIS PAGE INTENTIONALLY LEFT BLANK

LAYOUTS - ELECTRICAL/HYDRAULIC

ELECTRICAL SCHEMATIC LAYOUT

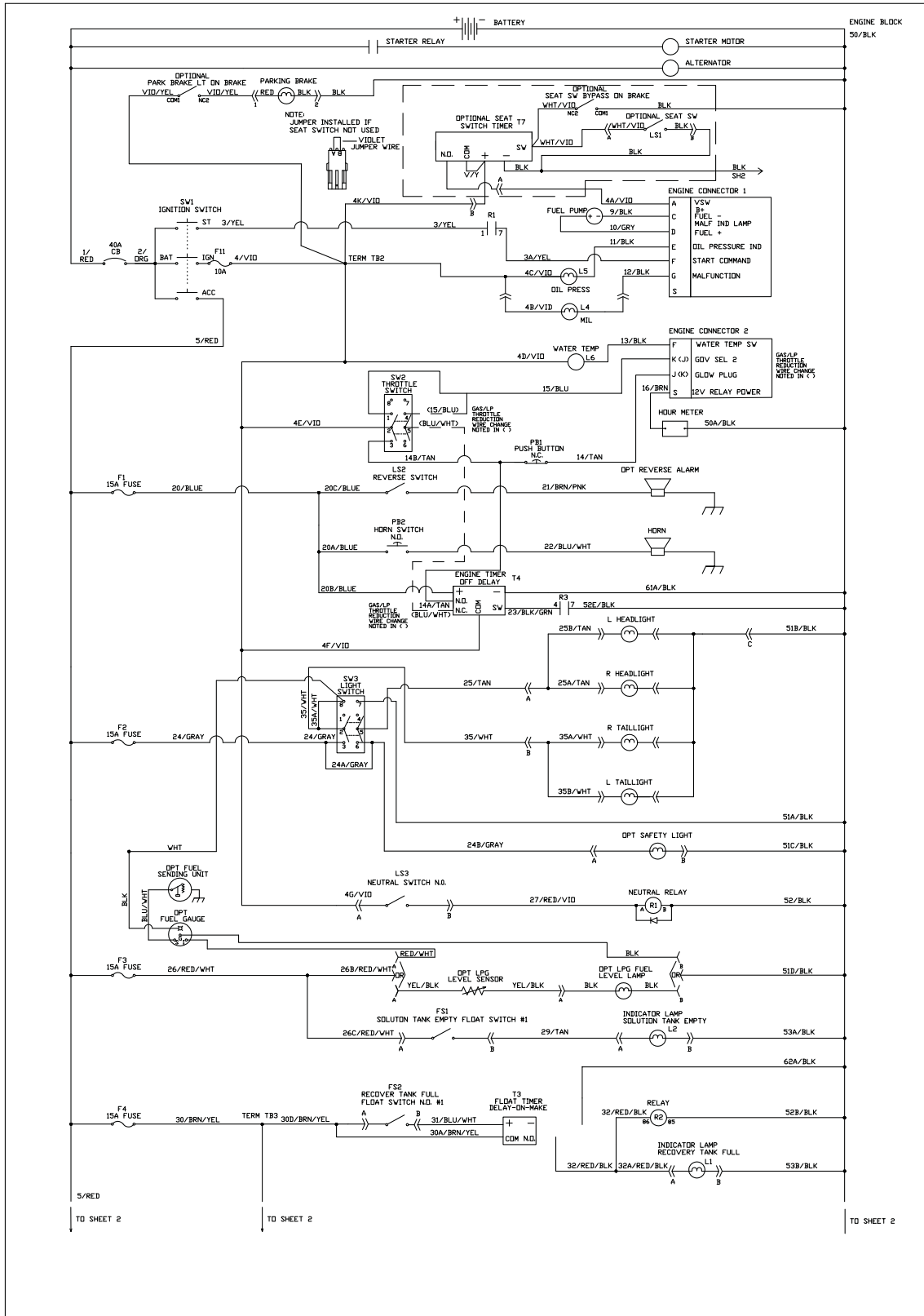

748992-1 REV B

ELECTRICAL SCHEMATIC LAYOUT

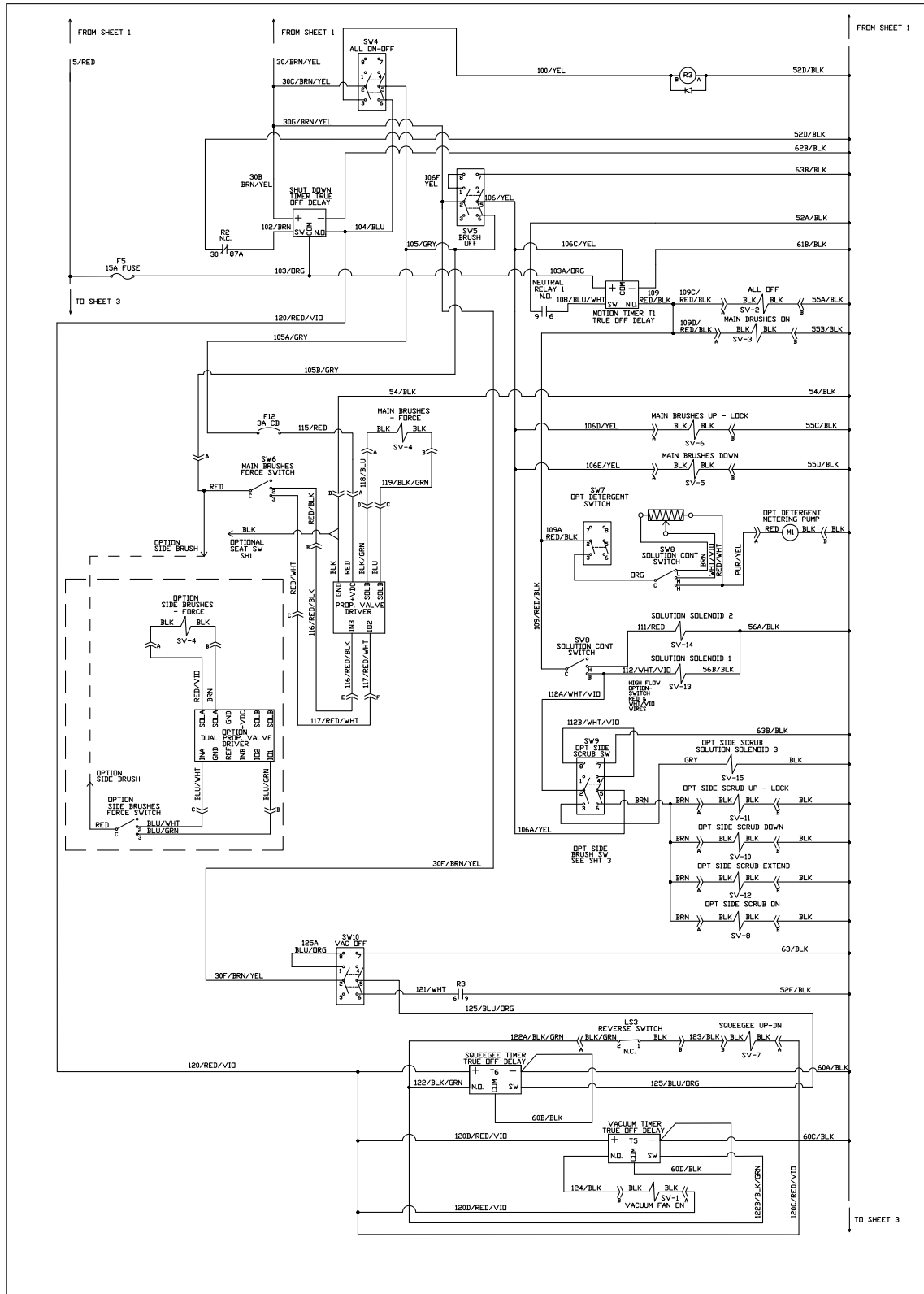

ELECTRICAL SCHEMATIC LAYOUT

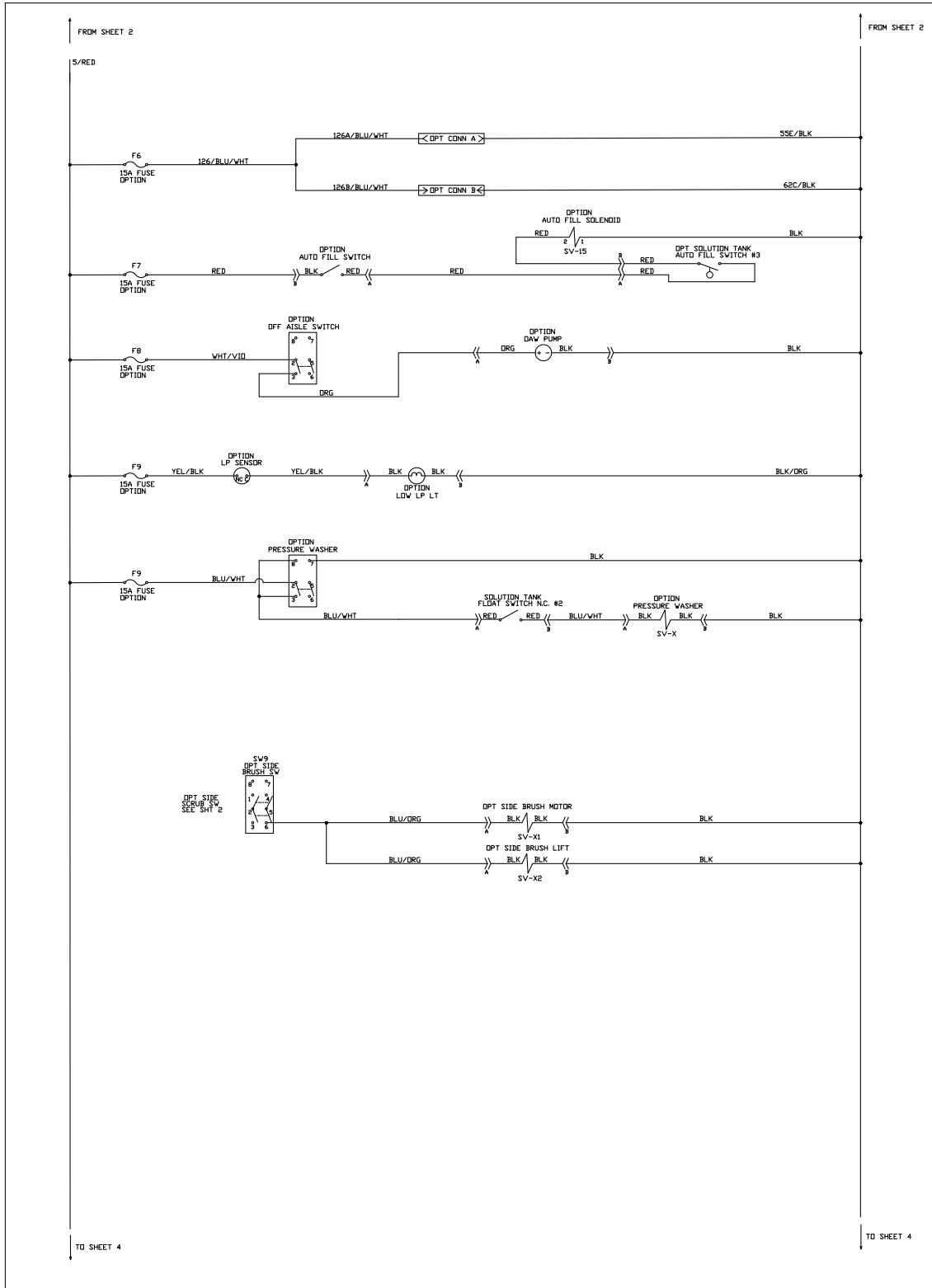

ELECTRICAL SCHEMATIC LAYOUT

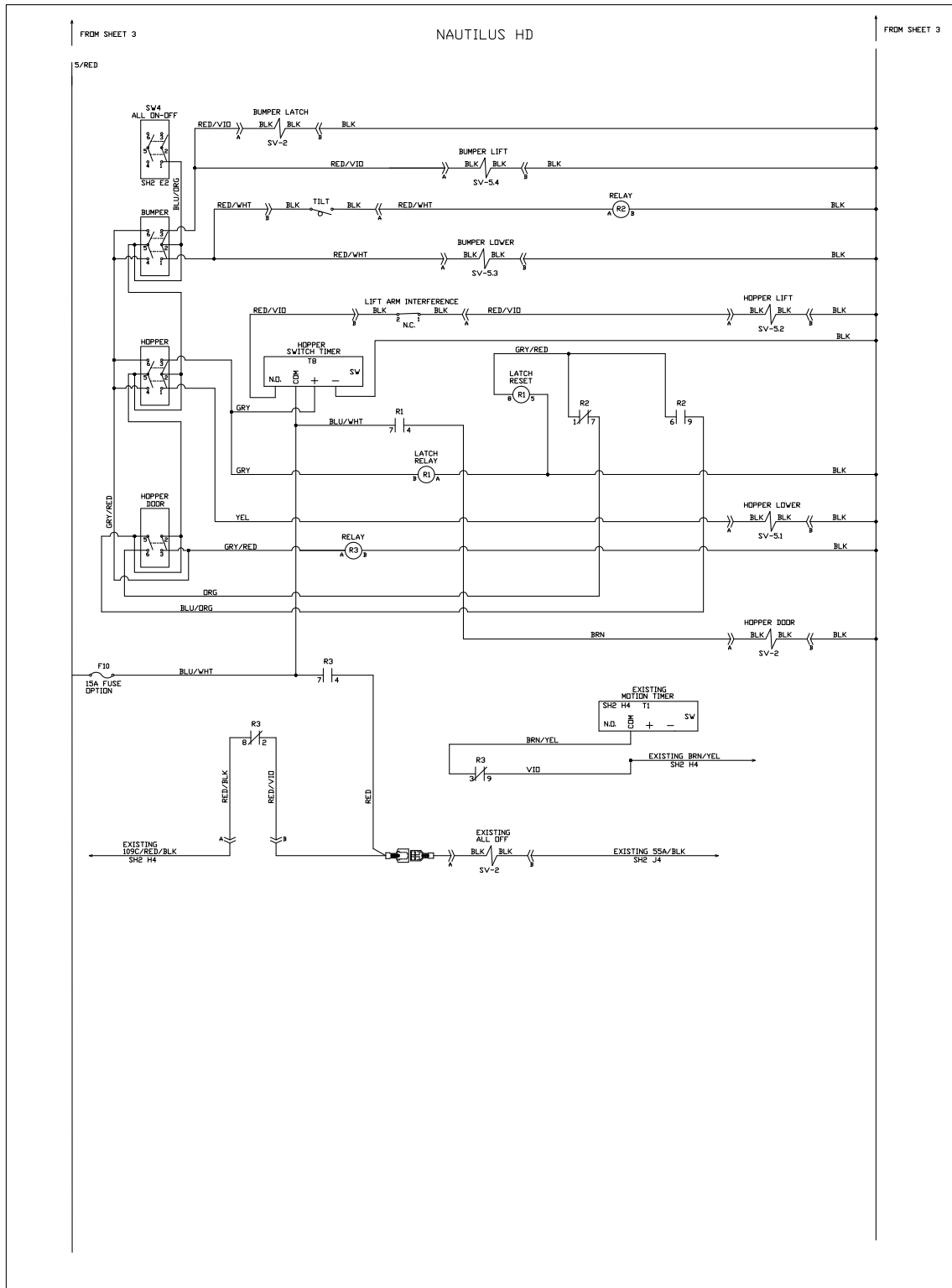

ELECTRICAL SCHEMATIC LAYOUT (POINT TO POINT WIRING)

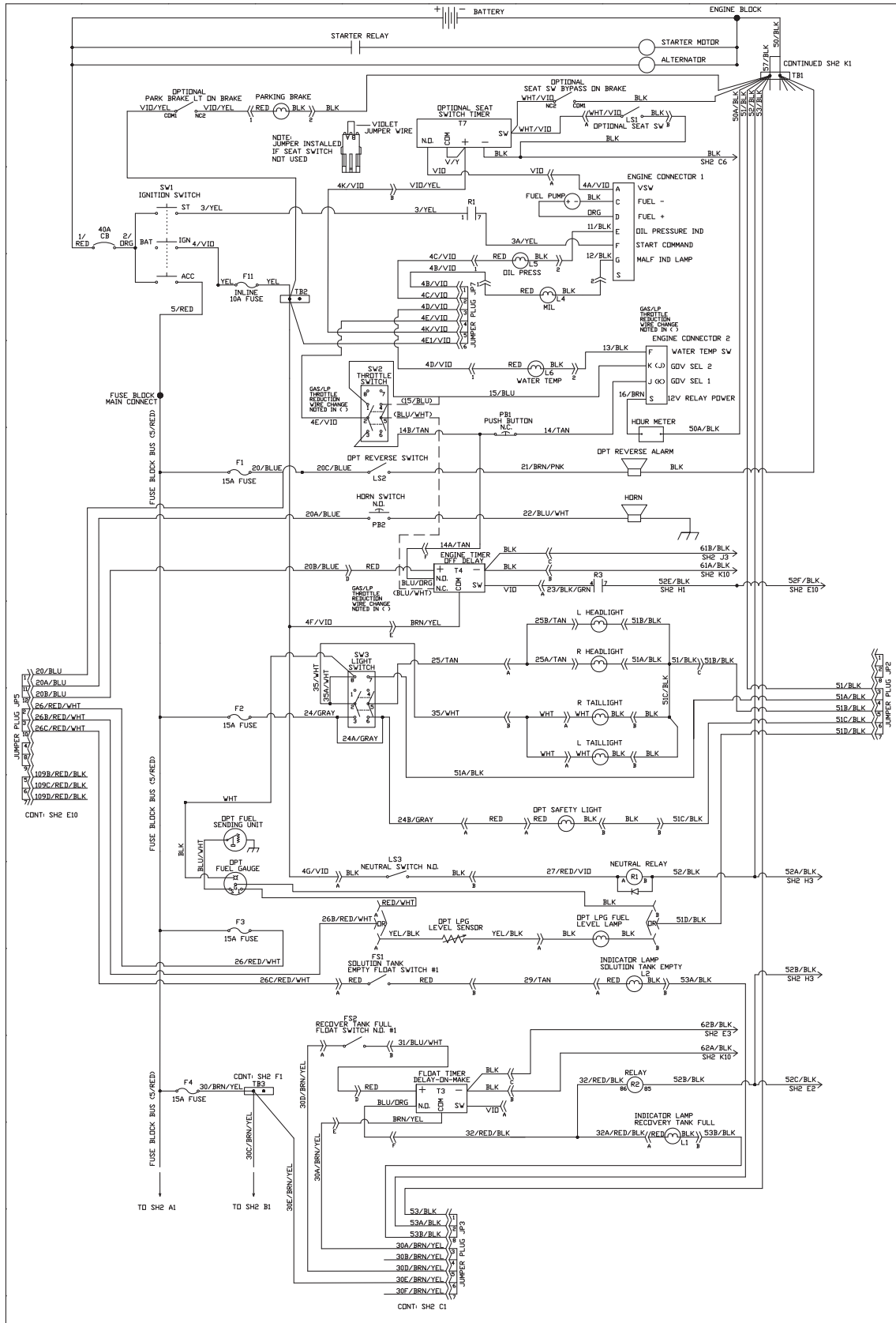

748992 REV E

ELECTRICAL SCHEMATIC LAYOUT (POINT TO POINT WIRING)

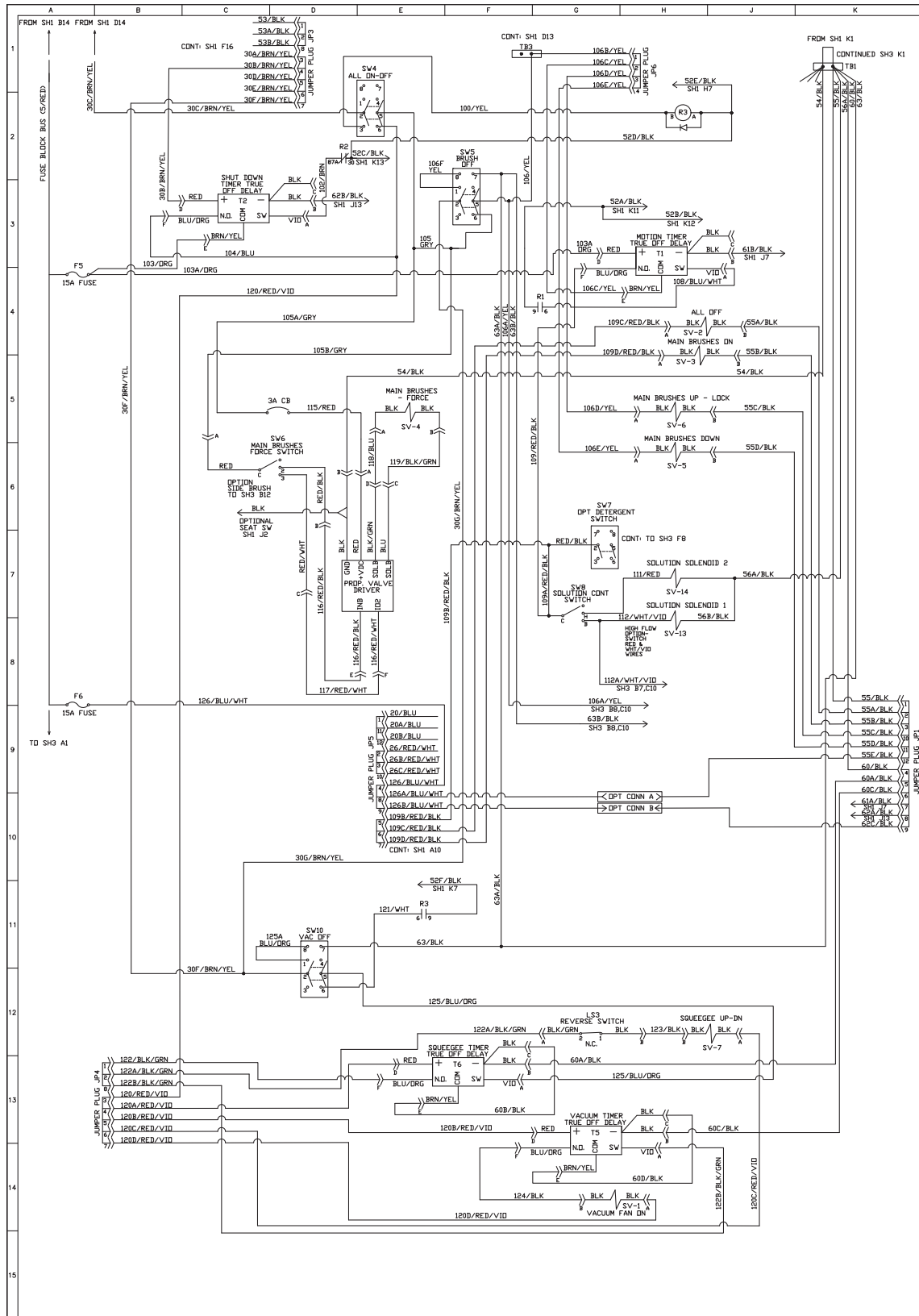

ELECTRICAL SCHEMATIC LAYOUT (POINT TO POINT WIRING)

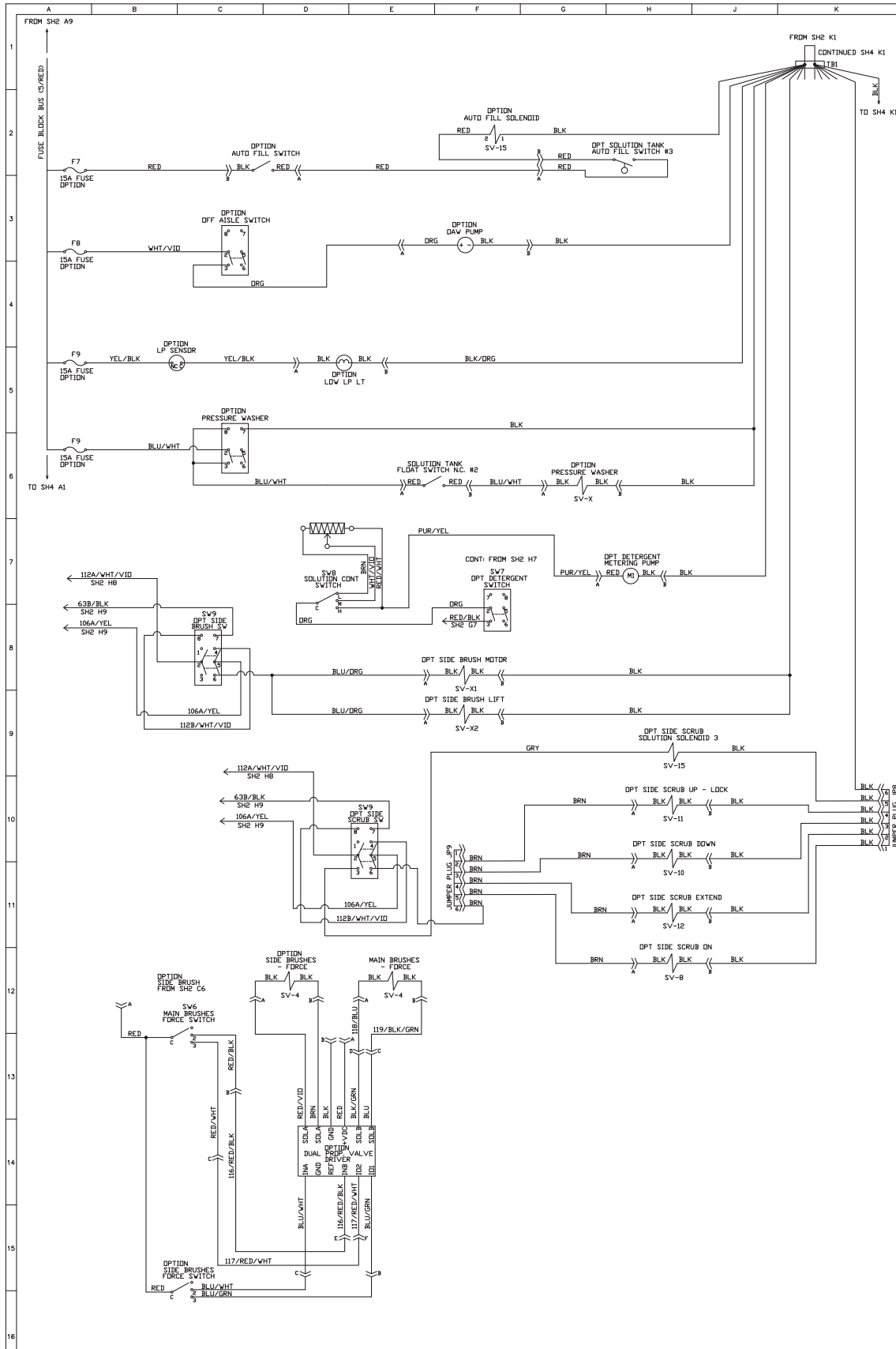

ELECTRICAL SCHEMATIC LAYOUT (POINT TO POINT WIRING)

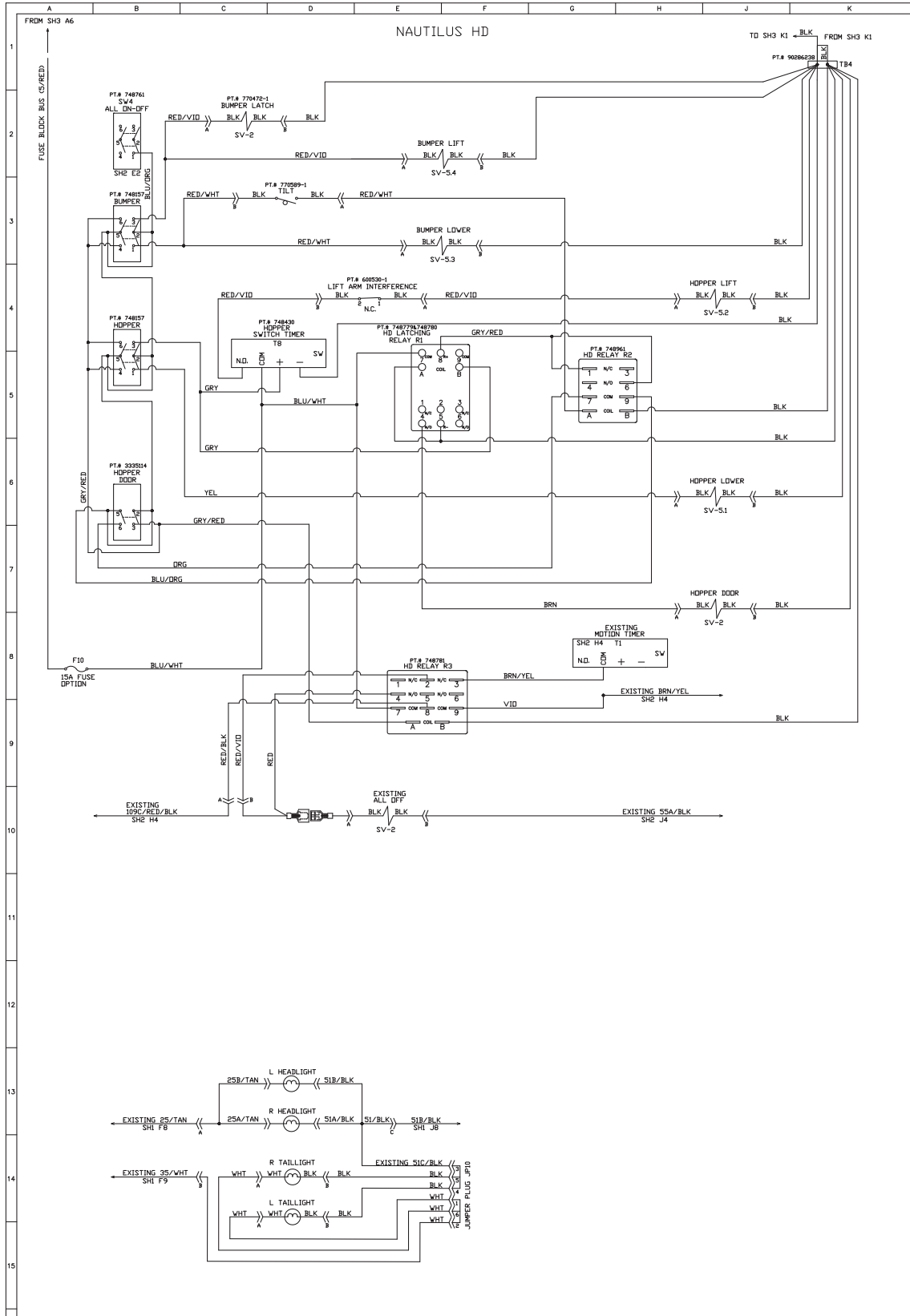

HYDRAULIC SYSTEM LAYOUT

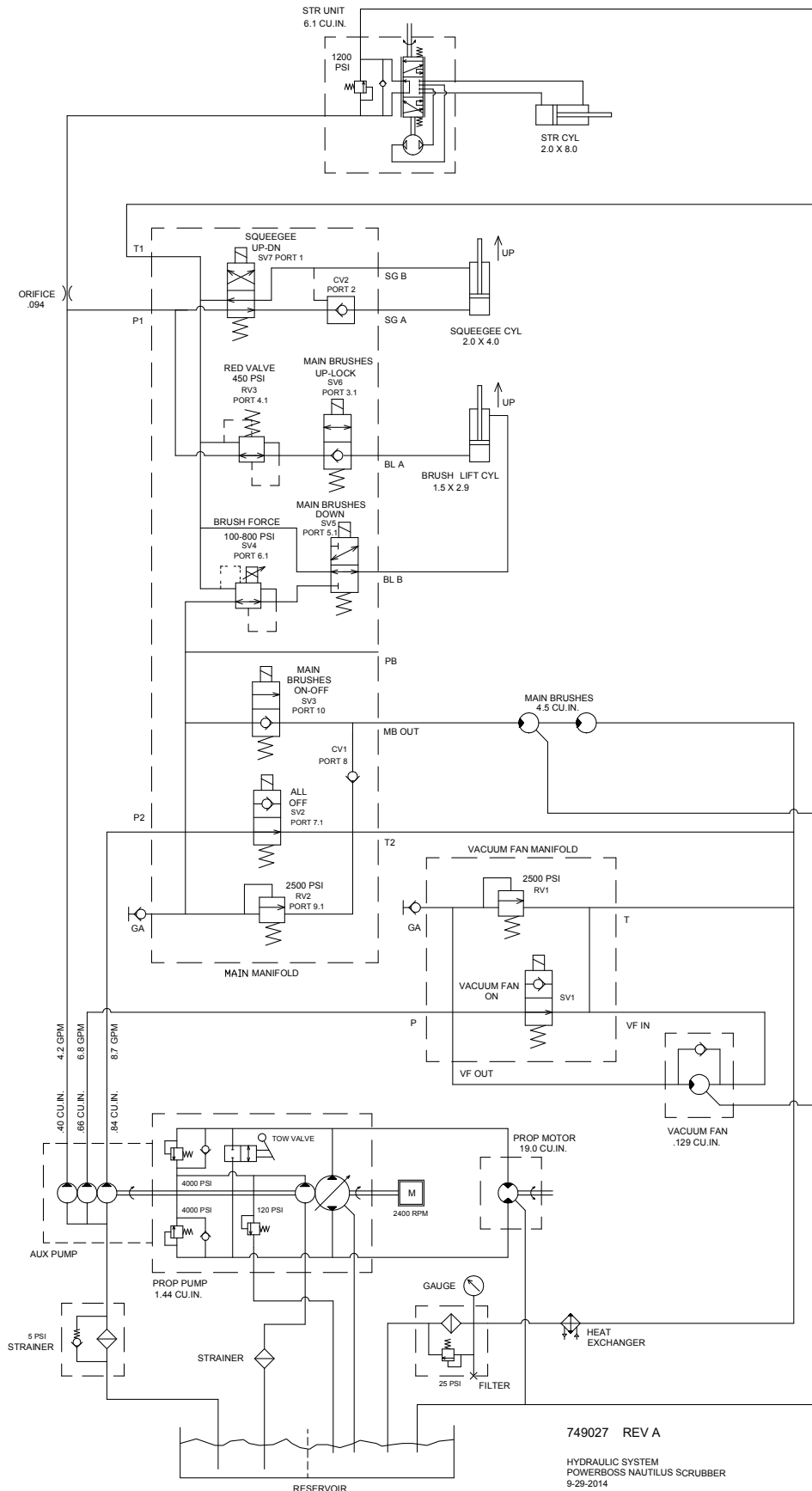

HYDRAULIC SYSTEM LAYOUT WITH OPTIONAL SIDE SCRUB BRUSH

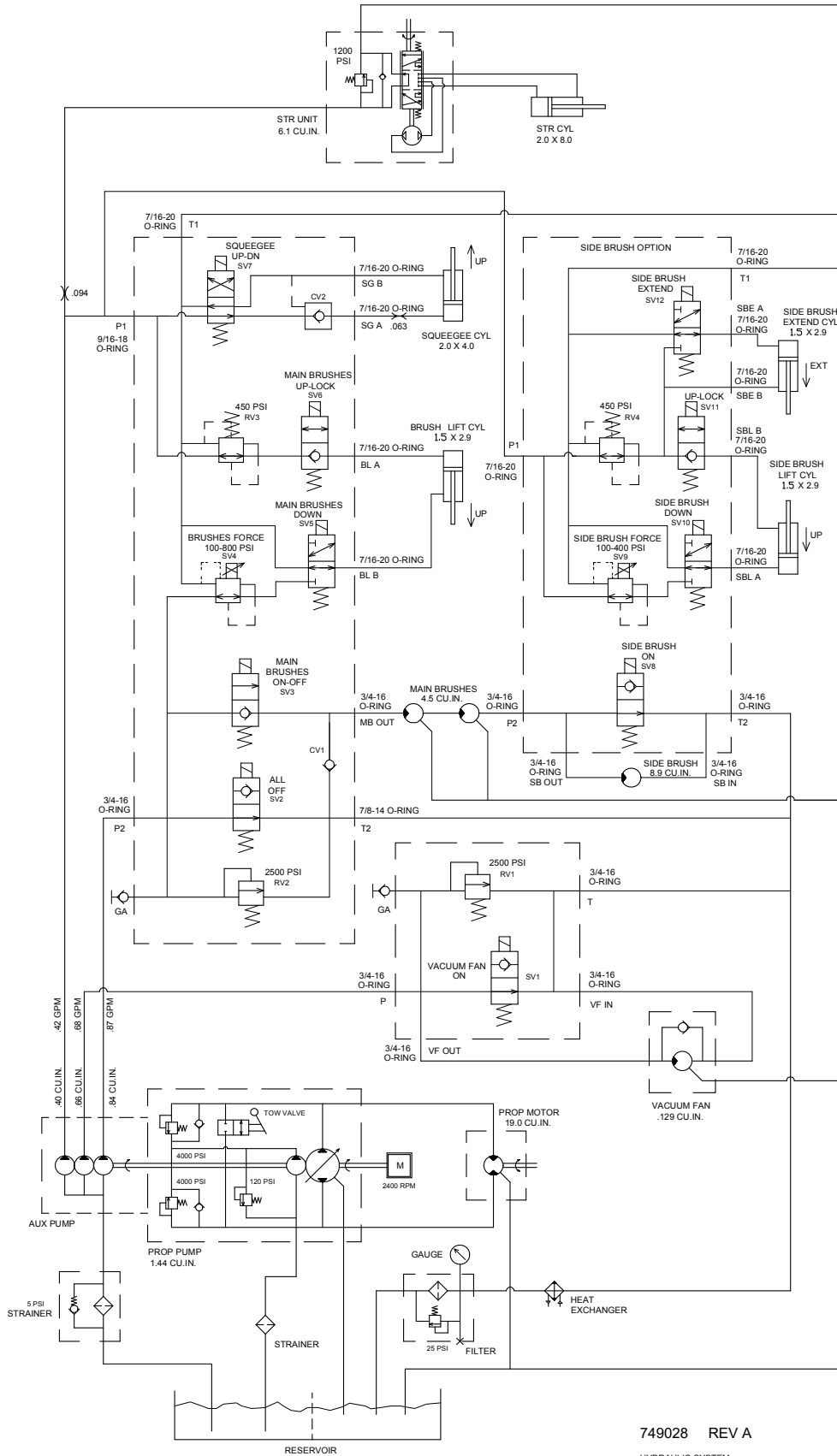

749028 REV A

HYDRAULIC SYSTEM
WITH OPTIONAL SIDE SCRUB BRUSH
POWERBOSS NAUTILUS SCRUBBER
5-22-2014

NOTES

WARRANTY

Revision J
Effective January 2014
PowerBoss Made Simple Industrial Limited Warranty

Minuteman International owner of PowerBoss warrants to the original purchaser/user that the product is free from defects in workmanship and materials under normal use. PowerBoss will, at its option, repair or replace without charge, parts that fail under normal use and service when operated and maintained in accordance with the applicable operation and instruction manuals. All warranty claims must be submitted through and approved by factory authorized repair stations.

This warranty does not apply to normal wear, or to items whose life is dependent on their use and care. Parts not manufactured by PowerBoss are covered by and subject to the warranties and/or guarantees of their manufacturers. Please contact Minuteman International for procedures in warranty claims against these manufacturers.

Special warning to purchaser -- Use of replacement parts not manufactured by PowerBoss or its designated licensees, will void all warranties expressed or implied. A potential health hazard exists without original equipment replacement.

All warranted items become the sole property of Minuteman International or PowerBoss or its original manufacturer, whichever the case may be.

PowerBoss disclaims any implied warranty, including the warranty of merchantability and the warranty of fitness for a particular purpose. PowerBoss assumes no responsibility for any special, incidental or consequential damages.

This limited warranty is applicable only in the U.S.A. and Canada, and is extended only to the original user/purchaser of this product. Customers outside the U.S.A. and Canada should contact their local distributor for export warranty policies. PowerBoss is not responsible for costs or repairs performed by persons other than those specifically authorized by PowerBoss. This warranty does not apply to damage from transportation, alterations by unauthorized persons, misuse or abuse of the equipment, use of non-compatible chemicals, or damage to property, or loss of income due to malfunctions of the product. If a difficulty develops with this machine, you should contact the dealer from whom it was purchased.

This warranty gives you specific legal rights, and you may have other rights, which vary from state to state. Some states do not allow the exclusion or limitation of special, incidental or consequential damages, or limitations on how long an implied warranty lasts, so the above exclusions and limitations may not apply to you.

	Travel *	Labor	Parts	Engine	Extended Warranty	Costs
Walk Behind						****
Battery Sweepers	90 Days	12 months	12 months	N/A	N/A	-
IC Sweepers	90 Days	12 months	12 months	Through Eng. Mfg.	N/A	-
Battery Scrubbers	90 Days	24 months	36 months	N/A	N/A	-
Riders						
Battery Scrubbers	90 Days	24 months	36 months or 2000 hr.	N/A	36 months parts + 24 labor (or 3000 Hours)	5%
IC Sweeper/Scrubbers 82 & 90	90 Days	6 months	24 months or 2000 hr.	24 months or 3000 hrs**	36 months parts + 24 months labor (or 3000 Hours) + 180 days travel	5%
I.C. Sweepers 9X, 10X	90 days	6 months	48 months or 3000 hrs.	60 months or 3000 hrs**	48 months parts + 24 months labor (or 3000 Hours) + 180 days travel	5%
NAUTILUS Scrubber	180 Days	24 months	36 months or 2000 hr.	36 months or 2000 hrs**	48 months parts + 24 months labor (or 3000 Hours) + 180 days travel	3%
All Rider, I.C. (excluding APEX series)					Bumper to Bumper 5000 hr max. 48 months parts, 48 months labor, 180 days travel	8%
Exceptions						
Apex Series Sweeper	90 Days	12 months	12 months or 1000 hr.	12 months or 1000 hrs**	24 months parts + 24 months labor (or 2000 Hours)	5%
6X Sweeper	90 Days	6 months	24 months or 2000 hr.	24 months or 2000 hours**	36 months parts + 24 months labor (or 3000 Hours) + 180 day travel	5%

- Tank Bladders** Eight years/ no additional labor
- Polyethylene plastic tanks** Ten years/ no additional labor
- Batteries** 0-3 months full replacement, 4-12 prorated credit
- Chargers** One-year replacement
- Aftermarket Replacement parts** Ninety days from date of purchase

***Two-Hour Cap Per Service Call**
****Through Engine Manufacturer. See Section 3 of Warranty Manual for Engine Warranty Exceptions**

***** Based Upon Dealer's Certification Status:**
Extended Warranty MUST Be Signed Up Within 30 Days of Delivery to End User
(Dealer Has 1Year From Receiving Machine To Sign Up For Extended Warranty)

****All above labor and travel reimbursed at 65% or 75% of the published shop rate.*



“The Power of Clean”

**PowerBoss® is a Full Line Manufacturer of Sweepers and Scrubbers,
for Industrial Facilities.**

PowerBoss®, Minuteman International, Inc. 14N845 U.S. Route 20 Pingree Grove, Illinois 60140
Phone: 800-323-9420 www.PowerBoss.com Email: tech@powerboss.com
A Member of the Hako Group

Nautilus Rider Scrubber/Sweeper #988749 Rev. D 01/16

PowerBoss® Copyright 2014-2015